

Lake Eastex Planning Studies *Final Report*

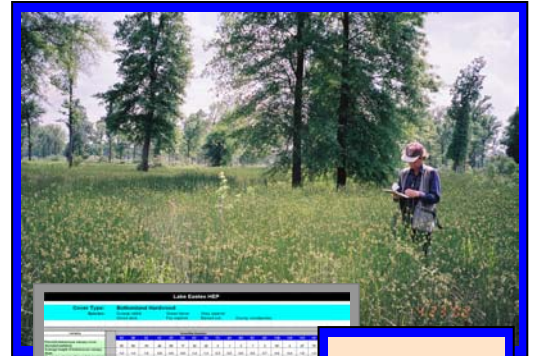

Station	Date	Time	Temp	Wind	Humidity	Pressure	Clouds	Visibility	Direction	Speed	Wave	Current	Water	Bottom	Depth	Salinity	Turbidity	Color	DO	pH	Conductivity	Chlorophyll	Phytoplankton	Zooplankton	Macroinvertebrates	Microinvertebrates	Microbes	Other
101	5/1/03	08:00	22.5	15	65	1013.2	10	10	SE	5	0.2	0.1	0.1	0.1	1.0	1000	10	20	8.5	7.2	150	0.5	0.5	0.5	0.5	0.5	0.5	0.5
102	5/1/03	09:00	23.0	15	65	1013.1	10	10	SE	5	0.2	0.1	0.1	0.1	1.0	1000	10	20	8.5	7.2	150	0.5	0.5	0.5	0.5	0.5	0.5	0.5
103	5/1/03	10:00	23.5	15	65	1013.0	10	10	SE	5	0.2	0.1	0.1	0.1	1.0	1000	10	20	8.5	7.2	150	0.5	0.5	0.5	0.5	0.5	0.5	0.5

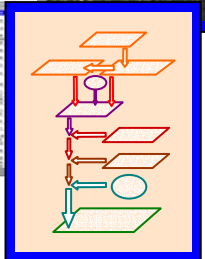

Prepared For:

Angelina and Neches River Authority
and
Texas Water Development Board

May 2003
ANR01289

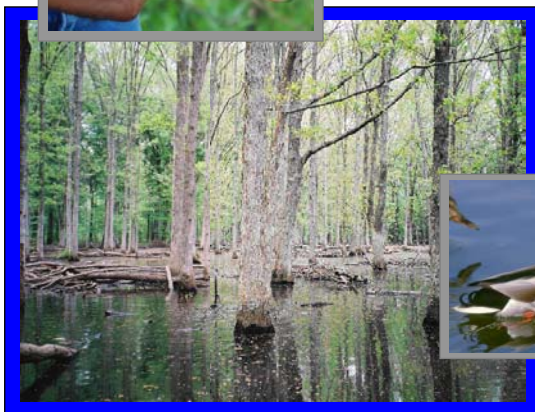
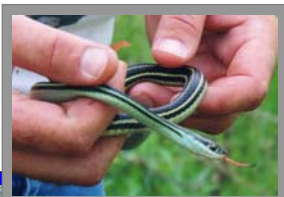
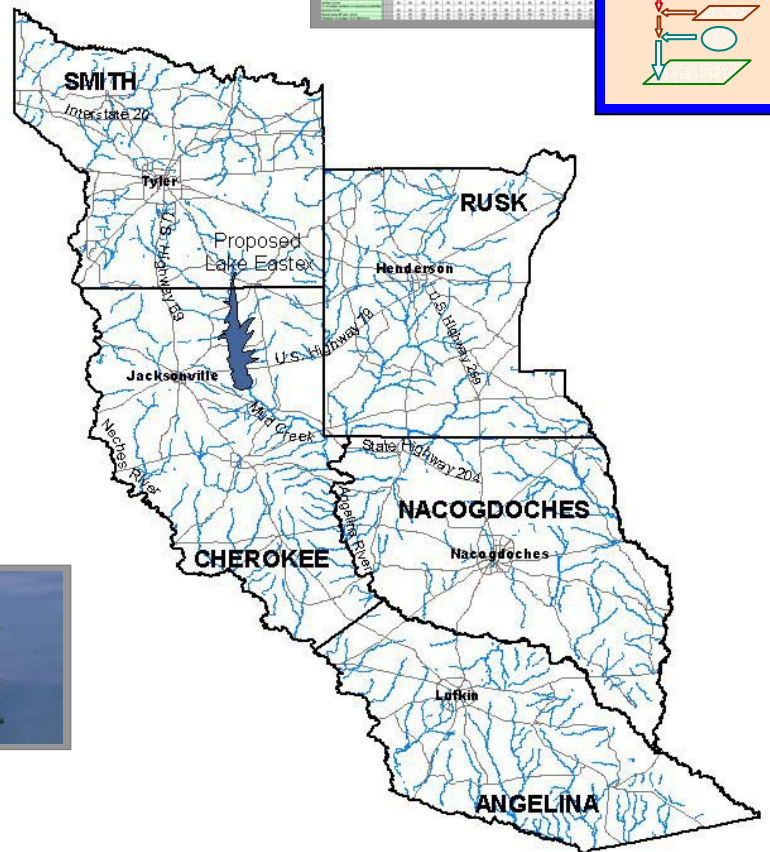

**ANGELINA AND NECHES RIVER AUTHORITY
LAKE EASTEX PLANNING STUDIES**

FINAL REPORT

MARCH 2003

PREPARED BY



ANR01289

**TABLE OF CONTENTS
VOLUME I**

- 1. INTRODUCTION**
- 2. INSTREAM FLOW EVALUATION**
- 3. RED-COCKADED WOODPECKER HABITAT STUDY**
- 4. ASSESSMENT OF WETLAND AND TERRESTRIAL HABITAT**
- 5. MITIGATION FOR POTENTIAL WILDLIFE, WETLANDS, AND CULTURAL RESOURCES IMPACTS**
- 6. EVALUATION OF ENGINEERING DESIGN**
- 7. PUBLIC COMMUNICATION**

APPENDICES

- Appendix 1 – Definitions of Hydrologic and Other Terms
- Appendix 2 – Technical Notes on Instream Flow Analyses
- Appendix 3 – Red-cockaded Woodpecker Agency Correspondence
- Appendix 4 – Determination of HSI Values for HEP Analyses
- Appendix 5 – FNI Geotechnical Investigation
- Appendix 6 – State Historic Preservation Officer Correspondence
- Appendix 7 – TWDB Comments on Draft Report and ANRA Comments

**TABLE OF CONTENTS
VOLUME II (on CD-ROM)**

- Appendix 1 – Remote Sensing Cover Type Forms
- Appendix 2 – FNI Wetland Letter
- Appendix 3 – FNI Wetland Field Forms
- Appendix 4 – FNI Wetland Maps
- Appendix 5 – Hicks and Company 1994a Guidance Document
- Appendix 6 – Hicks and Company 1994b Wetland Delineation Manual
- Appendix 7 – Hicks and Company 1994b Wetland Delineation Manual maps
- Appendix 8 – HEP Field Data Forms
- Appendix 9 – HEP Photographs
- Appendix 10 – FNI HEC-1 Model Runs
- Appendix 11 – Schaumburg & Polk Study

1.0 INTRODUCTION

The Angelina and Neches River Authority (ANRA) entered into an agreement with the Texas Water Development Board (TWDB) in March 2001 for a matching grant to conduct the current planning studies for the proposed Lake Eastex water supply project (TWDB Contract No. 2001-483-385). The purpose of these studies was to update and supplement some of the previous planning studies in order to develop a current estimate of probable cost to construct Lake Eastex. The ANRA's portion of funds for the current studies was derived from payments made by 20 participating entities (the participants) which consist of 8 municipalities, 1 county, 10 water supply corporations, and 1 industry that have entered into contracts with the ANRA for the Lake Eastex project.

The ANRA contracted with Freese and Nichols, Inc. (FNI) in May 2001 to assist with the current studies. Schaumburg and Polk, Inc. and E TTL Engineers and Consultants served as subconsultants to FNI in performing these studies.

1.1 Project Background

Initial planning for Lake Eastex was begun by the ANRA in 1978. ANRA's early efforts led to the issuance of a permit by the Texas Water Commission in 1985 to develop the reservoir on Mud Creek in Cherokee and Smith Counties (Figure 1-1) and to divert water for municipal and industrial uses. The ANRA's water right permit was amended in September 2001 and requires the Lake Eastex dam to be constructed by 2011.

In 1988, the ANRA secured a matching grant from the TWDB to perform a comprehensive regional planning study for the Lake Eastex project including investigations of water supply alternatives, reservoir physical conflicts, environmental impacts, and development costs (Lockwood, Andrews & Newnam, Inc., 1991; the "LAN study"). That study provided a detailed history of the project up to that point, and the reader is referred to that study for additional information not included in this planning study update. The LAN study also outlined the future steps necessary to acquire a U.S. Army Corps of Engineers' 404 permit and a

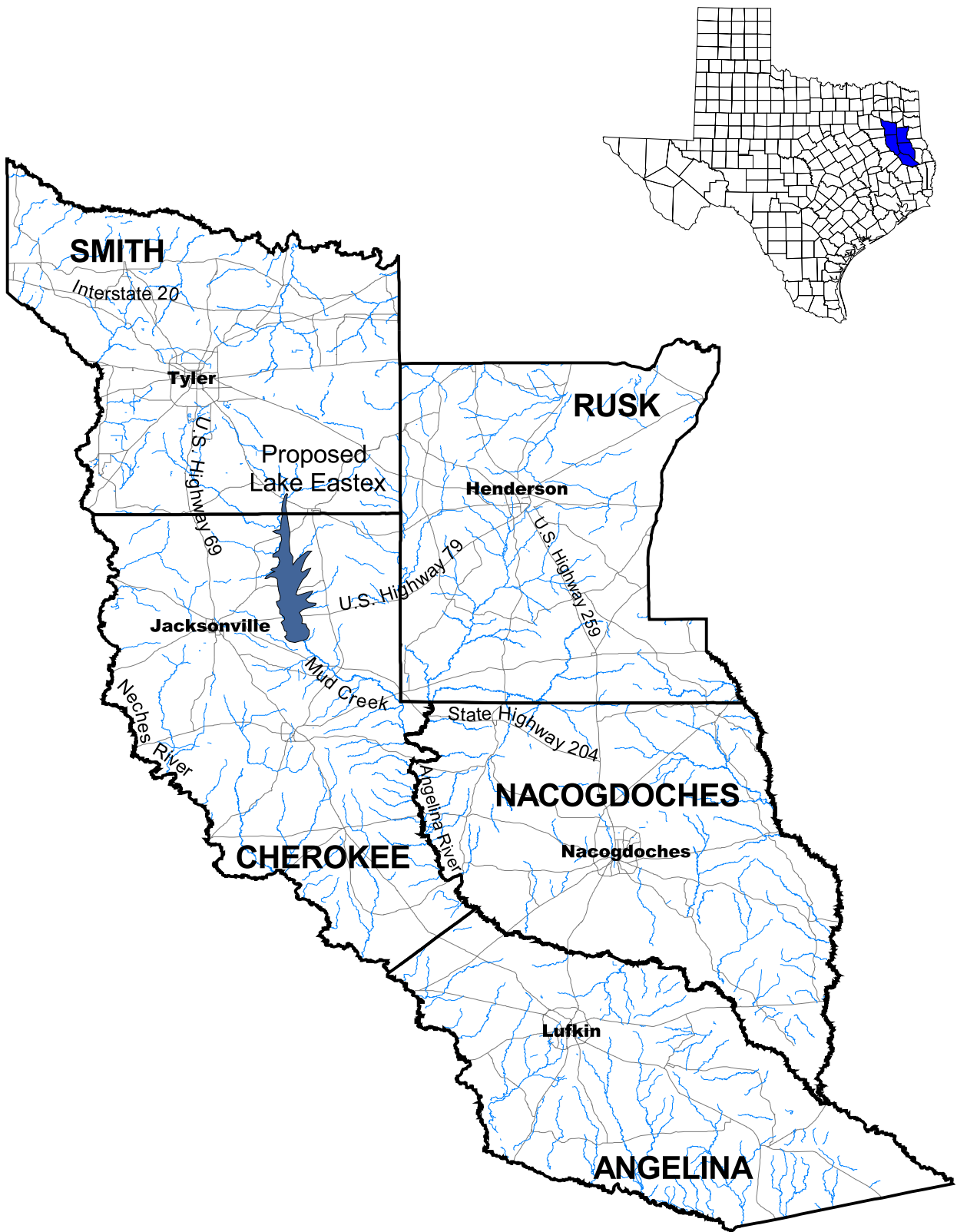

10 0 10 Miles



**Angelina and Neches River Authority
 Proposed Lake Eastex**

Location Map

FN JOB NO	ANR01289
FILE	MAPS.APR
DATE	May 21, 2003
SCALE	1:1,000,000
DESIGNED	TLH
DRAFTED	LDC

1-1

FIGURE

schedule for 1) financing the project, 2) designing the dam and related structures, 3) acquiring land, 4) conducting archeological mitigation, and 5) constructing the project. While Federal rules, regulations, and policies have changed since 1991, the LAN outline for development of the Lake Eastex project remains generally applicable.

In the years following completion of the LAN study, activity on the Lake Eastex project slowed. A number of factors contributed to this, including a change in ANRA's leadership, the tightening of regulatory requirements for such water projects, and the presence of a wetter climatic cycle leading to a general perception that water supplies were adequate for present demands.

Interest in the Lake Eastex project was renewed in the late 1990's when record or near-record drought conditions across Texas spawned legislation requiring the statewide water supply planning effort known as Senate Bill 1. The focus of Senate Bill 1 was to identify and plan for the expected water demands by region across the state for the next 50 years. Lake Eastex was identified by the East Texas Regional Planning Group (Region I) as a recommended strategy for meeting some of the projected demands in the East Texas region through the year 2050, and the proposed reservoir was adopted as a recommended supply strategy in the TWDB 2002 State Water Plan (TWDB 2002). The TWDB also included the Lake Eastex site as one of 20 recommended for designation and protection by the Texas Legislature as unique reservoir sites. A bill to establish the site will be considered during the 78 legislative session.

1.2 Description of the Proposed Lake Eastex

The proposed Lake Eastex dam will be constructed on Mud Creek approximately 5 miles southeast of Jacksonville, in Cherokee County, Texas, and approximately 3 miles downstream from the U.S. Highway 79 bridge on Mud Creek. The dam will impound water approximately 14 miles upstream and will inundate 10,000 acres at the conservation pool elevation of 315 feet National Geodetic Vertical Datum (NGVD). The 100-year flood would rise to an elevation of 323.3 feet NGVD. The Probable Maximum Flood (PMF), an extreme event used for dam design, would reach an elevation of 335.2 feet NGVD.

The proposed dam will be an earth fill structure with an impervious clay core and cutoff, a bentonite slurry trench to control seepage under the dam, and soil cement to control erosion on the upstream face of the dam. Concrete will also be used for some of the structural features of the dam, including the service spillway and the outlet works. The dimensions of the dam are presented in Table 1-1.

Table 1-1. Lake Eastex Dam Dimensions

Height above natural ground	74 feet
Maximum Elevation	336 feet NGVD
Length	6,800 feet
Service spillway length	200 feet
Service spillway elevation	315 feet NGVD
Emergency spillway length	1,100 feet
Emergency spillway elevation	324 feet NGVD
Outlet Works	2-48-inch diameter pipes

1.3 Objectives of the Current Planning Studies

The primary objective of conducting the studies described in this report was to update the estimated cost of developing the Lake Eastex project. Since development of the cost estimate in the 1991 LAN report, some of the information forming the basis for the cost estimate have become outdated; regulatory requirements and policies have tightened; the application of rules, regulations, and policies have changed; and engineering design and construction technologies have evolved in response to research and experience.

Rather than updating the earlier cost estimate by using an assumed inflation factor, ANRA decided that certain major components of the projected cost should be studied and changed as appropriate, leading to a revised overall project cost estimate for Lake Eastex. In addition, some questions that were left unanswered by previous studies needed to be addressed to refine the estimated cost of the project. The following studies were identified as the critical parts of the project cost that needed to be undertaken with the current planning grant:

- Effects of instream releases on reservoir yield
- Evaluation of the reservoir site for potential red-cockaded woodpecker habitat
- Assessment of wetland and terrestrial habitat impacts
- Identification of potential mitigation requirements
- Evaluation of the engineering design and update of the opinion of probable construction cost

The results of these studies are described in detail in the following sections of the report.

References

- Lockwood, Andrews and Newnam, Inc. (LAN) 1991. *Lake Eastex Regional Water Supply Planning Study*, prepared for Angelina and Neches River Authority, Houston, Texas.
- TWDB, 2002. *Water for Texas – 2002*. Volumes I – III. Document No. GP-7-1. Published by the Texas Water Development Board, Austin, Texas.

TABLE OF CONTENTS

		Page
2.0	INSTREAM FLOW EVALUATION.....	2-1
2.1	Methodology.....	2-1
2.1.1	Watershed and Reservoir Hydrology.....	2-1
2.1.2	Drainage Area.....	2-2
2.1.3	Daily Streamflow Patterns.....	2-2
2.1.4	Runoff.....	2-3
2.1.5	Net Evaporation.....	2-4
2.1.6	Demand Pattern.....	2-4
2.2	Area-Capacity Relationship.....	2-5
2.3	Return Flow.....	2-6
2.4	Bypass Flows.....	2-7
2.5	Results.....	2-8
	References.....	2-11

FIGURES		Page
	Figure 2-1. USGS Stream Gages.....	2-2
	Figure 2-2. USGS Stream Gage Period of Record.....	2-3
	Figure 2-3. Percent of Annual Water Demand by Month.....	2-5
	Figure 2-4. Area-Capacity Estimates for Initial and Sedimentation Conditions.....	2-6
	Figure 2-5. Yield of Lake Eastex Under Various Return Flow and Bypass Scenarios.....	2-9

TABLES		Page
	Table 2-1. Reservoir Yield Under Various Return Flow and Bypass Scenarios.....	2-10

2.0 INSTREAM FLOW EVALUATION

The purpose of this study was to evaluate a range of potential instream releases from Lake Eastex and identify the impacts of these releases on the firm yield of the lake. Although instream flow releases are not required by ANRA's water right permit, they may be required to obtain a Corps of Engineers Section 404 permit for construction of the proposed reservoir.

The **FIRM YIELD** is the amount of water that could be withdrawn annually from the reservoir under given environmental and management conditions leaving the reservoir empty at the end of the drought of record and resulting in no shortages.

Close interaction with ANRA and other project participants, government agencies, and non-government organizations provided a framework for this instream flow study and aided in the identification of feasible release scenarios. Previous studies by LAN (1984) and existing hydrologic data were used to identify appropriate methodologies and quantify potential impacts of instream release quantities on reservoir yield. The following sections include descriptions of the methodology and results of the study. Volume II, Appendix 2 includes a more technical summary of the instream flow analysis.

2.1 Methodology

The reservoir operation model used in this study was developed by Freese and Nichols, Inc. The model used a daily time-step to simulate reservoir response based on a suite of hydrologic and management variables. Hydrologic variables included watershed characteristics, area-capacity relationships of the reservoir, wastewater return flows, runoff and stream flow patterns, evaporation, and demands by existing water right holders. Four bypass methods and three return flow scenarios were analyzed based on both the original reservoir capacity and predicted capacity after 100 years of sedimentation.

OPERATION MODELS
help engineers predict the yield of a reservoir under various water management scenarios.

2.1.1 Watershed and Reservoir Hydrology

Modeling a hydrologic system to determine responses to management activities requires a thorough understanding of basic processes that govern the water balance. The OPERATE model was originally developed by Freese and Nichols and runs within Microsoft Excel. The

model is designed to simulate the behavior of a reservoir based on hydrologic and climatologic components specific to the reservoir site and its contributing watershed. The model has been used extensively in hydrologic and water quality modeling projects across Texas. Inputs to the Lake Eastex water budget included rainfall, runoff, and return flows, while outflows included evaporation, water right demands, and spills. The following paragraphs describe data that were used in modeling efforts and instream flow analyses for Lake Eastex.

2.1.2 Drainage Area

Figure 2-1. USGS Stream Gages

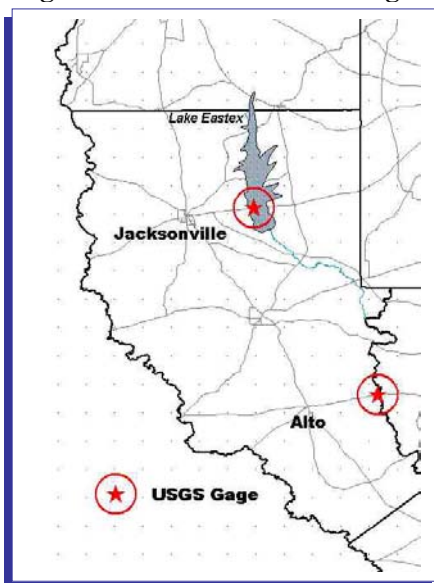

The drainage area, or watershed, of the reservoir is that area above the dam site (location of the proposed dam) that would naturally drain into the proposed reservoir. Watershed boundaries were delineated on USGS 7.5 minute topographic maps that were then digitized to determine the 384 square mile (sq. mi.) drainage area for Lake Eastex. Flow from the upper portion of the watershed is controlled by Lake Tyler and Lake Tyler East. Drainage areas of USGS gaging stations at Mud Creek near Jacksonville (376 sq. mi.) and the Angelina River near Alto (1,276 sq. mi.) were used to verify the Lake Eastex drainage area (Figure 2-1). Drainage area ratios for the dam site and USGS gaging stations were used to identify daily

streamflow patterns at the Lake Eastex dam site and in the formula to calculate runoff for Lake Eastex.

2.1.3 Daily Streamflow Patterns

Daily USGS streamflow data (USGS, 2001) from gages at Mud Creek near Jacksonville and the Angelina River near Alto were used to develop streamflows at the Lake Eastex dam site. These data were adjusted using the drainage area ratio between each USGS gage and the Lake Eastex dam site. Data from the Mud Creek gage were used as the primary data to characterize the daily streamflow pattern. During periods when the Mud Creek data were

STREAMFLOW PATTERNS

are affected by rainfall as well as seasonally. During periods when vegetation is dormant, stream flows may be higher.

not available, data from the Angelina River gage were used. Figure 2-2 illustrates the periods of record for each of the USGS stream gages.

Figure 2-2. USGS Stream Gage Period of Record

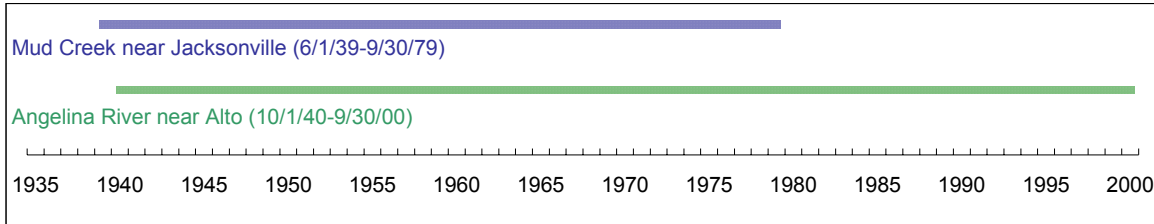

2.1.4 Runoff

Runoff refers to the water naturally flowing in a river or stream due to infiltration of groundwater, rainfall or other precipitation, and outflows from lakes controlling stream flow from upstream portions of the watershed. One source of runoff data is the Neches River Water Availability Model (WAM) (Brown and Root Services, et al. 2000) for the period between 1940 and 1996. Although the runoff values calculated in the Neches River WAM are incorrect, the raw data presented in the report are valid. The raw data were used in this study. These data included outflow measurements from Lake Tyler and Lake Tyler East as well as naturalized flow recorded at USGS stream gages at Mud Creek near Jacksonville and Mud Creek near Tyler. Appendix 2 includes a more detailed discussion of the problem with curve numbers in the Neches WAM.

NATURALIZED STREAM FLOW
 are flows that would historically occur without human impact in the watershed. Once naturalized flows are determined, water rights are subtracted in priority order to determine availability for other purposes, such as instream flows.

Drainage area ratios were used to adjust the runoff at the two stream gages to provide an estimate of runoff at the dam site. The drainage area ratio is the drainage area of the dam site divided by the drainage area of each stream gage. The drainage area ratios are multiplied by the naturalized flow at the appropriate stream gage to estimate runoff at the dam site.

The following formula was used to calculate runoff entering Lake Eastex:

$$\text{Runoff} = \text{Spills from Tyler Lakes} + \frac{\text{Nat. Flow (MU_JA - MU_TY)} \times (\text{D.A. Dam Site} - 107)}{\text{D.A. USGS gage} - 107}$$

Notes:

Nat.Flow (MU_JA – MU_TY) = the naturalized flow of Mud Creek near Jacksonville minus the naturalized flow of Mud Creek near Tyler(1940-1996).

D.A. = drainage area in sq. mi.

USGS gage = Mud Creek from 1/40 to 9/79 and Angelina River near Alto from 10/79 to 12/96

107 = the drainage area (sq. mi.) controlled by the Tyler Lakes.

2.1.5 Net Evaporation

The monthly net evaporation rate (FNI 2001) was derived from Texas Water Development Board (TWDB) monthly gross evaporation data, TWDB precipitation data, and drainage area runoff. The net evaporation is equal to the gross evaporation plus the runoff less the precipitation. Daily net evaporation rate was calculated by distributing monthly net evaporation evenly across the number of days in the month.

2.1.6 Demand Pattern

Water demands consist of withdrawals from the reservoir. The demand pattern is expressed as the percent of expected annual water demand for each month of the year. The demand pattern exhibited by Lake Eastex was typical in that it illustrated higher usage during summer months and lower usage during winter months.

The demand pattern presented in the 1984 Lockwood, Andrews and Newnam report (LAN 1984) (Figure 2-3) for Lake Eastex was considered to be the most appropriate for this study. To develop a daily demand pattern, the monthly demand was distributed evenly across the number of days in each month.

Figure 2-3. Percent of Annual Water Demand by Month

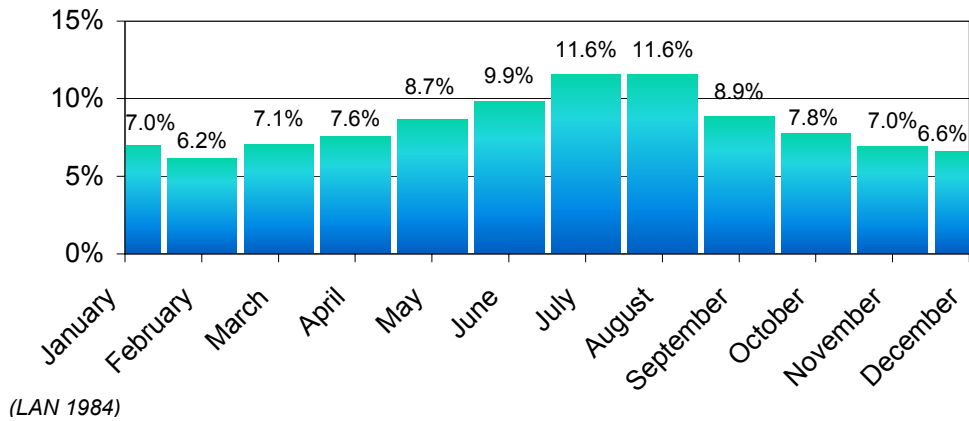

2.2 Area-Capacity Relationship

The area-capacity-elevation (ACE) relationship describes both the area of land inundated by the reservoir and the volume of water contained in the reservoir for each elevation between the lowest possible water level (empty) and the conservation storage elevation. LAN (1984) developed ACE relationships to represent initial reservoir conditions and conditions after 100 years of sedimentation (Figure 2-4). Both relationships were used in this study to analyze the loss of yield in the reservoir due to sedimentation. The top of conservation storage elevation for Lake Eastex is 315 feet NGVD.

AREA CAPACITY RELATIONSHIP
describes how much water is in the reservoir at various water levels.

Figure 2-4. Area-Capacity Estimates for Initial and Sedimentation Conditions

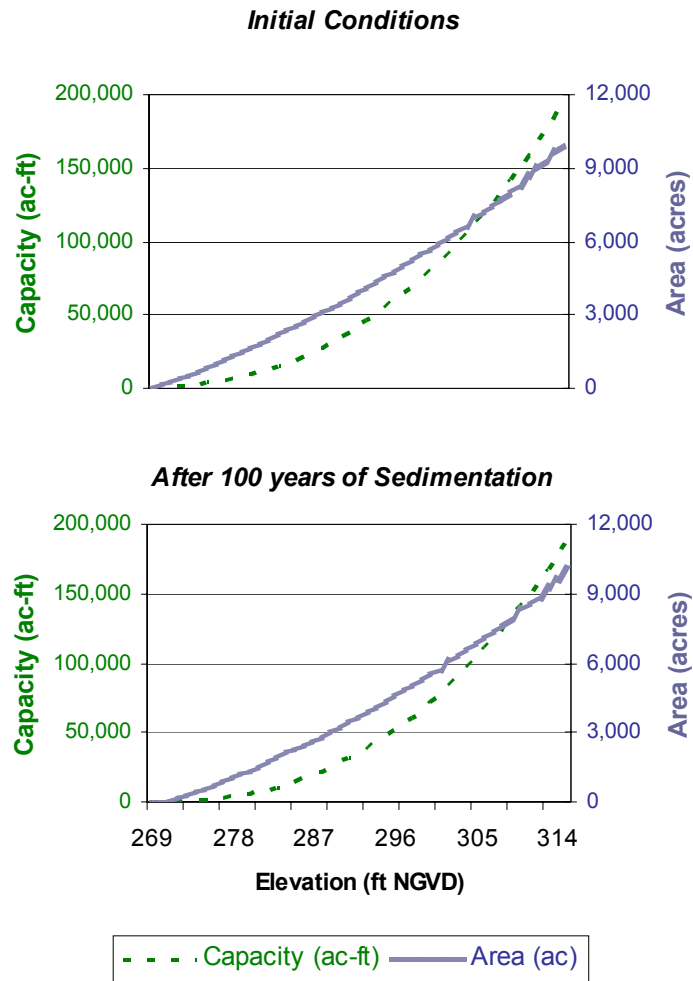

2.3 Return Flow

Return flows are those treated flows discharged from wastewater treatment plants into streams and rivers. The yield of Lake Eastex was analyzed with three return flow scenarios: return flows at current permit levels of 9.99 million gallons per day (MGD), actual discharge levels of 4.66 MGD, and without upstream return flows. Permitted values include those of Tyler, Whitehouse, and Troup. Actual discharge values include only Tyler.

2.4 Bypass Flows

In the Lake Eastex study, four hypothetical bypass flow scenarios were analyzed to determine the impact of the bypass releases on the yield of the proposed reservoir. These included: no bypasses, up to five cubic feet per second (cfs) when available, up to ten cfs when available, and volumes calculated using the Consensus method (TWDB 2002).

Inclusion of the “no bypass” scenario provides insight into the maximum attainable yield of the reservoir, and provides a framework for assessing the impact of release strategies on yield. However, it is not the intention of ANRA to retain all flows from the reservoir. The “no bypass” scenario is included only for independent comparison of the other three strategies. Bypassing inflows up to five or ten cfs would augment local runoff, ground water, and return flow contributions to the stream below Lake Eastex while not substantially reducing reservoir yield.

The Consensus bypass was developed as a rapid, desktop assessment tool by collaboration among TWDB, Texas parks and Wildlife Department, TCEQ, and other scientists for State and regional water supply planning purposes. The methodology utilizes historical USGS streamflow data and is sometimes used for analyzing inflows to be released from a proposed reservoir project. As discussed in the Texas Water Plan (TWDB 2002), the Consensus criteria include median, first quartile, and 7-day, 2-year low flows (7Q2) as bypass flow rates, depending on reservoir levels at the time of bypass. These planning level criteria resulted in bypass rates that exceeded 10 cfs (Appendix 2).

BYPASS FLOW is water released from a reservoir to help meet downstream water needs.

METHODS ANALYZED:

- No bypass
- Up to 5 cfs
- Up to 10 cfs
- Consensus Method

2.5 Results

Figure 2-5 illustrates the yield of Lake Eastex under each scenario analyzed in the study. Details of yield, content, and critical period for each scenario are presented in Appendix 2. As would be expected, the yield of the reservoir is highest under original conditions with maximum return flows and minimum bypasses, and decreases with decreasing return flows and increasing bypasses. Reservoir yield for each scenario is presented in Table 2-1.

When results for original and 100 year sedimentation conditions were compared, original capacity conditions provided higher yields. This is not surprising, as sedimentation would naturally decrease the volume of water that the lake could hold. Modeling results indicated that sedimentation would result in a three to four percent decrease in yield over 100 years regardless of which return flow or bypass scenario was applied.

Under original conditions, the maximum yield of 91,040 ac-ft/yr occurs under the scenario with maximum return flow (9.99 MGD) and no bypass flows. Decreasing return flows from 9.99 MGD to 4.66 MGD impacted reservoir yield by approximately 6 percent. Decreasing return flows from 9.99 MGD to zero MGD resulted in a decrease of approximately 12 percent in yield. Similar results were observed for sedimentation conditions.

Modeling results indicate that the selection of bypass flow methodology plays a more substantial role than return flow scenarios in determining reservoir yield. Under current conditions, maximum yield was observed under the zero bypass scenario. When bypasses were increased from zero to five cfs, reservoir yield decreased approximately four percent. When bypasses were increased from zero to ten cfs, reservoir yield decreased approximately 8 percent. When the Consensus bypass method was applied, reservoir yields decreased approximately 16 percent from the yield observed if no bypasses were made. In each case, the least impact on reservoir yield due to bypass methodology was observed under the zero MGD return flow scenario.

Figure 2-5 Yield of Lake Eastex Under Various Return Flow and Bypass Scenarios

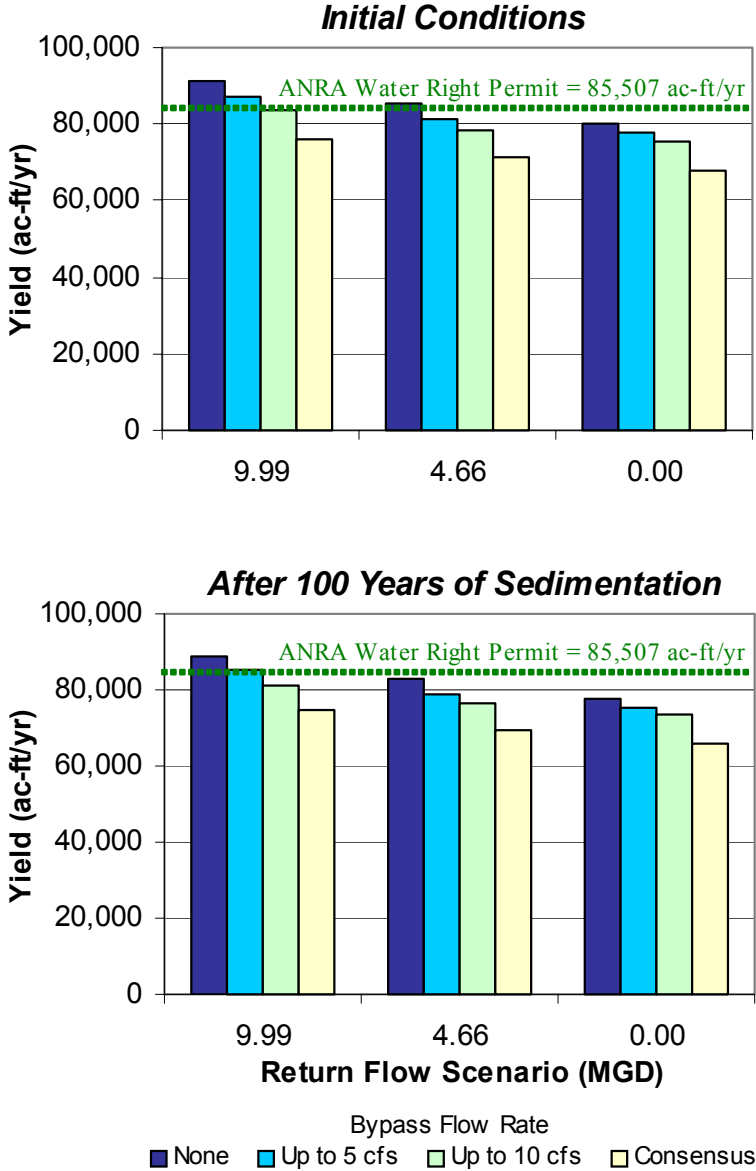

Table 2-1 Reservoir Yield Under Various Return Flow and Bypass Scenarios

Initial Conditions

Return Flow (MGD)	Reservoir Yield (ac-ft/yr)			
	No Bypass	up to 5 cfs	up to 10 cfs	Consensus
9.99	91,040	87,360	83,690	76,270
4.66	85,090	81,415	78,600	71,285
0.00	79,880	77,600	75,420	67,600

After 100 Years of Sedimentation

Return Flow (MGD)	Reservoir Yield (ac-ft/yr)			
	No Bypass	up to 5 cfs	up to 10 cfs	Consensus
9.99	88,730	85,050	81,380	74,480
4.66	82,780	79,105	69,490	69,490
0.00	77,570	75,380	65,830	65,830

References

- Brown and Root Services, Freese and Nichols, Espey-Padden, and Crespo Consultants. 2000. *Water Availability Modeling for the Neches River Basin*, prepared for the Texas Natural Resource Conservation Commission, Austin, Texas.
- Lockwood, Andrews and Newnam, Inc. 1984. *Engineering Report on Eastex Reservoir*, prepared for Angelina and Neches River Authority, Houston, Texas.
- U.S. Geological Survey: Streamflow Gage Records, [online], (September 2001) at URL: <http://tx.usgs.gov/cgi-bin/txnwis>.
- Freese and Nichols, Inc. (FNI) Evaporation and Precipitation (1940-1996) developed by Freese and Nichols from Texas Water Development Board Quadrangle Evaporation [online], (September 2001) at URL: <http://hyper20.twdb.state.tx.us/Evaporation/evap.html>.
- Texas Water Development Board. *Environmental Water Needs Criteria of the Consensus Planning Process*, Austin, Texas.
- Texas Water Development Board. 2002 *Water for Texas*, Austin, Texas.

TABLE OF CONTENTS

	Page
3.0 RED-COCKADED WOODPECKER HABITAT STUDY.....	3-1
3.1 Natural History of the Red-cockaded Woodpecker	3-1
3.2 Assessment of Potential RCW Habitat	3-3
3.2.1 Results of Field Investigations.....	3-4
3.2.2 Conclusion	3-6
References.....	3-8

FIGURES	Page
Figure 3-1. Potential Red-cockaded Woodpecker Habitat as Identified by Parker (1993)	after page 3-3
Figure 3-2. Potential Red-cockaded Woodpecker Habitat, Map From Parker (1993)	after page 3-3
Figure 3-3. Potential Red-cockaded Woodpecker Sites I, II, and III, As Identified by Parker (1993) superimposed on August 2001 Aerial Photography	after page 3-3

3.0 RED-COCKADED WOODPECKER HABITAT STUDY

The red-cockaded woodpecker (*Picoides borealis*) (RCW) is a federally listed endangered species known to occur in Cherokee County. An evaluation of the potential occurrence of nesting and foraging habitat for the species was performed as part of this planning study.



The red-cockaded woodpecker is a relatively small, non-migratory native species listed as endangered by the U.S. Fish and Wildlife Service (USFWS 1985). The decline in population has been attributed to the decrease of suitable nesting and foraging habitat brought about by silvicultural and agricultural activities, urbanization, and fire suppression (USFWS 1985). RCWs require open, mature pine and pine-oak forests with limited woody understory for nesting and foraging. Historically, red-cockaded woodpeckers were common in old growth pine forests from eastern Texas to Florida and north to New Jersey and can still be found in the southeastern coastal states (USFWS 1985). The potential impact on the species by the proposed project was evaluated by assessing the potential RCW habitat in the proposed Lake Eastex reservoir area.

3.1 Natural History of the Red-cockaded Woodpecker

RCWs are “ladder-backed” woodpeckers, about 7-1/4 inches in length, with white cheek patches and dull white flanks and bellies. Their flanks, the perimeters of their bellies, and their white outer tail feathers are spotted with black. Males have a few red feathers on the sides of their heads, forming the red cockades for which the birds are named.

The species is unique among woodpeckers in that it forms family units, called clans. Clans consist of a mating pair, hatchlings, and often one to three helpers. Helpers are the male offspring of previous breeding seasons who help to rear the current year’s brood. Female offspring are known to disperse soon after fledging (Hooper et al. 1996). RCW clans with helpers are reported to have higher brood survival rates than those without helpers (USFWS 1985).

RCWs excavate nests and roosting cavities exclusively in living trees rather than the dead trees preferred by many other woodpecker species (USFWS 1985). To maintain sap wells around their cavity entrances, RCWs actively remove bark and scar tissue, resulting in an accumulation of white sap on the tree trunk. The sap around an active nest cavity is white in color but turns grey after nest cavities have been abandoned (USFWS 1985).

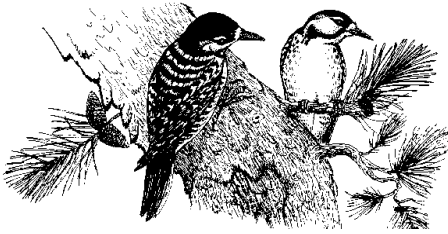

Nesting generally occurs in mature, open longleaf pine forests (*Pinus palustris*) with little to no woody understory, but is also known to occur in forests of slash pine (*P. elliottii*), shortleaf pine (*P. echinata*), loblolly pine (*P. taeda*), pitch pine (*P. rigida*) and pond pine (*P. serotina*). RCWs prefer trees at least sixty years old (USFWS 1985) that are infected with red-heart disease. Red-heart disease softens heartwood and makes cavity excavation easier (Rudolph et al. 1995). RCW clans excavate roosting and nesting cavities in adjacent or nearby trees to create clusters. The birds abandon nests and cluster areas if dense understories become established.

Home range territories are often at least 100 acres in size but can be larger than 250 acres, depending on habitat quality (Hooper et al. 1996). The average clan territory occupies approximately 210 acres (McFarlane 1995).

While home territory size is important for RCW survival, a better measure of breeding success is foraging habitat area (USFWS 1985). RCWs prefer to forage on old growth pine tree trunks and limbs, where they glean for spiders, insects, and other arthropods which make up the majority of their diet (Hooper et al. 1980). Male RCWs tend to forage on limbs and upper tree trunks, while female RCWs feed primarily on the lower portions of the trunks. Individuals defend the area around their cluster from foraging by other clans (Winkler et al. 1995).

Quality RCW foraging habitat consists of mature pine or pine/hardwood stands. Clans will forage on pines scattered in hardwood stands, but not on pure hardwood stands (Hooper et al. 1980). An RCW clan requires approximately 125 acres of accessible, quality foraging habitat to maintain viable breeding productivity (USFWS 1985). Hooper et al. (1980) provide a somewhat more conservative minimum estimate (100 acres) of quality habitat, but also state that clans foraging in less than ideal conditions may require several hundred acres or more.

3.2 Assessment of Potential RCW Habitat

In 1993, the Texas Parks and Wildlife Department (TPWD) reported the results of an endangered species habitat study at the proposed Lake Eastex reservoir site (Parker 1993). Parker evaluated 37 areas within the conservation pool area for potential RCW habitat: 33 sites were found to not be suitable habitat and four were thought to contain potential habitat but needed further evaluation. Two other sites outside of the Lake Eastex conservation pool area were mapped as suitable RCW habitat (Figure 3-1, Figures 3-2a and 3-2b).

The objective of this portion of the Lake Eastex Planning Studies was to evaluate the sites that Parker did not fully evaluate and update the assessment for the presence of suitable RCW habitat at the sites. The first step to meet this objective was to analyze the data presented by Parker (1993) followed by coordination with TPWD and USFWS personnel familiar with local distribution of the RCW. Copies of the agencies' responses to information requests on the potential occurrence of the RCW or its habitat within the Lake Eastex conservation pool area are included in Appendix 3. The final part of this RCW habitat assessment was to ground-truth the sites within the conservation pool area by a qualified wildlife biologist (USFWS Permit No. TE024791-1) to determine if there was suitable RCW habitat present.

Prior to ground truthing, FNI mapped the potential habitat areas inside the conservation pool area on August 2001 aerial photography (Figures 3-3a and 3-3b) to help identify features that could indicate the potential for RCW habitat in the areas of question. On February 20, 2002 and June 19 and 20, 2002, FNI personnel conducted site visits to the six sites identified by Parker (1993) as having potential RCW habitat (Figure 3-1). Current RCW habitat conditions were assessed at these sites according to verbal guidance provided by USFWS and TPWD biologists through telephone conversations and by methods included in the *Guidelines for Preparation of Biological Assessments and Evaluations for the Red-cockaded Woodpecker* (Henry 1989) and procedures included in FNI biologists' endangered species permit (No. TE024791-1).

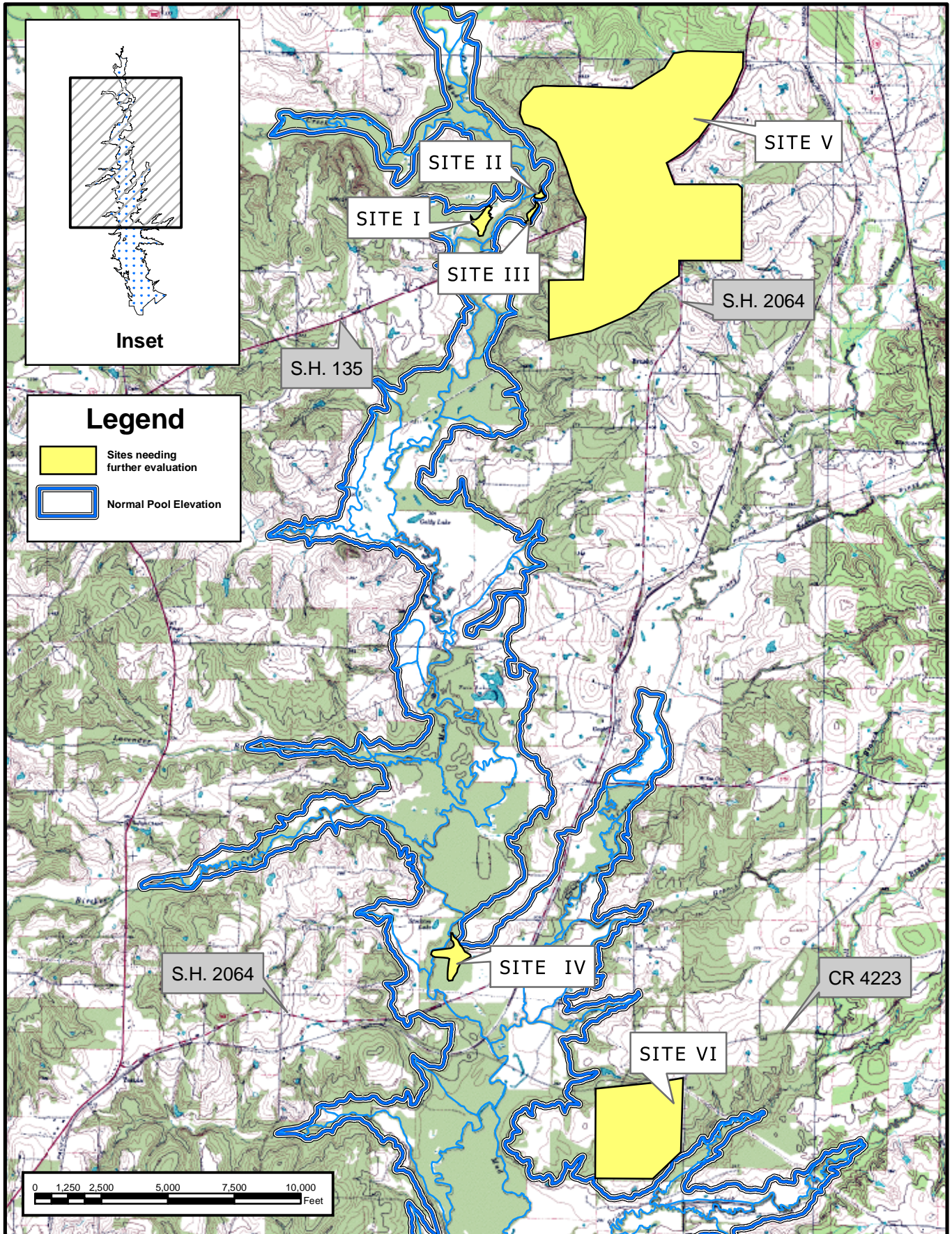

FN
FRESE • NICHOLS
 4055 International Plaza Suite 200
 Fort Worth, Texas 76109-4895
 817-735-7300

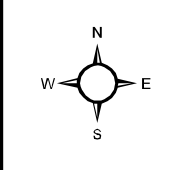

**Angelina and Neches River Authority
 Proposed Lake Eastex**

**Potential Red-cockaded Woodpecker
 Habitat Sites Redrawn from Parker (1993)**

FN JOB NO	ANR01289
FILE	H/RCW/RCW topo.mxd
DATE	January 15, 2003
SCALE	1:18,000
DESIGNED	RH
DRAFTED	BAR

**3-1
 Figure**

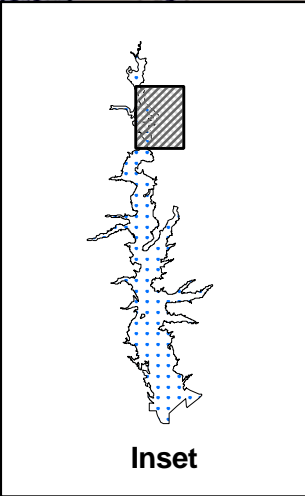
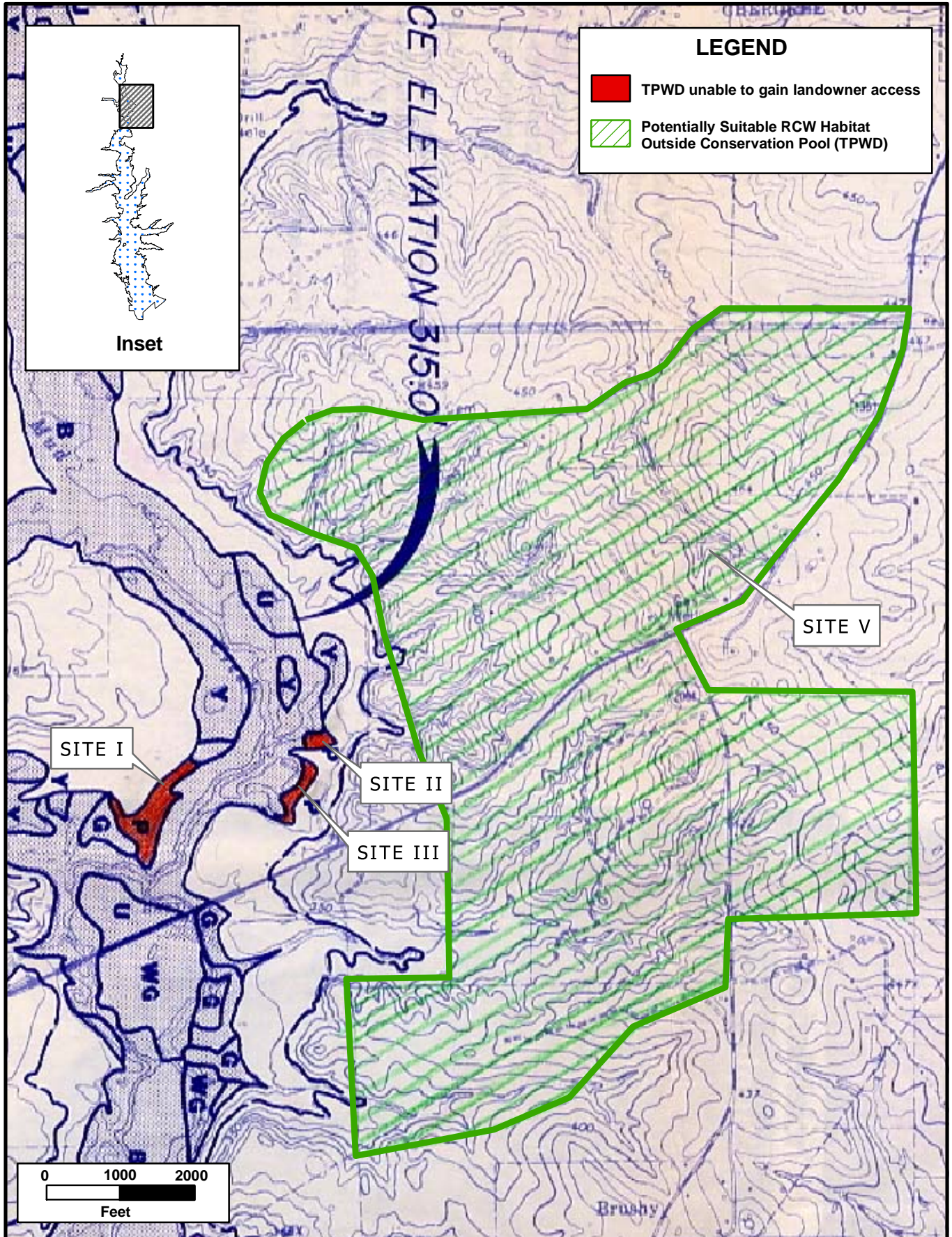

LEGEND

- TPWD unable to gain landowner access
- Potentially Suitable RCW Habitat Outside Conservation Pool (TPWD)

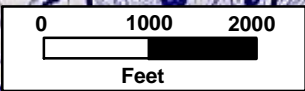

FREESSE • NICHOLS
4055 International Plaza Suite 200
Fort Worth, Texas 76109-4895
817-735-7300

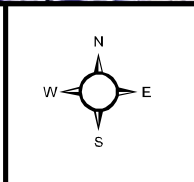

**Angelina and Neches River Authority
Proposed Lake Eastex**

**Potential Red-cockaded Woodpecker Habitat
Map from Parker (1993)**

FN JOB NO	ANR01289
FILE	H:/RCW/OldMaps1.mxd
DATE	January 15, 2003
SCALE	
DESIGNED	RH
DRAFTED	BAR

3-2a
Figure

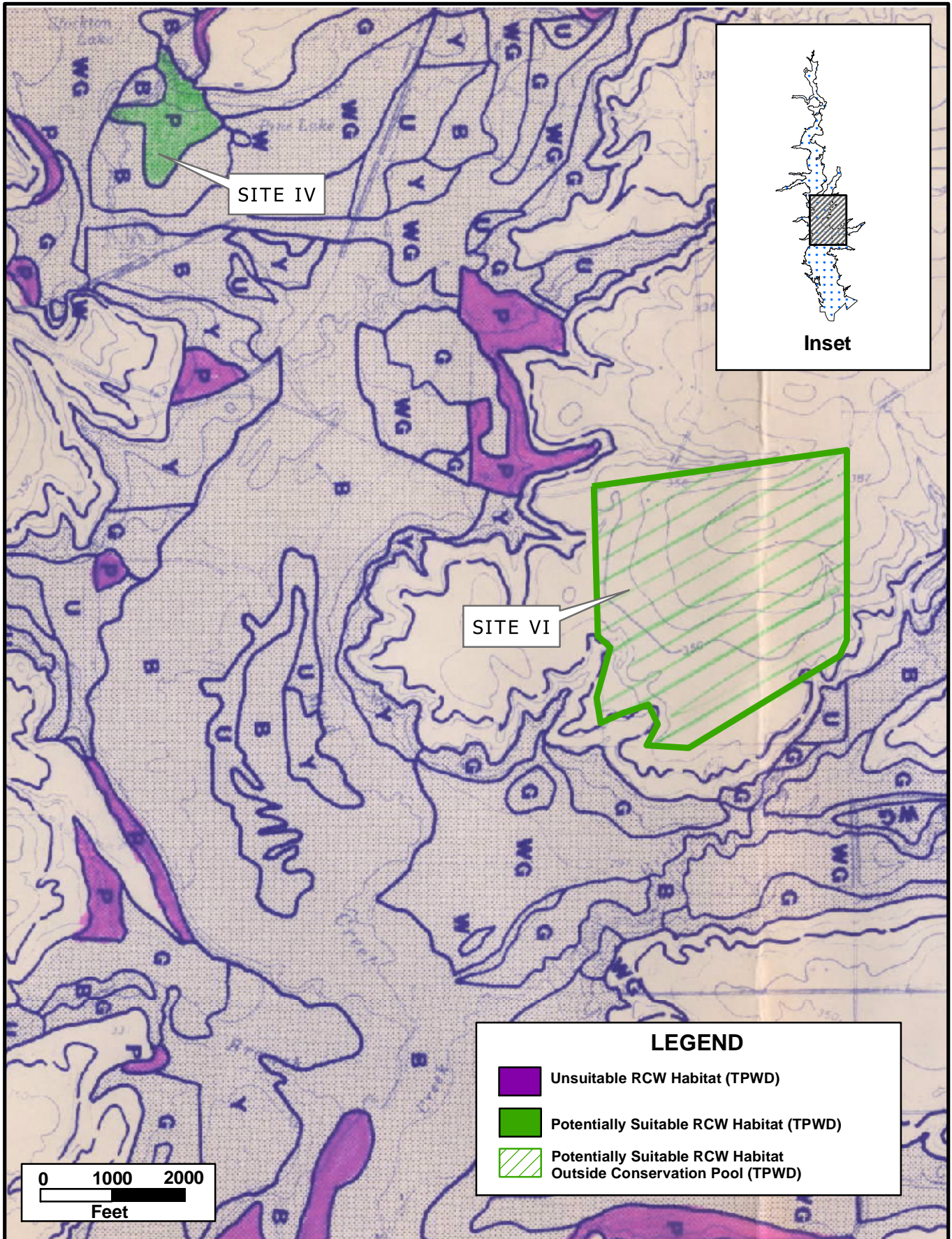

FN
FREESE • NICHOLS
 4055 International Plaza Suite 200
 Fort Worth, Texas 76109-4895
 817-735-7300

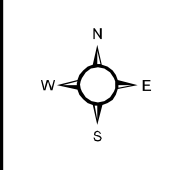

**Angelina and Neches River Authority
 Proposed Lake Eastex**

**Potential Red-cockaded Woodpecker Habitat
 Map from Parker (1993)**

FN JOB NO	ANR01289
FILE	H:/RCW/OldMaps2.mxd
DATE	January 15, 2003
SCALE	
DESIGNED	RH
DRAFTED	BAR

3-2b
Figure

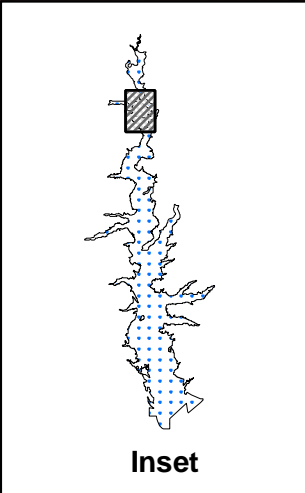
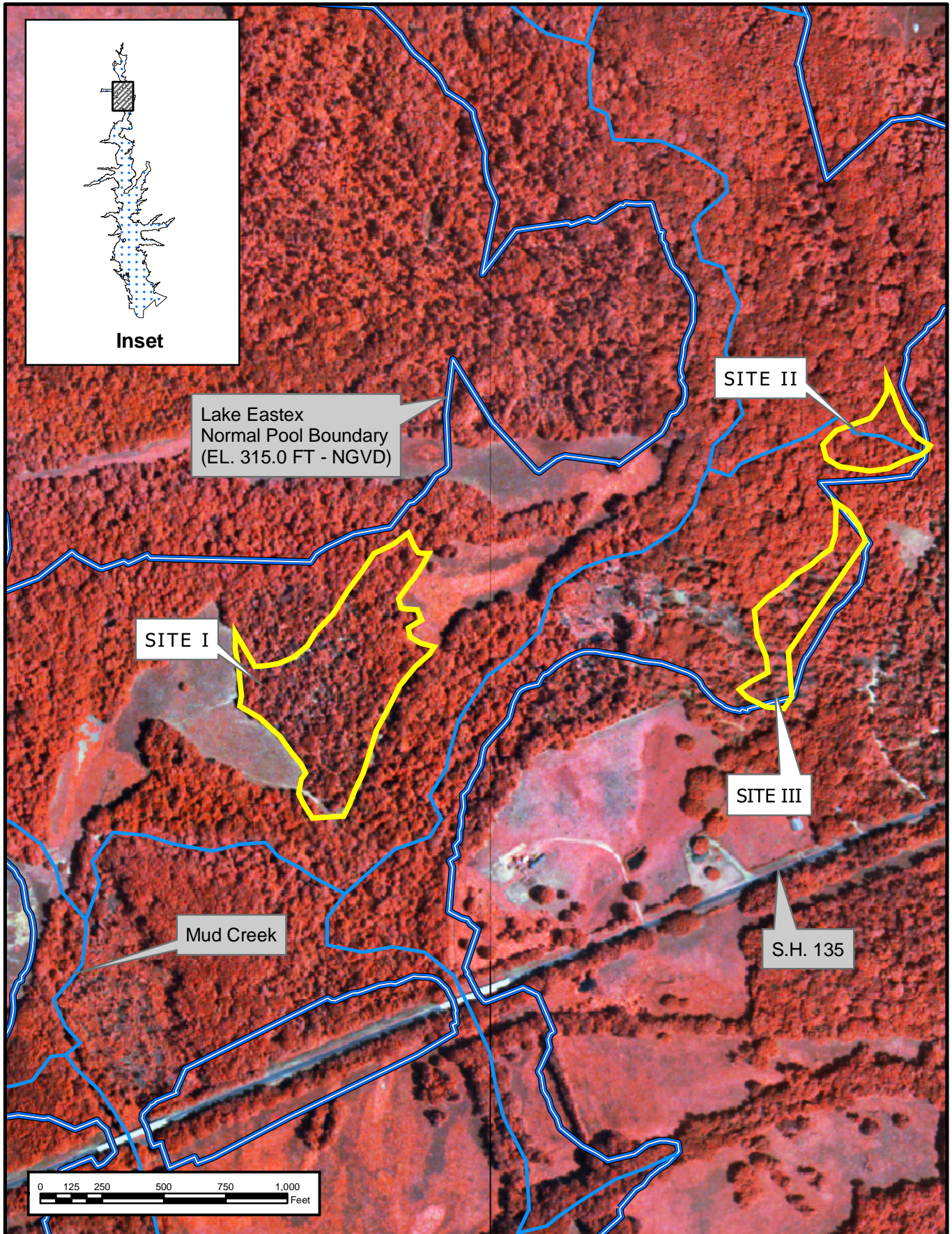

Lake Eastex
Normal Pool Boundary
(EL. 315.0 FT - NGVD)

SITE I

SITE II

SITE III

Mud Creek

S.H. 135



FN
FREESE • NICHOLS
4055 International Plaza Suite 200
Fort Worth, Texas 76109-4895
817-735-7300

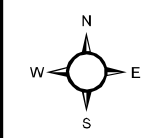

**Angelina and Neches River Authority
Proposed Lake Eastex**

**Potential Red-cockaded Woodpecker Sites I, II, and III
As Identified By Parker (1993)
Superimposed on August 2001 Aerial Photography**

FN JOB NO	ANR01289
FILE	H:/RCW/Sites1-3_aerial.mxd
DATE	January 15, 2003
SCALE	1:2,000
DESIGNED	RH
DRAFTED	BAR

3-3a
Figure

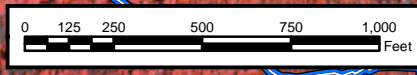
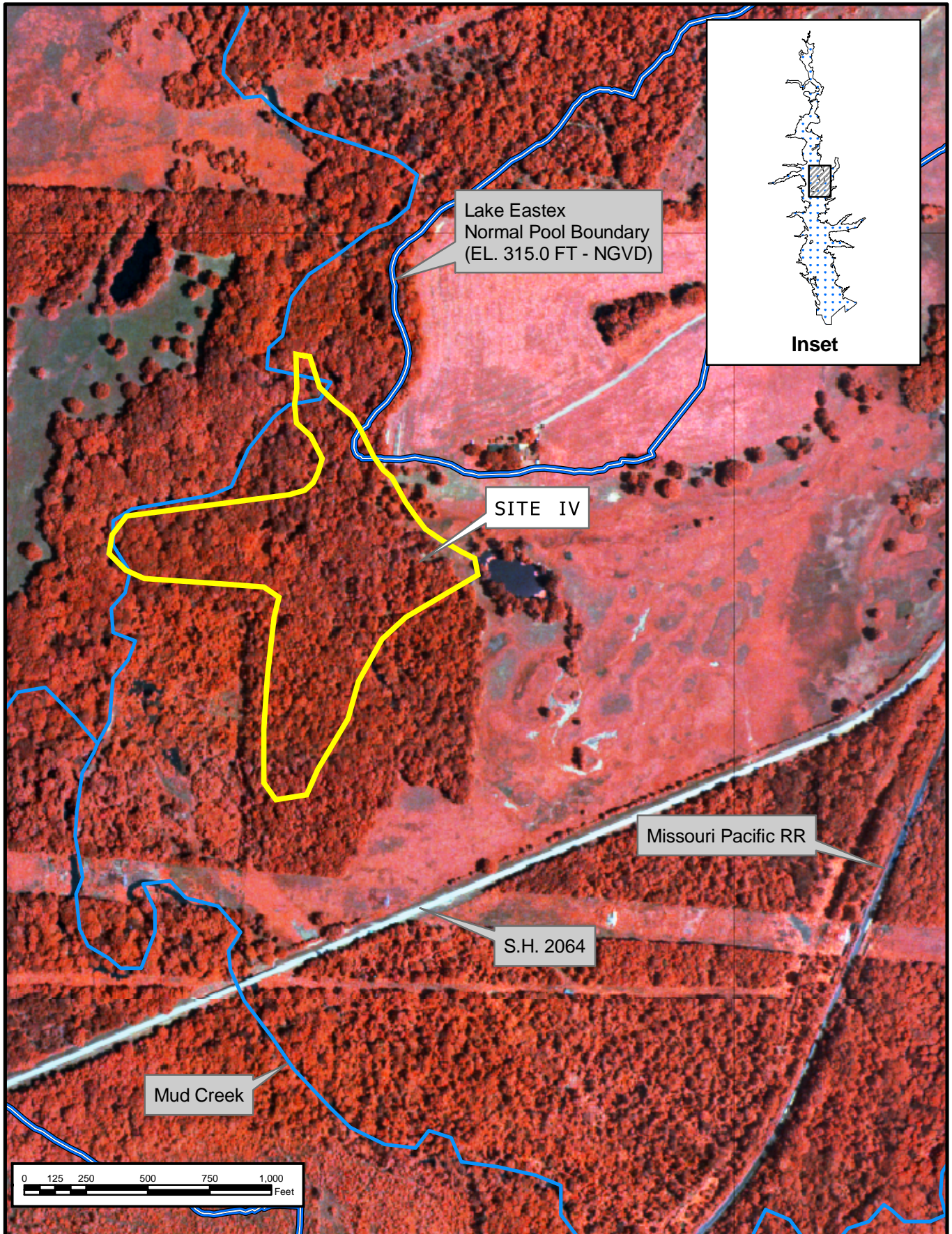

FREESE • NICHOLS
 4055 International Plaza Suite 200
 Fort Worth, Texas 76109-4895
 817-735-7300

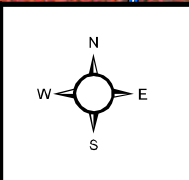

**Angelina and Neches River Authority
 Proposed Lake Eastex**

**Potential Red-cockaded Woodpecker Site IV
 As Identified By Parker (1993)
 Superimposed on August 2001 Aerial Photography**

FN JOB NO	ANR01289
FILE	H:/RCW/Site4_aerial.mxd
DATE	January 15, 2003
SCALE	1:2,000
DESIGNED	RH
DRAFTED	BAR

3-3b
Figure

3.2.1 Results of Field Investigations

Site I is situated within a braided section of Mud Creek toward the northern end of the proposed Lake Eastex project area (Figure 3-1) and is approximately 11 acres in size. At the time of the FNI study, the site was inaccessible to field personnel. Field observations of existing habitat were made from two locations on an adjacent property across Mud Creek.

Examination of aerial photographs of the project area indicates that this site and the immediate area are dominated by bottomland hardwood forest (Figure 3-3a). Field observations verified that the site contains bottomland hardwood forest dominated by water oak (*Quercus nigra*), overcup oak (*Q. lyrata*), and sweetgum (*Liquidambar styraciflua*). A dense, woody understory is present, consisting of species such as deciduous holly (*Ilex decidua*), water hickory (*Carya aquatica*), and planer trees (*Planera aquatica*). No mature pine trees were visible from either observation point.

No RCWs or RCW cavities were seen within the site. Due to the lack of mature pine trees and the relatively small size of the site, it was concluded that Site I does not contain suitable RCW nesting or foraging habitat.

Site II is an approximately 18-acre site located about ¼ mile northeast of Site I (Figures 3-1 and 3-3a). Field observations at the site indicate the site is bottomland hardwood forest dominated by overcup oak, willow oak (*Q. phellos*) and sweetgum, with a sparse woody understory of planer trees and black tupelo (*Nyssa sylvatica*). No mature pine trees, RCWs, or RCW cavities were seen within the site. No potential RCW nesting or foraging habitat was observed.

Site III is located less than 1/8 mile south of Site II and has a total area of approximately 3.2 acres (Figures 3-1 and 3-3a). Field observations at the site revealed that an area of between one and two acres within the site had been recently logged. The cover type of the forested area is bottomland hardwood dominated by sweetgum, overcup oak, and willow oak, with a dense, woody understory dominated by deciduous holly. No mature pine trees, RCWs or RCW cavities were observed within the site. No potential RCW nesting or foraging habitat was observed.

Site IV is located directly north of the State Highway 2064 bridge over Mud Creek (Figure 3-1 and 3-3b). The site encompasses approximately 26 acres and is situated on two private properties. Field observations at the site revealed that the vegetative cover-type is primarily bottomland hardwood forest and appears to be consistent with Mud Creek forested bottomlands in the area (Figure 3-3b). Dominant hardwoods observed in Site IV include water oak and sweetgum. The dense, woody understory is comprised of such species as eastern hop-hornbeam (*Ostrya virginiana*), red maple (*Acer rubrum*), water oak, water tupelo (*N. aquatica*), sweetgum, American holly (*I. opaca*), and American beautyberry (*Callicarpa americana*). Scattered loblolly and shortleaf pines were observed within the site, and a small clump of mature pines mixed with various hardwoods was observed on the northern end of the site. No RCWs or RCW cavities were observed within the site. Due to the dense woody understory, no RCW foraging habitat or potential RCW nesting habitat was observed.

The two areas outside of this planning study project area (Sites V and VI) were evaluated for potential RCW habitat by reconnaissance from available vantage points on public roads. Inspection of the available aerial photographs did not reveal any signatures (open, mature pine tree stands) that indicated potential RCW habitat.

Site V is an approximately 1,100-acre site located outside of the northern end of the Lake Eastex project area (Figure 3-1). Because access was unavailable to the various private properties within this site, the area was observed from adjacent public roads. This site consists of numerous private properties with a mosaic of land uses. While a few scattered mature pines were seen, no open, mature pine forests were observed. No RCWs, RCW cavities or potential RCW habitat were observed.

Site VI is located south of the Lake Eastex project area and covers an area of approximately 260 acres (Figure 3-1). Access to private property within the site was unavailable, so the perimeter was surveyed from public roads. The area consists of a mosaic of land uses and cover types including pine plantations, hardwood/pine forest, and pasture. Two small isolated stands of mature pines were observed within the area, but no RCWs or RCW cavities were observed.

3.2.2 Conclusion

Based on consultation with USFWS and TPWD personnel familiar with the RCW distribution in East Texas and on field observations made by Freese and Nichols' qualified wildlife biologists, no areas of potential RCW habitat were observed within the proposed Lake Eastex conservation pool area. Additionally, personal communications on August 29, 2001 with Bill Rose of the Texas Forest Service and James Houser, a local consulting forester, indicated no personal knowledge of RCWs or suitable forest stand characteristics occurring within the Lake Eastex site. Areas previously identified by Parker (1993) were evaluated and were eliminated as potential suitable RCW habitat based on size of stand, vegetation characteristics or proximity to suitable foraging habitat.

References

- Henry, V.G. 1989. Guidelines for Preparation of Biological Assessments and Evaluations for the Red-cockaded Woodpecker.
- Hooper, R.G., A.F. Robinson, and J.A. Jackson. 1980. The Red-cockaded Woodpecker: Notes on Life History and Management. General Report SA-GR 9, Atlanta, Georgia: U.S. Department of Agriculture, Forest Service, Southeastern Region.
- McFarlane, R.W. 1995. The Relationship Between Body size, Trophic Position and Foraging Territory Among Woodpeckers. Red-cockaded Woodpecker Recovery, Ecology and Management. Ed. by D.L. Kulhavy, R.G. Hooper and R. Costa. Center for Applied Studies in Forestry, College of Forestry. Stephen F. Austin State University, Nacogdoches, Texas.
- Parker, M. 1993. Results of a Preliminary Investigation of Endangered Species Habitat at the Proposed Site of Lake Eastex Reservoir. Texas Parks and Wildlife Department.
- Rudolph, D.C., R.N. Conner, and R.R. Schaefer. 1995. Red-cockaded Woodpecker Detection of Red Heart Infection. Red-cockaded Woodpecker Recovery, Ecology and Management. Ed. by D.L. Kulhavy, R.G. Hooper and R. Costa. Center for Applied Studies in Forestry, College of Forestry. Stephen F. Austin State University, Nacogdoches, Texas.
- U.S. Fish and Wildlife Service (USFWS). 1985. Red-cockaded Woodpecker Recovery Plan. U.S. Fish and Wildlife Service, Atlanta, Georgia.
- Winkler, H., D.A. Christie, D. Hurney. 1995. Woodpeckers: A Guide to the Woodpeckers of the World. Houghton Mifflin Company. New York, New York.

TABLE OF CONTENTS

		Page
4.0	ASSESSMENT OF WETLAND AND TERRESTRIAL HABITAT	4-1
4.1	Remote Sensing	4-1
4.1.1	Approach.....	4-2
4.1.2	Methodology.....	4-2
4.2	Wetlands and Other Waters of the U. S.	4-9
4.2.1	Regulatory Background	4-9
4.2.2	Jurisdictional Determination.....	4-10
4.2.3	Results.....	4-12
4.3	Habitat Evaluation Procedures (HEP).....	4-14
4.3.1	Approach.....	4-16
4.3.2	Study Area and Methods.....	4-16
4.3.3	Cover Type Delineation.....	4-17
4.3.4	Evaluation Species	4-18
4.3.5	Species Descriptions and Habitat Requirements	4-18
4.3.6	Cover Type Descriptions	4-23
4.3.7	Baseline Habitat Suitability Indices.....	4-37
4.3.8	Baseline Habitat Units	4-38
4.3.9	Future Habitat Units.....	4-39
	References.....	4-50

		Page
	FIGURES	
Figure 4-1.	Schematic of Spatial Database Development	4-3
Figure 4-2.	Waters of the U.S. Within the Normal Pool.....	after page 4-12
Figure 4-3.	1994 Conditions in the Lower Pool Area (topographic map)	after page 4-12
Figure 4-4.	1994 Conditions in the Lower Pool Area (aerial imagery)	after page 4-12
Figure 4-5.	2001 Conditions in the Lower Pool Area (topographic map)	after page 4-12
Figure 4-6.	2001 Conditions in the Lower Pool Area (aerial imagery)	after page 4-12
Figure 4-7.	Location map of HEP study areas.....	after page 4-16
Figure 4-8.	HEP Sampling Site Locations Shown on Cover Type Map.	after page 4-17
Figure 4-9.	HEP Sampling Area 1 on Color IR Aerial Photography.....	after page 4-38
Figure 4-10.	HEP Sampling Area 2 on Color IR Aerial Photography.....	after page 4-38
Figure 4-11.	HEP Sampling Area 3 on Color IR Aerial Photography.....	after page 4-38
Figure 4-12.	HEP Sampling Area 4 on Color IR Aerial Photography.....	after page 4-38
Figure 4-13.	HEP Sampling Area 5 on Color IR Aerial Photography.....	after page 4-38
Figure 4-14.	HEP Sampling Area 6 on Color IR Aerial Photography.....	after page 4-38
Figure 4-15.	HEP Sampling Area 7 on Color IR Aerial Photography.....	after page 4-38
Figure 4-16.	HEP Sampling Area 8 on Color IR Aerial Photography.....	after page 4-38
Figure 4-17.	HEP Sampling Area 9 on Color IR Aerial Photography.....	after page 4-38
Figure 4-18.	HEP Sampling Area 10 on Color IR Aerial Photography.....	after page 4-38
Figure 4-19.	HEP Sampling Area 13 on Color IR Aerial Photography.....	after page 4-38
Figure 4-20.	HEP Sampling Area 14 on Color IR Aerial Photography.....	after page 4-38

TABLE OF CONTENTS (continued)

TABLES	Page
Table 4-1. Area and Types of Waters of the U.S. Affected by the Proposed Lake Eastex	4-13
Table 4-2. Vegetation Cover in the Lower Pool Area Before and After Disturbance	4-13
Table 4-3. Habitat Variable Measurements at Deciduous Forested Wetland Sites	4-24
Table 4-4. Habitat Variable Measurements at Deciduous Upland Forest Sites	4-26
Table 4-5. Habitat Variable Measurements at Shrubland Sites	4-28
Table 4-6. Habitat Variable Measurements at Shrub Wetland Sites	4-30
Table 4-7. Habitat Variable Measurements at Grassland Sites	4-32
Table 4-8. Habitat Variable Measurements at Herbaceous Wetland Sites	4-34
Table 4-9. Habitat Variable Measurements at Riverine Sites	4-36
Table 4-10. Habitat Suitability Indices by Cover Type	4-38
Table 4-11. Baseline Habitat Units by Cover Type	4-38
Table 4-12. Predicted Changes in Cover Types Acreages without Lake Eastex	4-40
Table 4-13. Deciduous Forested Wetland Form C - Calculation of Average Annual Habitat Units	4-42
Table 4-14. Shrub Wetland Form C - Calculation of Average Annual Habitat Units	4-43
Table 4-15. Herbaceous Wetland Form C - Calculation of Average Annual Habitat Units	4-44
Table 4-16. Upland Forest Form C - Calculation of Average Annual Habitat Units	4-45
Table 4-17. Shrub Upland Form C - Calculation of Average Annual Habitat Units	4-46
Table 4-18. Grassland Form C - Calculation of Average Annual Habitat Units	4-47
Table 4-19. Riverine Form C - Calculation of Average Annual Habitat Units	4-48
Table 4-20. Net Impacts of Lake Eastex Project on Wildlife Habitat (AAHU)	4-48

4.0 ASSESSMENT OF WETLAND AND TERRESTRIAL HABITAT

4.1 Remote Sensing

Remote sensing techniques were used to update the classifications and areal extent of vegetation cover types that would be affected by the proposed Lake Eastex project. As in previous studies, the current investigation focused on the direct impact areas of Lake Eastex, including the conservation pool and dam construction areas.

In order to complete either the Habitat Evaluation Procedures (HEP) or wetland delineation tasks of this study, a comprehensive database that included the types, locations, and acreage of vegetation in the study area was required. This database was developed using previous studies, maps, written descriptions, and remote sensing data. ESRI™ ArcView and ArcInfo Geographic Information Systems (GIS) were used to compile and analyze numeric and narrative data as well as raster and vector data sources such as aerial photography, digital elevation models, digital orthophoto quarter quadrangles (DOQQs), topography, soil data, previous studies, field observations, and road maps. Current aerial imagery was acquired, and field observations were collected and incorporated into the database to identify temporal changes in vegetation patterns. The resulting geospatial database was used to develop numeric data sets for further analysis as well as maps to illustrate land cover types necessary for the completion of HEP and wetland analyses.

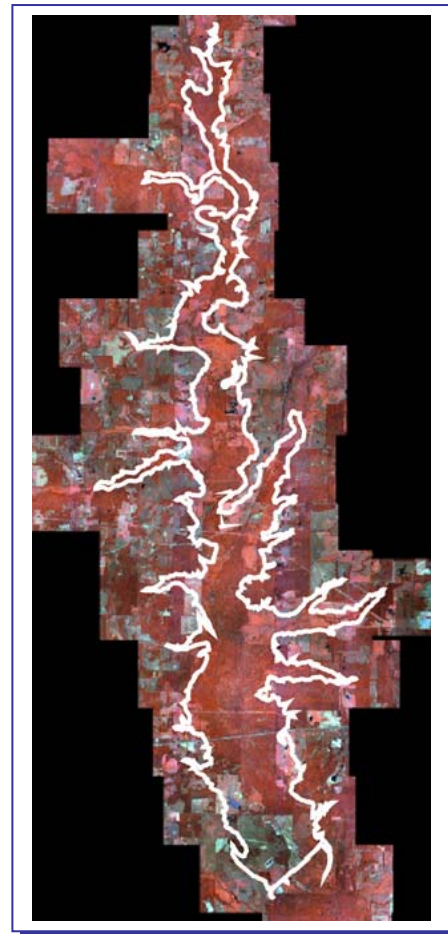

The following paragraphs describe the resources and methodology used to develop the database, as well as the applicability of the database in mapping activities.

4.1.1 Approach

In order to meet the data requirements for HEP and wetland tasks of the planning study, several informational components were combined or overlaid in a GIS platform. Figure 4-1 illustrates the general approach used in developing the geospatial database.

To accurately identify existing vegetative cover, new digital color infrared (IR) photography was collected for the planning study. Automated unsupervised digitizing of the color IR image was conducted to develop the first level of land cover classifications. Thirty separate classes were identified using this procedure (Level 1).

In a separate procedure, the original color infrared (IR) image was classified using heads up digitizing (manual interpretation of cover type boundaries). This image was combined with the Level 1 image and ground truthing data to produce the second level of vegetation cover classifications. Five separate classes of land cover were identified at this level (Level 2).

The final land cover classification (Level 3) was developed by combining several layers of existing information with recent field observations. Level 2 classifications were refined based on hydric soil identifications, wetland delineations presented by Hicks (1994b), stream locations mapped on USGS quadrangle maps, and observations documented during HEP and wetland delineation field activities conducted during the current study. Points within mapped cover types were verified through field observations.

4.1.2 Methodology

Existing aerial imagery was updated using aerial digital color IR. Classification of land cover and vegetation was performed using automated and visual/manual methods. Three steps, described in the following sections were used to determine final vegetative land cover classifications.

Aerial Imagery

Aerial imagery was the key component of the spatial database developed for this study. Considerations used in selecting a format for new aerial imagery included availability, quality and potential distortions, and ease of incorporating into a geospatial system.

Figure 4-1. Schematic of Spatial Database Development

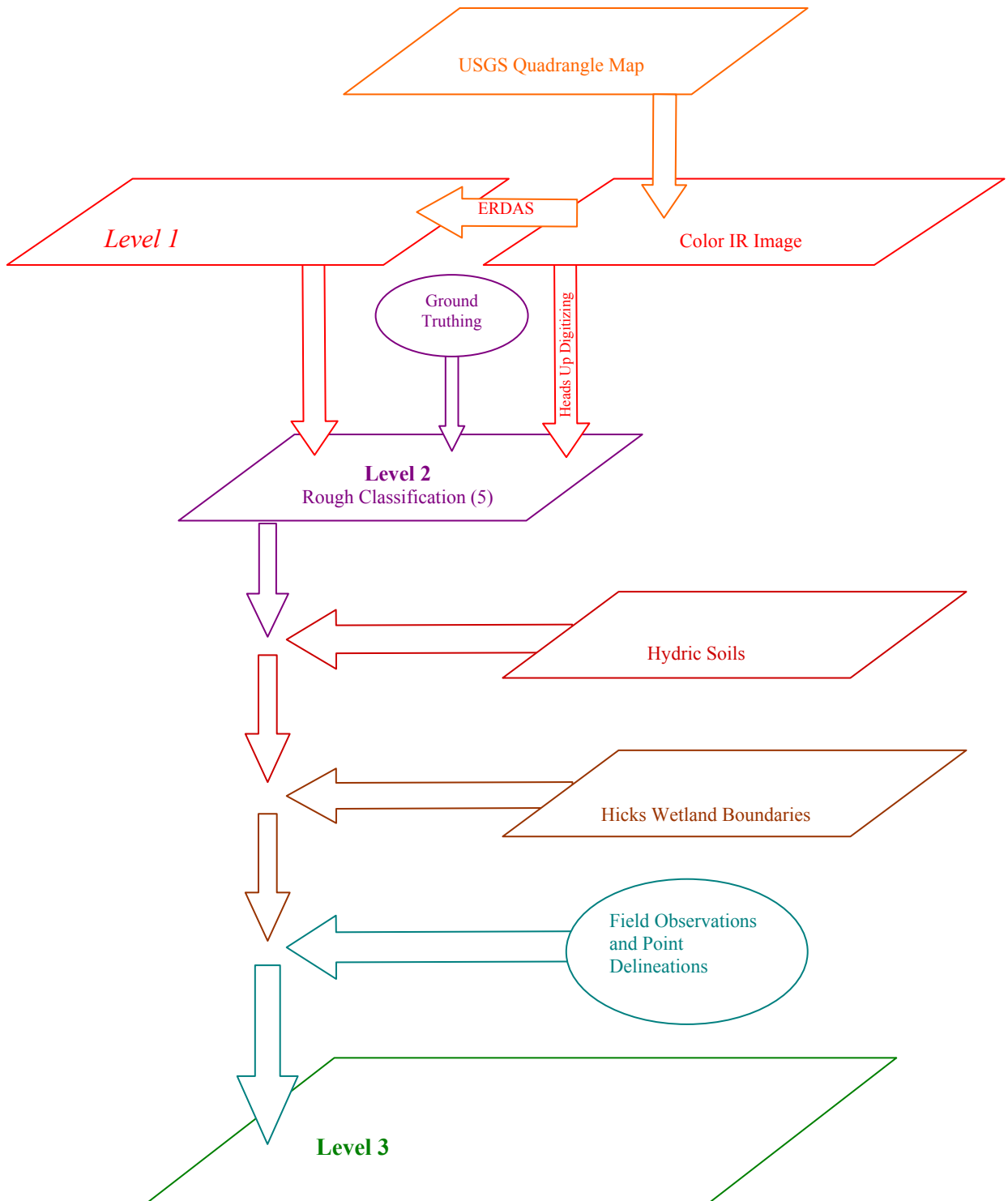

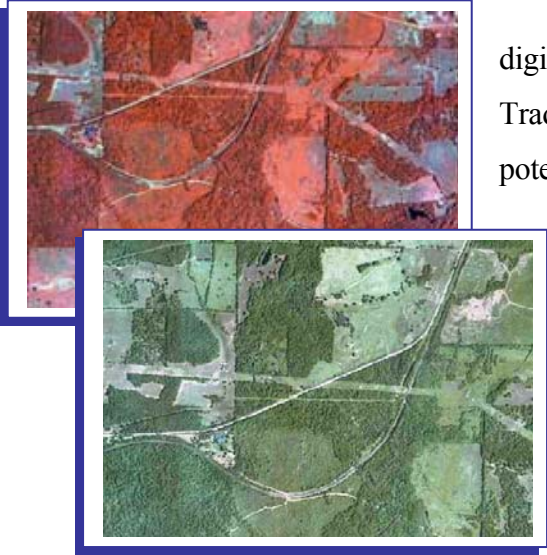

Traditional aerial photography, satellite imagery, and digital aerial photography were considered for this study. Traditional aerial photography was not used because of the potential for lens and camera tilt distortions, large number of images required to cover the study area, and because traditional prints are difficult to georeference and incorporate into a GIS. Satellite imagery was also considered because of its uniform spectral characteristics across the entire image and the ability to cover a larger area in a single image. Satellite imagery, however, was not available at the resolution desired for this study and was not available in stereo imagery. Also, the timing of imaging activities needed to avoid natural interferences such as cloud cover or time of day was not possible with satellite imagery.

Digital aerial photography was chosen for the study because of greater flexibility in collection times (daytime, seasonality, days with low cloud cover) and greater possible resolution. Digital aerial imagery can also be orthorectified (lens distortions removed), georeferenced (made to fit the correct place on the earth), and easily incorporated into a GIS. Color infrared photography was chosen because of the potential to detect vegetation characteristics.

Digital aerial color IR photography (2-foot pixel resolution) of the Lake Eastex conservation pool area was collected on August 4, 2001 by EMERGE™. A mosaic of the reservoir site was produced by compiling the individual images, removing lens distortions, and radiometrically enhancing the image to reduce the appearance of seams between the tiles. The mosaic image was georeferenced using the image processing software EMERGE™ to the UTM zone 14 NAD 27 coordinate system. Color enhancement and processing were performed using ERDAS Imagine® 8.5 software so that the color infrared image could appear in *pseudo color*, a color scheme more readily recognized as true color to the human eye. Color enhancement retains the spectral quality of the image while aiding researchers in the visual identification of vegetation types.

Classification

Both automated and manual processes were used to extract cross sections of information from the GIS database that described and illustrated land cover types. As described in the following paragraphs, classifications became progressively more detailed through the three-step process. Level 1 was developed using automated, or “unsupervised” techniques, while Levels 2 and 3 required visual verification and manual handling of data layers.

Level 1 - Unsupervised Classification

ERDAS Imagine® 8.5 image processing software was used to produce an unsupervised, or automated, classification of the tiled mosaic image. The software classified each 2-foot pixel in the mosaic into one of 30 distinct classes.



Level 2 – Rough Classification

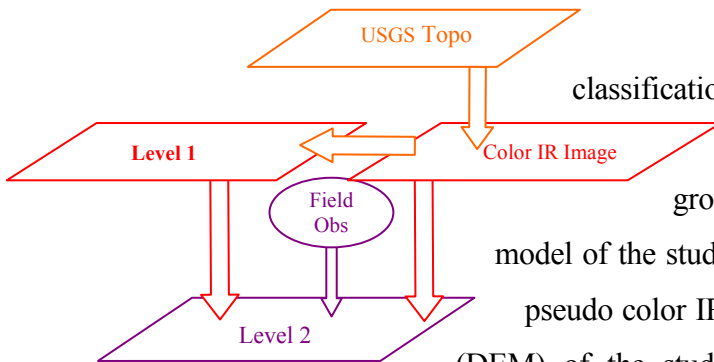

To arrive at the next level of classification, Level 1 imagery was combined with digital elevation imagery and ground truthing data. A three-dimensional model of the study area was developed by combining the pseudo color IR image with the digital elevation model (DEM) of the study area. Enhancement of the vertical

elevation within the 3-D image was used to detect subtle vertical changes in topography and vegetative cover. By using the stereo viewing capability made possible by a 60 percent end lap of the original imagery, viewing the stereo image expedited the manual delineation of cover types.

By visually comparing the Level 1 image, color IR image, and stereo imagery within the GIS program, the 30 classes in the Level 1 image were manually grouped into classes of similar cover types. This grouping process yielded four classifications of land cover - water, forest,

field, and urban. Field visits at 41 sites provided the ground truthing necessary to verify classifications and distinguish between ambiguous areas identified from the imagery. For example, classifications were modified to reflect actual ground conditions in areas where imagery indicated a mixture of forest and shrub, but field observations confirmed the area consisted of thinned forest. Locations of ground truthed sites were documented using GPS. Data collected during field visits were recorded on standardized field data sheets (Volume II) and photographs.

Although developed areas were identified in previous classifications, they were represented only by single residences or small groupings of houses, and by linear tracts developed for transportation uses. Overall, the relative extent of “urban” land cover represented by residences was not significant enough to justify a separate class and was grouped into the next closest adjacent class. A new category of “transportation” was created for major highways and railroads. The Level 2 classifications included water, forest, shrub, field, and transportation.

Level 3 – Final Classification

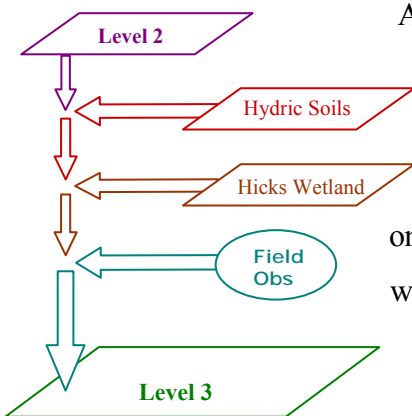

According to the U.S. Army Corps of Engineers (USACE), wetland areas are classified as such because of vegetative cover types, the presence of hydric soils, and hydrologic characteristics (USACE 1987). Level 1 and Level 2 classifications of land cover were based on imagery and visual observations. In order to meet the data needs for wetland identification and delineation, Level 3 classifications were developed by incorporating soil and hydrologic information.

Hydric soils in the Lake Eastex area were identified by integrating USDA soil survey data (U.S. Soil Conservation Service 1985) to the GIS database. Maps of the study area contained in the Smith County Soil Survey data were available in electronic format from the USDA web site (NRCS 2002) and were directly uploaded to the database. Soil survey data for Cherokee County, however, were converted from traditional maps

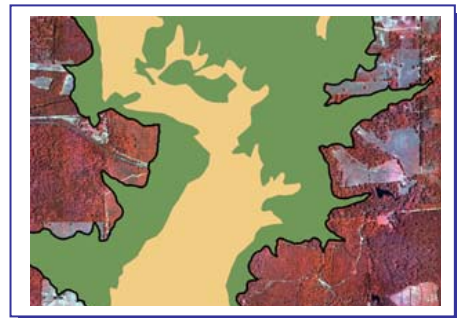

contained in the Cherokee County Texas Soil Survey (March 1959). The maps were scanned then georeferenced using ERDAS Imagine[®] 8.5 software and the ArcInfo extension ArcScan. Soil boundaries were then digitized. As soil types were delineated, the respective soil classification data were entered into the database.

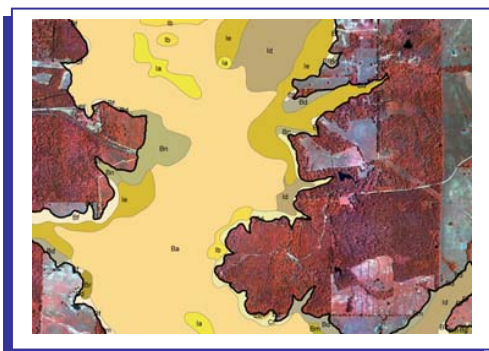

In addition to the previous Lake Eastex Water Supply Planning Study (LAN 1991) that evaluated water supply and environmental issues, a study was performed by Hicks and Company to delineate wetlands in the project area (Hicks 1994b). The purpose of the Hicks study was to identify waters of the U.S., including wetlands. The Hicks study used delineation procedures in accordance with

the manual (USACE 1987) as well as remote sensing using traditional black and white and color infrared photography collected in 1993.

Wetland delineation maps produced by Hicks were converted to digital format and georeferenced using Texas Department of Transportation (TxDOT) digital road files acquired from the Texas Natural Resources Information System (TNRIS) web site (TNRIS 2002). Wetland boundaries were then digitized and overlaid on the Level 2 land cover classifications described above. The data were used along with ground truthing to delineate wetland boundaries. Data from the Hicks wetland boundaries were added to the GIS database.

Wetland delineation and cover type determinations were made during the course of this study to improve the accuracy of the database. Additional data were collected in conjunction with HEP field measurements, including wetland delineation and cover type classification. Streams and other water bodies were digitized from USGS topographic maps and added to the GIS database. Based on field observations, intermittent streams were buffered using a 10-foot corridor and perennial streams were buffered using a 30-foot corridor to reflect areas of stream habitat.

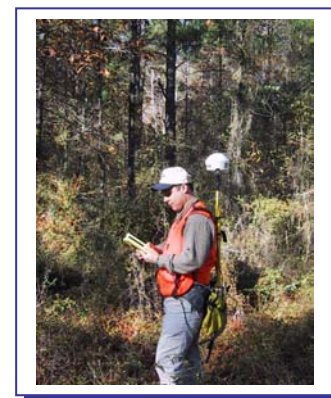

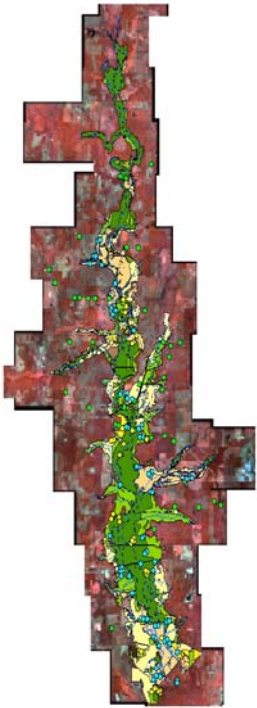

Level 3 classifications were derived by the integration of Level 2 imagery with field observations and soil, wetland, and hydrologic information. Level 3 land cover classifications include streams and open water; herbaceous, shrub, and forested wetlands; herbaceous, shrub, and forested uplands; urban; and highways and railroads.

The geospatial database developed for the Lake Eastex planning studies was used to produce numeric data sets and maps for use in the HEP modeling and analyses and delineation of waters of the U.S. Detailed discussions of wetlands and HEP analyses in the Lake Eastex project area are presented in report Sections 4.2 and 4.3, respectively.

4.2 Wetlands and Other Waters of the U. S.

“Waters of the U.S.”
 33 CFR, Part 328

include (among others):

- wetlands -streams
- natural ponds -rivers
- wet meadows -lakes

The purpose of this study was to delineate wetlands and other waters of the U.S. within the proposed Lake Eastex pool area, map these waters, and quantify them by type. The study included an analysis of impacts on waters due to construction activities near the dam as well as total impacts due to construction and inundation up to the normal pool elevation (315 ft NGVD).

4.2.1 Regulatory Background

Initial planning for the proposed Lake Eastex was begun by ANRA as early as 1978. Their activities led to the issuance of a state water right permit by the Texas Water Commission in 1985 to develop the reservoir at a location on Mud Creek in Cherokee and Smith Counties. The permit has subsequently been amended to require construction by 2011. The water right permit allows ANRA to divert 85,507 acre feet of water from the proposed reservoir for municipal and industrial uses each year.

Several studies were conducted in the following years in order to investigate the potential economic, environmental, and other impacts due to the project. In 1991 Lockwood, Andrews, and Newnam, Inc. (LAN) published the *Lake Eastex Regional Water Supply Planning Study*, a comprehensive study of the proposed reservoir project. The report included analyses of engineering, financial, and environmental issues. In 1994, Hicks and Company prepared a draft report of investigations related to potential impacts on wetlands and other waters of the U.S., including identification and delineation of waters of the U.S., including wetlands. Review of recent aerial photography of the reservoir pool area revealed that potentially significant changes in wetland cover types may have occurred due to logging, clearing for pasture and cropland, and stream alteration in the years since the Hicks and Company (1994b) study.

Lake Eastex Timeline

- 1978 Initial planning activities begun by ANRA
- 1985 Water right permit issued by Texas Water Commission
- 1991 Lockwood, Andrews & Newnam report
- 1994 Hicks and Company wetland delineation report
- 2000 ANRA submitted application for 404 Permit
- 2001 Permit extended to 2011
- 2002 State Water Plan includes Lake Eastex as a recommended strategy
- 2003 Freese and Nichols Planning Studies report

Lake Eastex became part of the state water plan (TWDB 2002) when the TWDB adopted the East Texas planning region's plan that included the Lake Eastex project as a "recommended strategy" for supplying water to meet future demands of the planning region.

In an effort to meet regulatory requirements necessary to develop the reservoir, ANRA submitted an application to the USACE in October 2000 for a federal permit, in accordance with Section 404 of the Clean Water Act. Issuance of the 404 permit requires a study to identify and delineate wetlands and other waters of the U.S. that would be impacted by the proposed project. The current study conducted by Freese and Nichols, Inc. (FNI) serves to verify and update previous studies by LAN and Hicks and to provide a baseline from which to evaluate potential impacts to waters of the U.S. Mitigation of wetlands and other waters of the U.S. associated with the Lake Eastex project are discussed in Chapter 6 of this report.

4.2.2 Jurisdictional Determination

Jurisdictional Determination

A report describing the portions of the project area that may be regulated by the Corps of Engineers under Section 404 of the Clean Water Act.

Several sources of data and field reconnaissance were used to develop the preliminary jurisdictional determination. The study was based on a foundation of existing work that was evaluated and updated to reflect existing conditions. Field reconnaissance, remote sensing, and GIS-based analyses were used to develop a comprehensive database of vegetation, hydrologic, and soil characteristics and define wetland boundaries.

Previous Studies and Existing Information

Previous wetland delineations of the Lake Eastex site, conducted by Hicks and Company (1994a and 1994b), formed the starting place for the current study of wetland and other waters of the U.S. Hicks' work was conducted in accordance with the USACE's (1987) Wetland Delineation Manual and under consultation with the Fort Worth District Regulatory staff. Their reports consist of a project procedures manual (guidance plan) for wetland delineation and a draft report of Section 404 wetland delineation at the proposed Lake Eastex site. Both documents are presented in Volume II of this report.

Hydric soil mapping information was derived from the USDA Soil Conservation Service soil surveys for Cherokee and Smith Counties. Digital U.S. Geological Survey

topographic maps provided both topographic and hydrologic features that were incorporated into the GIS database.

Remote Sensing and Data Analysis

Current aerial photography and other geospatial information were used to identify land use changes that had taken place at the project site since the Hicks reports were published. A detailed discussion on remote sensing and the development of the GIS database is located in Section 4.1 of this chapter.

Recent aerial photography (August 2001) was used as a foundation for the analysis of additional data layers within the GIS database. The aerial photography was used to delineate vegetation cover types, then overlaid with Hicks' wetland boundaries, hydric soils boundaries, and hydrologic features. The resulting database was used to map wetland field data from the Hicks' report and identify areas where current field reconnaissance was needed. Wetland delineation field data sheets recorded by FNI are included in Appendix III of this report.

Wetland boundaries from the Hicks report were generally accurate, but recent changes in land use required that some boundaries be adjusted. Wetland types identified in the study include forested, herbaceous, shrub-scrub, and hillside bog. Other waters of the U.S. were also identified and classified as open water, perennial stream, intermittent stream or new channel. Using field observations and hydrologic information from USGS topographic maps, average widths for jurisdictional streams were assumed to be 30 feet for perennial streams and 10 feet for intermittent streams. The areas were calculated for each type of wetland and other waters of the U.S. using ArcInfo GIS.

4.2.3 Results

Results presented in Figures 4-2a through 4-2g indicate that a total of 5,746 acres of waters of the U.S. would be impacted either by construction or inundation by the proposed Lake Eastex. Approximately 64 percent of these affected areas would be forested wetlands, 26 percent herbaceous wetlands, and 10 percent a combination of shrub-scrub wetlands, bogs, streams, and open water.

Figure 4-2a also illustrates the types of waters of the U.S. located in the 220 acre area directly impacted by construction and placement of fill material for the dam and spillway structures. Approximately 76 percent of the waters of the U.S. directly impacted by construction activities are herbaceous wetlands, 17 percent forested wetland, and 7 percent a combination of streams and open water.

Changes in land use that were detected through this study resulted in updates to various cover types as well as the inclusion of wetland areas not mapped in earlier reports. While some of the Lake Eastex site has been harvested for timber since the 1994 delineation, most of the approximately 10,000-acre site has sustained no disturbance that would appreciably alter hydrology or topography or change wetland boundaries. The exception to this statement is a roughly 1,000-acre area in the vicinity of the proposed dam where some forested areas have been cleared, Mud Creek has been channelized, and levees have been constructed that altered surface drainage and possibly dewatered some wetlands. Figures 4-3 and 4-4 illustrate the vegetation types in this area at the time of the Hicks report in 1994, and Figures 4-5 and 4-6 reflect conditions in 2001. As shown in Tables 4-1 and 4-2, the disturbance described above resulted in the creation of 25 acres of new channel and the conversion of approximately 264 acres of forested wetland to herbaceous wetland.

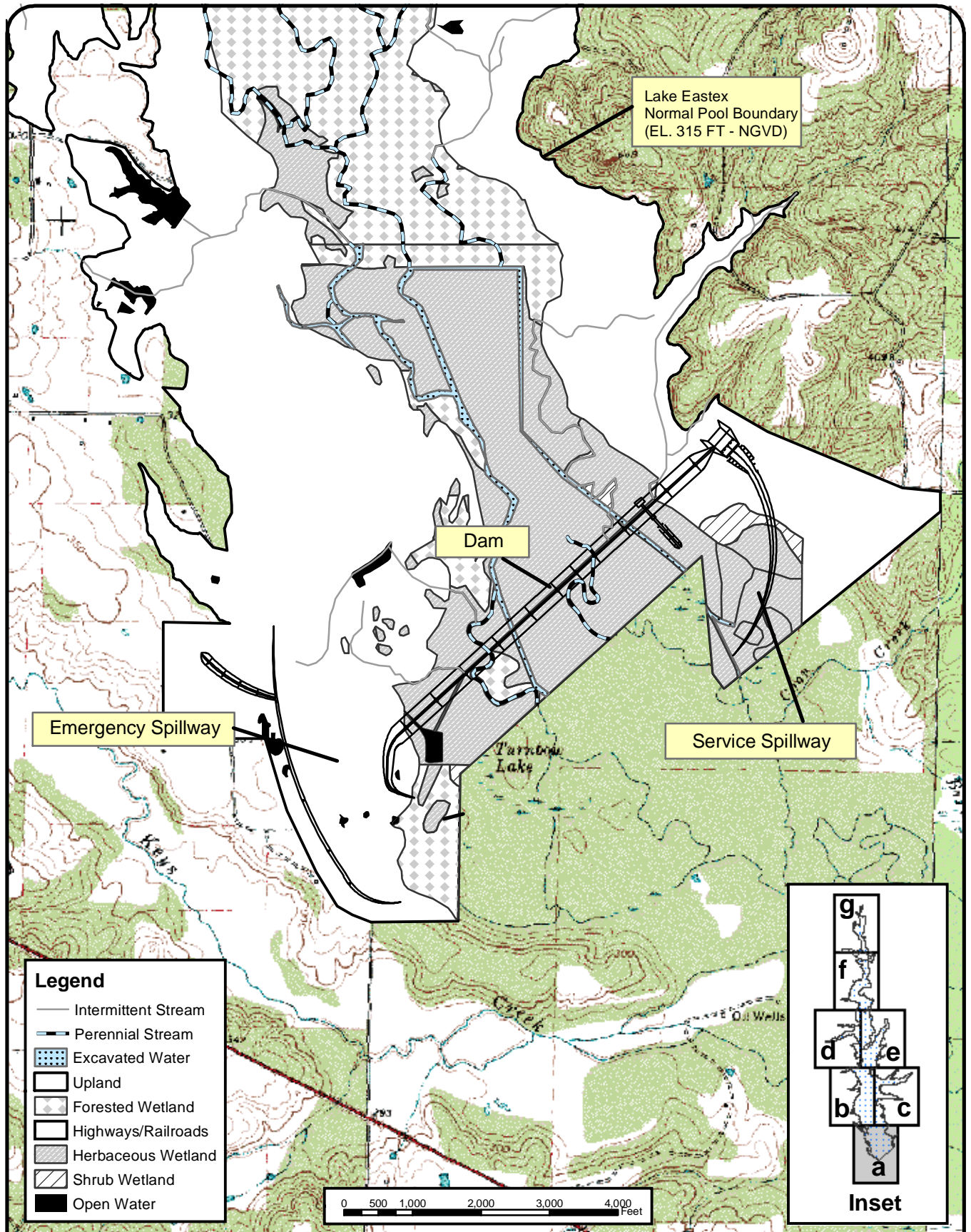

FREESE - NICHOLS
 4055 International Plaza Suite 200
 Fort Worth, Texas 76109-4895
 817-735-7300



**Angelina and Neches River Authority
 Proposed Lake Eastex**

**Waters of the U.S.
 Within the Normal Pool**

FN JOB NO	ANR01289
FILE	H:/8x11papermaps/Wetlands/1of7.mxd
DATE	February 13, 2003
SCALE	1:24,000
DESIGNED	RH
DRAFTED	BAR

4-2a

FIGURE

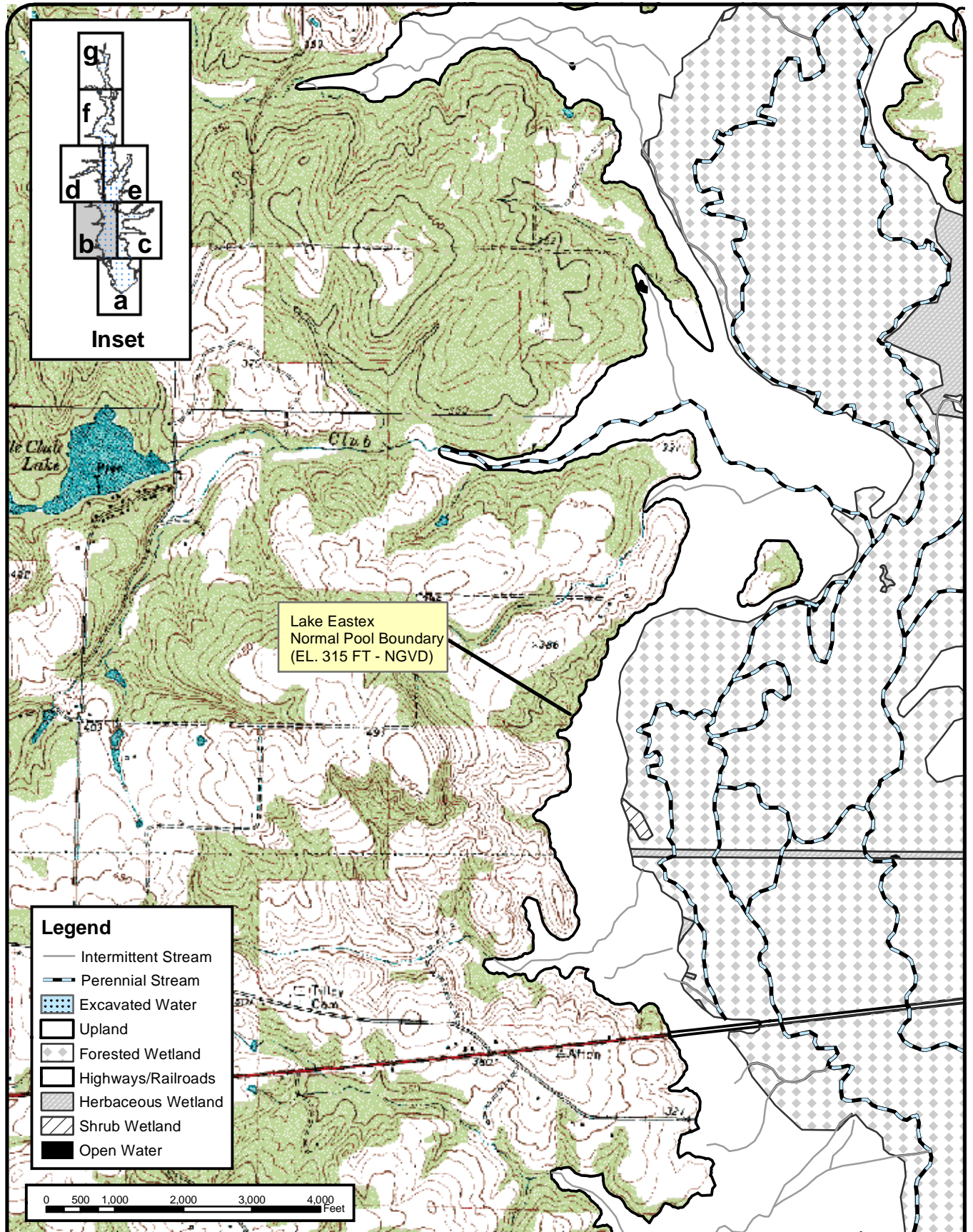

Legend

- Intermittent Stream
- Perennial Stream
- Excavated Water
- Upland
- Forested Wetland
- Highways/Railroads
- Herbaceous Wetland
- Shrub Wetland
- Open Water

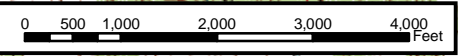

FREESE-NICHOLS
 4055 International Plaza Suite 200
 Fort Worth, Texas 76109-4895
 817-735-7300

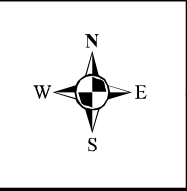

Angelina and Neches River Authority
Proposed Lake Eastex

Waters of the U.S.
Within the Normal Pool

FN JOB NO	ANR01289
FILE	H:/8x11papermaps/Wetlands/2of7.mxd
DATE	February 13, 2003
SCALE	1:24,000
DESIGNED	RH
DRAFTED	BAR

4-2b

FIGURE

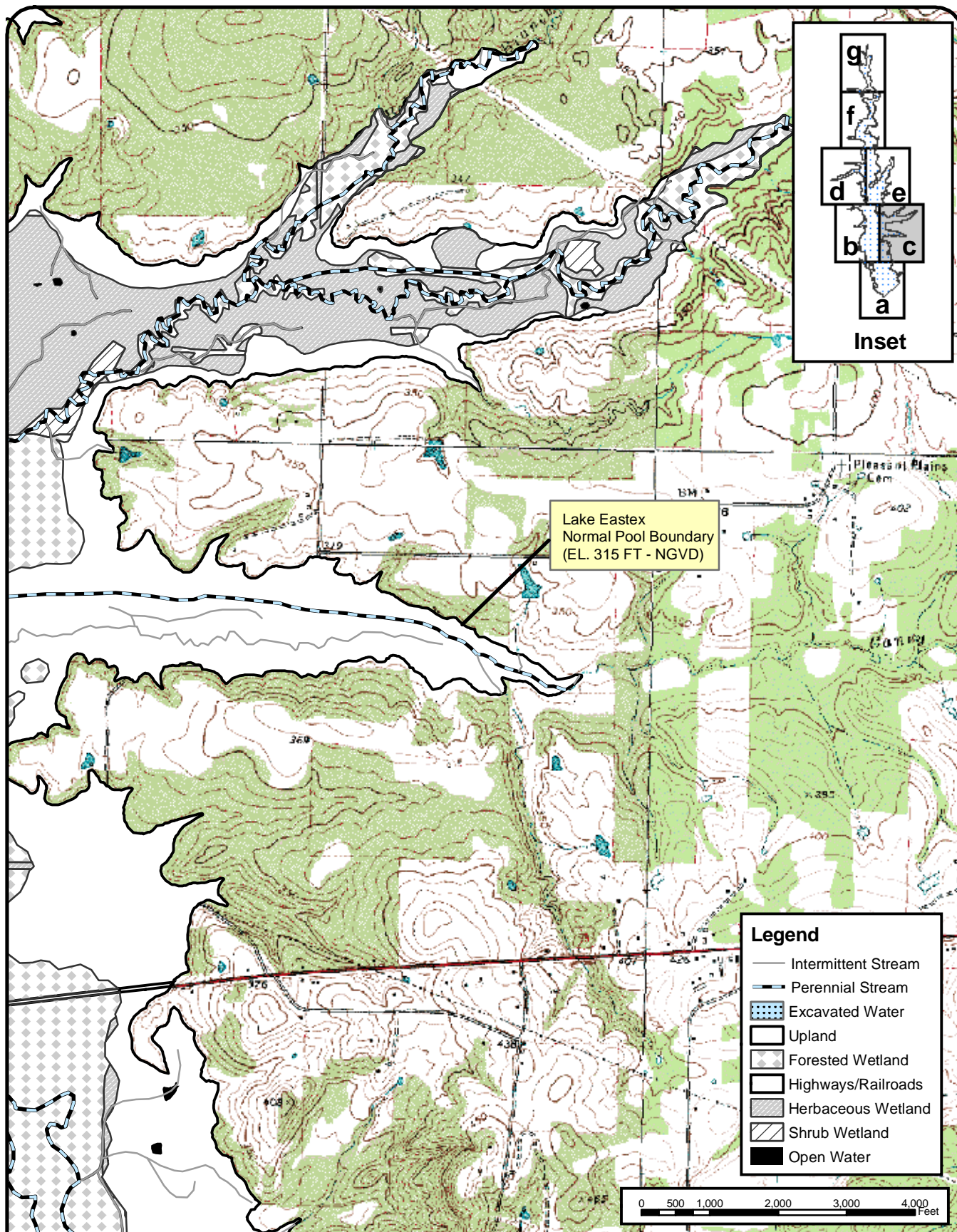

Lake Eastex
Normal Pool Boundary
(EL. 315 FT - NGVD)

- Legend**
- Intermittent Stream
 - Perennial Stream
 - Excavated Water
 - Upland
 - Forested Wetland
 - Highways/Railroads
 - Herbaceous Wetland
 - Shrub Wetland
 - Open Water

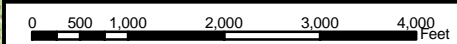

FREESE-NICHOLS
4055 International Plaza Suite 200
Fort Worth, Texas 76109-4895
817-735-7300



Angelina and Neches River Authority
Proposed Lake Eastex

Waters of the U.S.
Within the Normal Pool

FN JOB NO	ANR01289
FILE	H:\8x11 papermaps/ Wetlands\3of7.mxd
DATE	February 13, 2003
SCALE	1:24,000
DESIGNED	RH
DRAFTED	BAR

4-2c
FIGURE

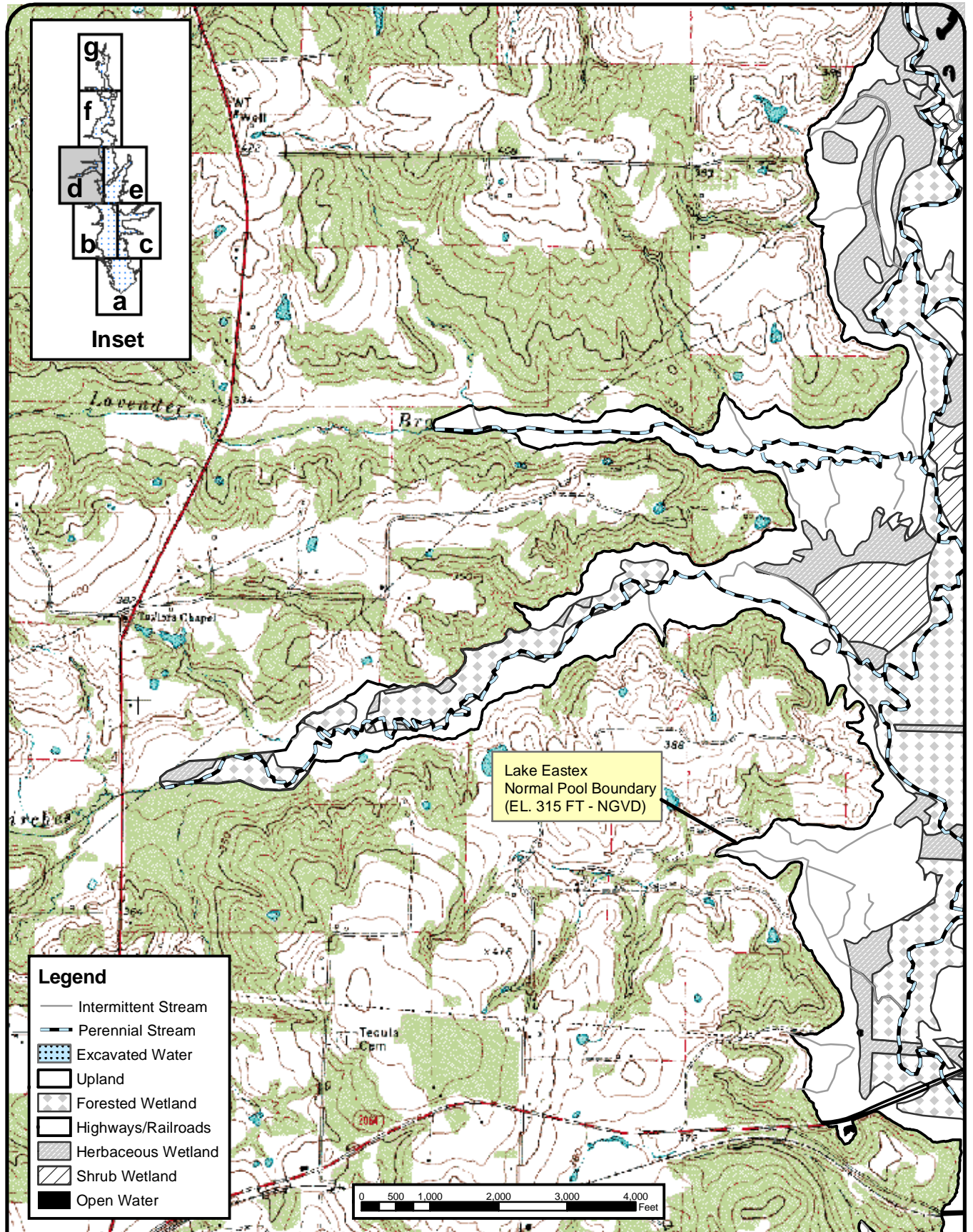

- Legend**
- Intermittent Stream
 - Perennial Stream
 - Excavated Water
 - Upland
 - Forested Wetland
 - Highways/Railroads
 - Herbaceous Wetland
 - Shrub Wetland
 - Open Water

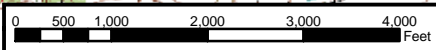

FREESE - NICHOLS
 4055 International Plaza Suite 200
 Fort Worth, Texas 76109-4895
 817-735-7300



**Angelina and Neches River Authority
 Proposed Lake Eastex**

**Waters of the U.S.
 Within the Normal Pool**

FN JOB NO	ANR01289
FILE	H:\8x11 papermaps/ Wetlands\4of7.mxd
DATE	February 13, 2003
SCALE	1:24,000
DESIGNED	RH
DRAFTED	BAR

**4-2d
 FIGURE**

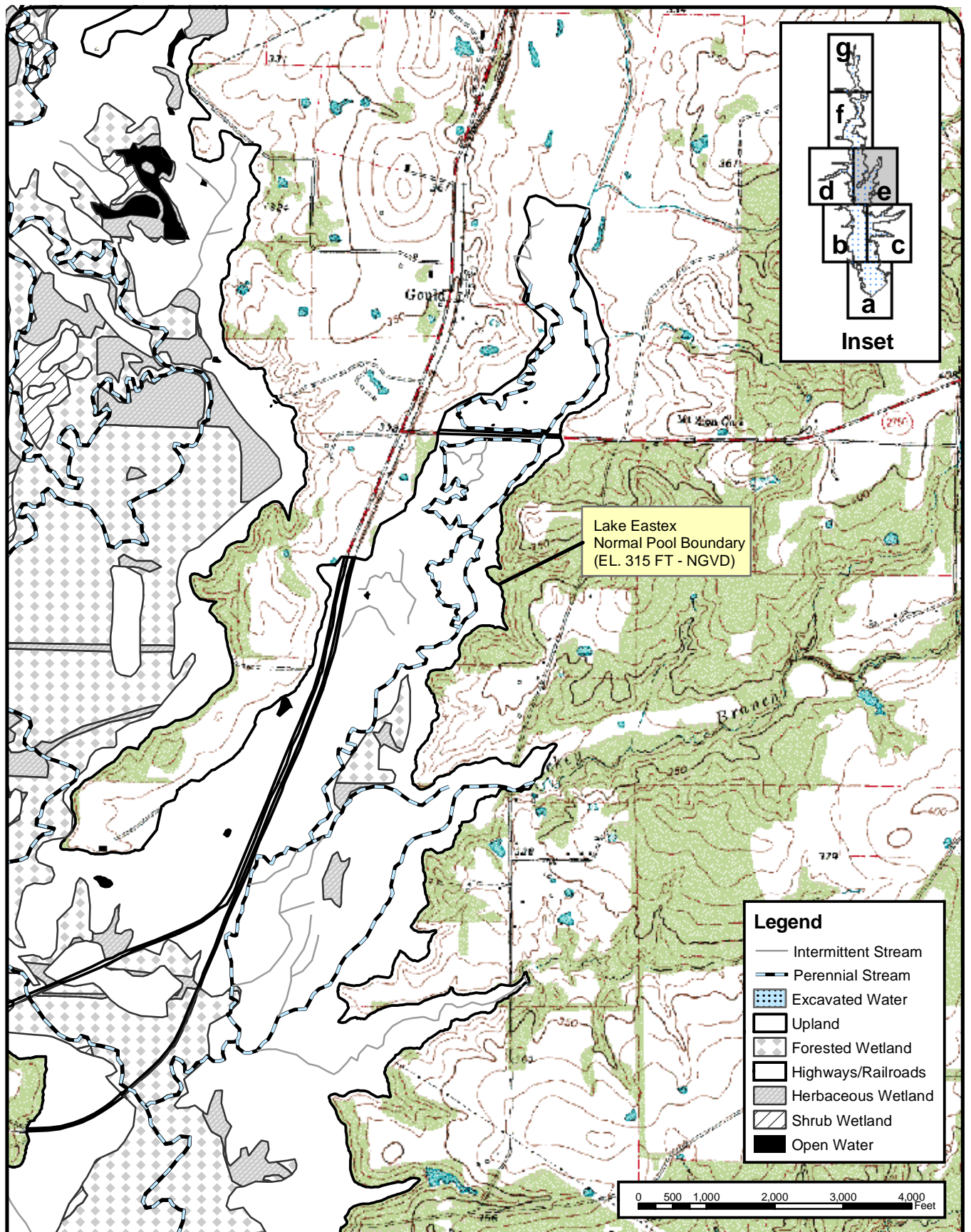

FREESE-NICHOLS
 4055 International Plaza Suite 200
 Fort Worth, Texas 76109-4895
 817-735-7300



**Angelina and Neches River Authority
 Proposed Lake Eastex**

**Waters of the U.S.
 Within the Normal Pool**

FN JOB NO	ANR01289
FILE	H:\8x11 papermaps/ Wetlands\5of7.mxd
DATE	February 13, 2003
SCALE	1:24,000
DESIGNED	RH
DRAFTED	BAR

4-2e

FIGURE

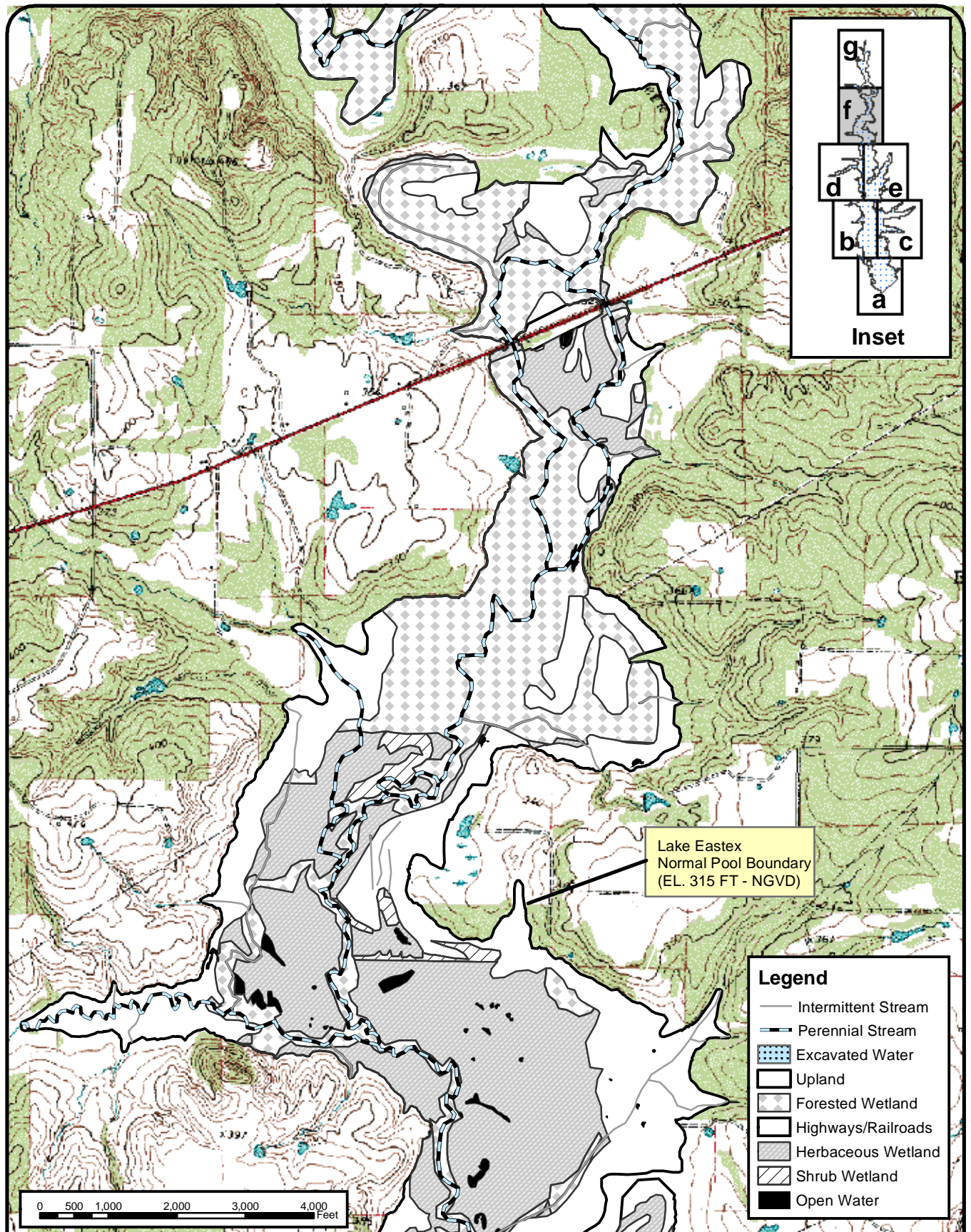

FREESE - NICHOLS
4055 International Plaza Suite 200
Fort Worth, Texas 76109-4895
817-735-7300



**Angelina and Neches River Authority
Proposed Lake Eastex**

**Waters of the U.S.
Within the Normal Pool**

FN JOB NO ANR01289
FILE H:/8x11papermaps/
Wetlands/6of7.mxd
DATE February 13, 2003
SCALE 1:24,000
DESIGNED RH
DRAFTED BAR

4-2f

FIGURE

- Legend**
- Intermittent Stream
 - Perennial Stream
 - ▒ Excavated Water
 - Upland
 - ▒ Forested Wetland
 - Highways/Railroads
 - ▒ Herbaceous Wetland
 - ▒ Shrub Wetland
 - Open Water

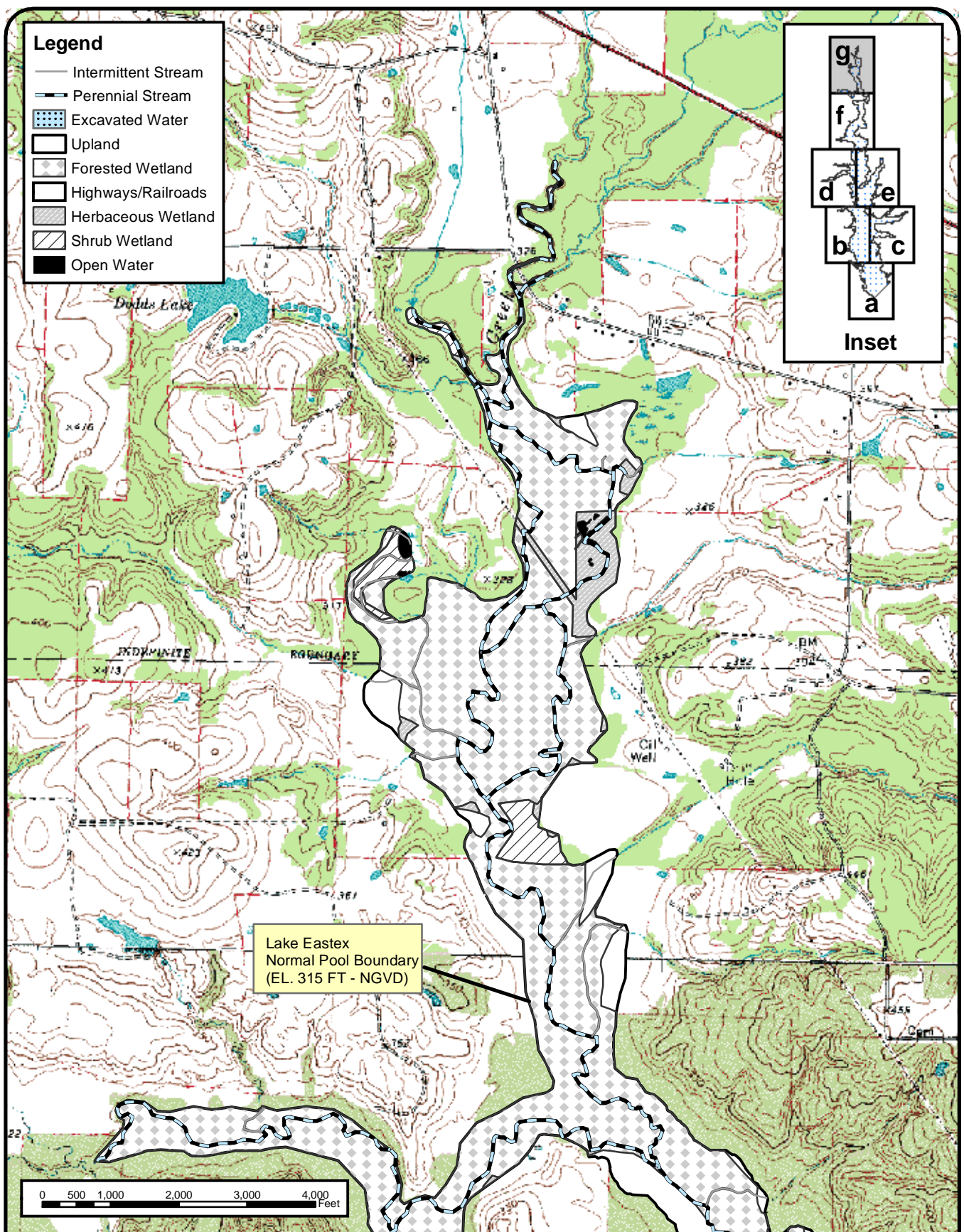
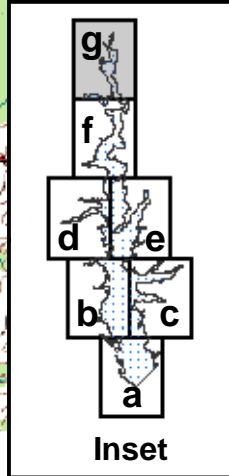

Lake Eastex
Normal Pool Boundary
(EL. 315 FT - NGVD)

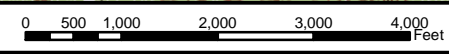

FREESE-NICHOLS
4055 International Plaza Suite 200
Fort Worth, Texas 76109-4895
817-735-7300



**Angelina and Neches River Authority
Proposed Lake Eastex**

**Waters of the U.S.
Within the Normal Pool**

FN JOB NO	ANR01289
FILE	H:/8x11papermaps/Wetlands/7of7.mxd
DATE	February 13, 2003
SCALE	1:24,000
DESIGNED	RH
DRAFTED	BAR

**4-2g
FIGURE**

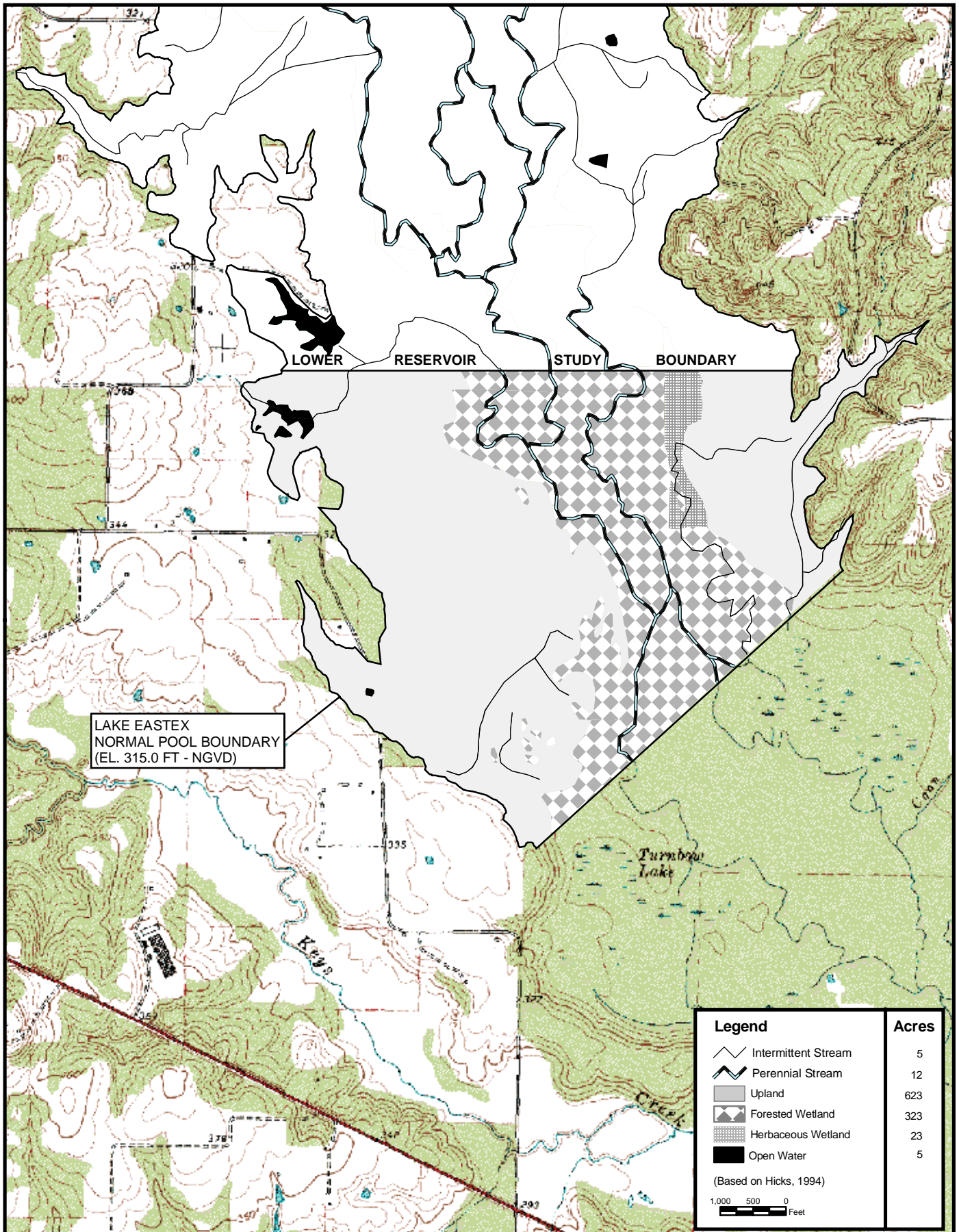

FFESE • NICHOLS
 4055 International Plaza Suite 200
 Fort Worth, Texas 76109 4895
 817 735 7300

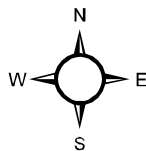

**Angelina and Neches River Authority
 Proposed Lake Eastex**

**1994 Conditions in the
 Lower Pool Area**

FN JOB NO	ANR01289
FILE	H:\8x11papermaps\BeforeDisturbance.mxd
DATE	August 27, 2002
SCALE	1:24,000
DESIGNED	SPW
DRAFTED	JAR

4-3

Figure

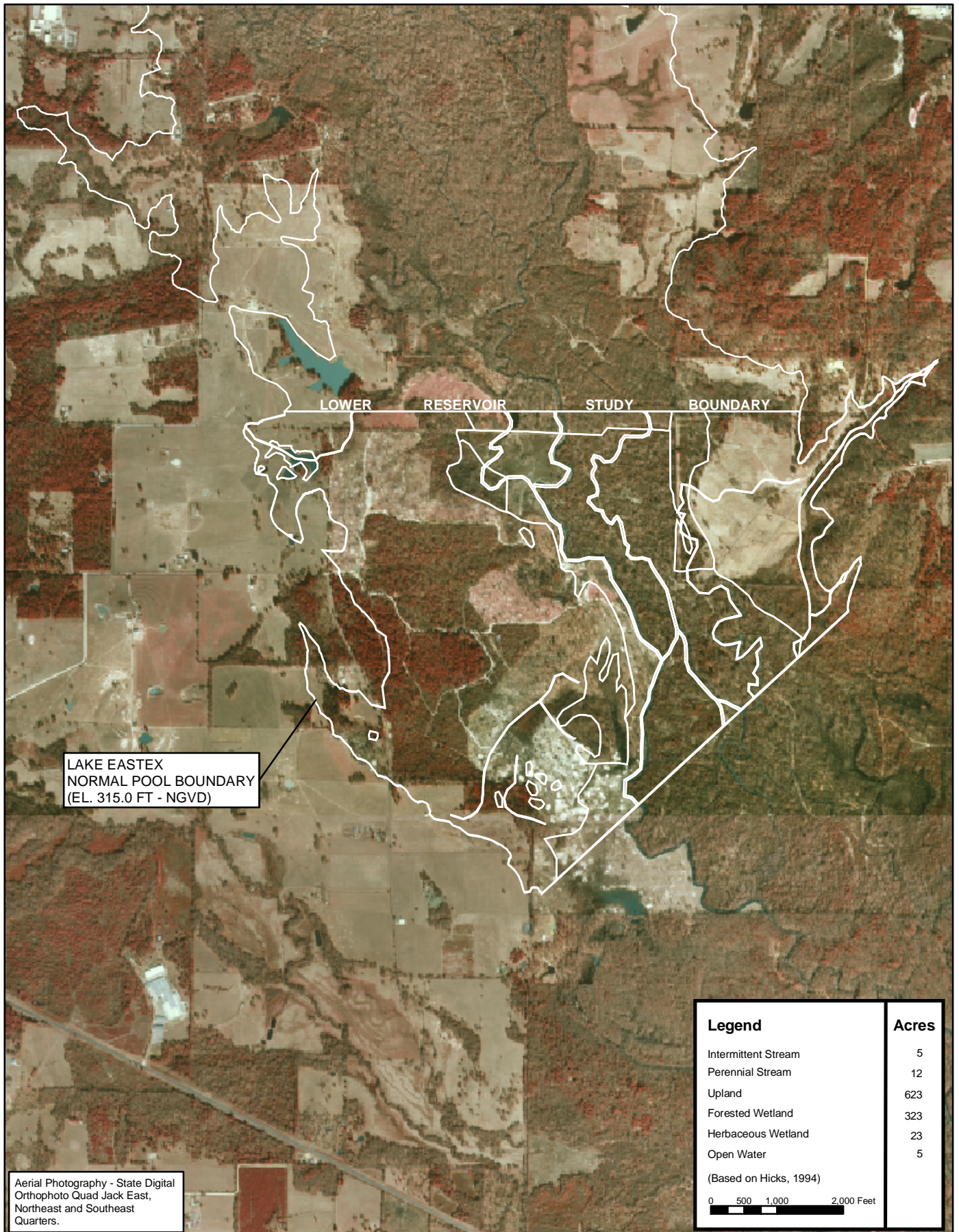

LAKE EASTEX
NORMAL POOL BOUNDARY
(EL. 315.0 FT - NGVD)

Aerial Photography - State Digital
Orthophoto Quad Jack East,
Northeast and Southeast
Quarters.

Legend	Acres
Intermittent Stream	5
Perennial Stream	12
Upland	623
Forested Wetland	323
Herbaceous Wetland	23
Open Water	5
(Based on Hicks, 1994)	
0 500 1,000 2,000 Feet	

FRFSE • NICHOLS
4055 International Plaza Suite 200
Fort Worth, Texas 76109 4895
817 735 7300

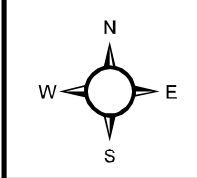

Angelina and Neches River Authority
Proposed Lake Eastex
1994 Conditions in the
Lower Pool Area

FN JOB NO	ANR01289
FILE	H:\x11\papermaps\BeforeDisturbanceAerial.mxd
DATE	August 27, 2002
SCALE	1:24,000
DESIGNED	SPW
DRAFTED	JAR

4-4
Figure

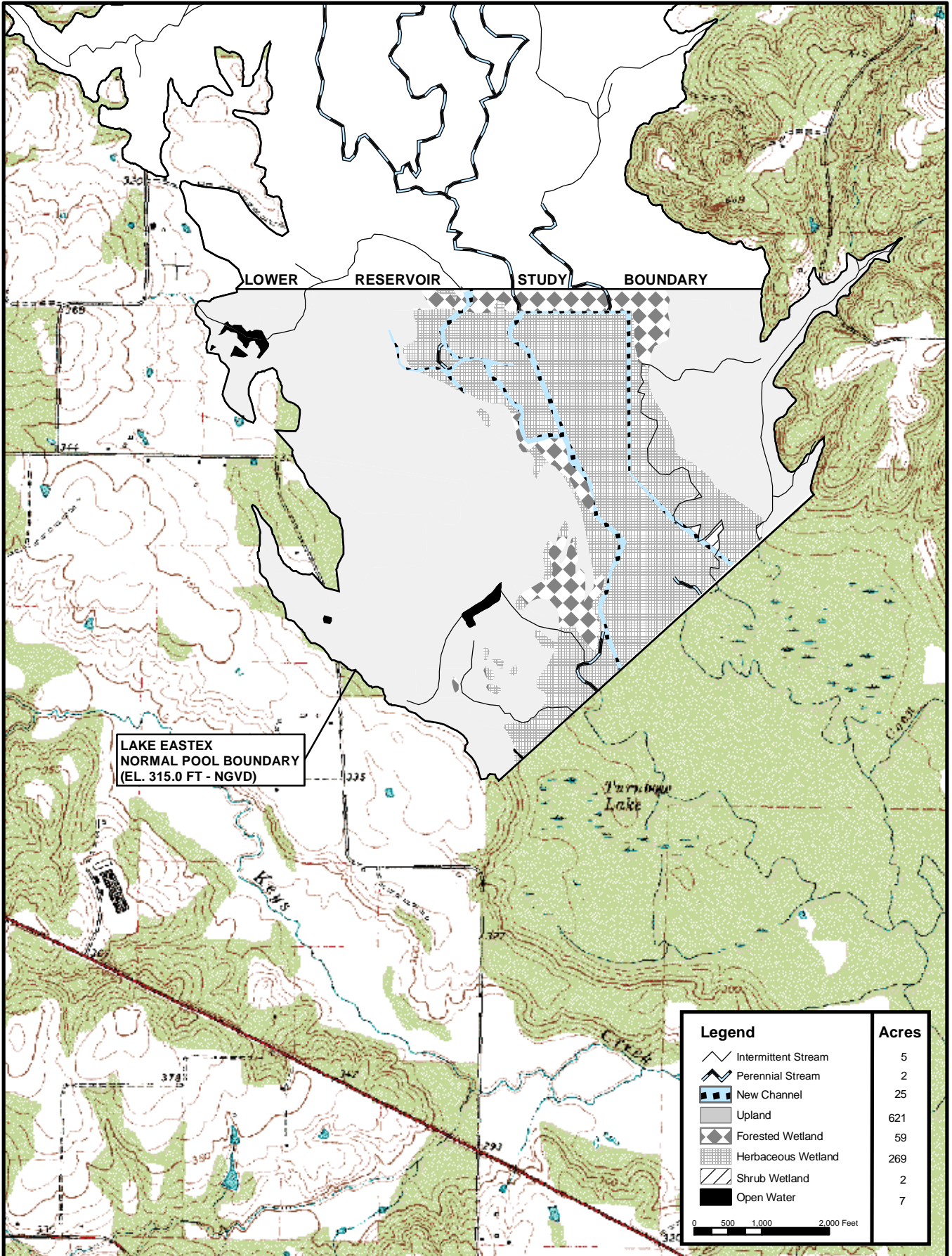

Aerial Photography - Flown August 2001 for Freese and Nichols Inc.

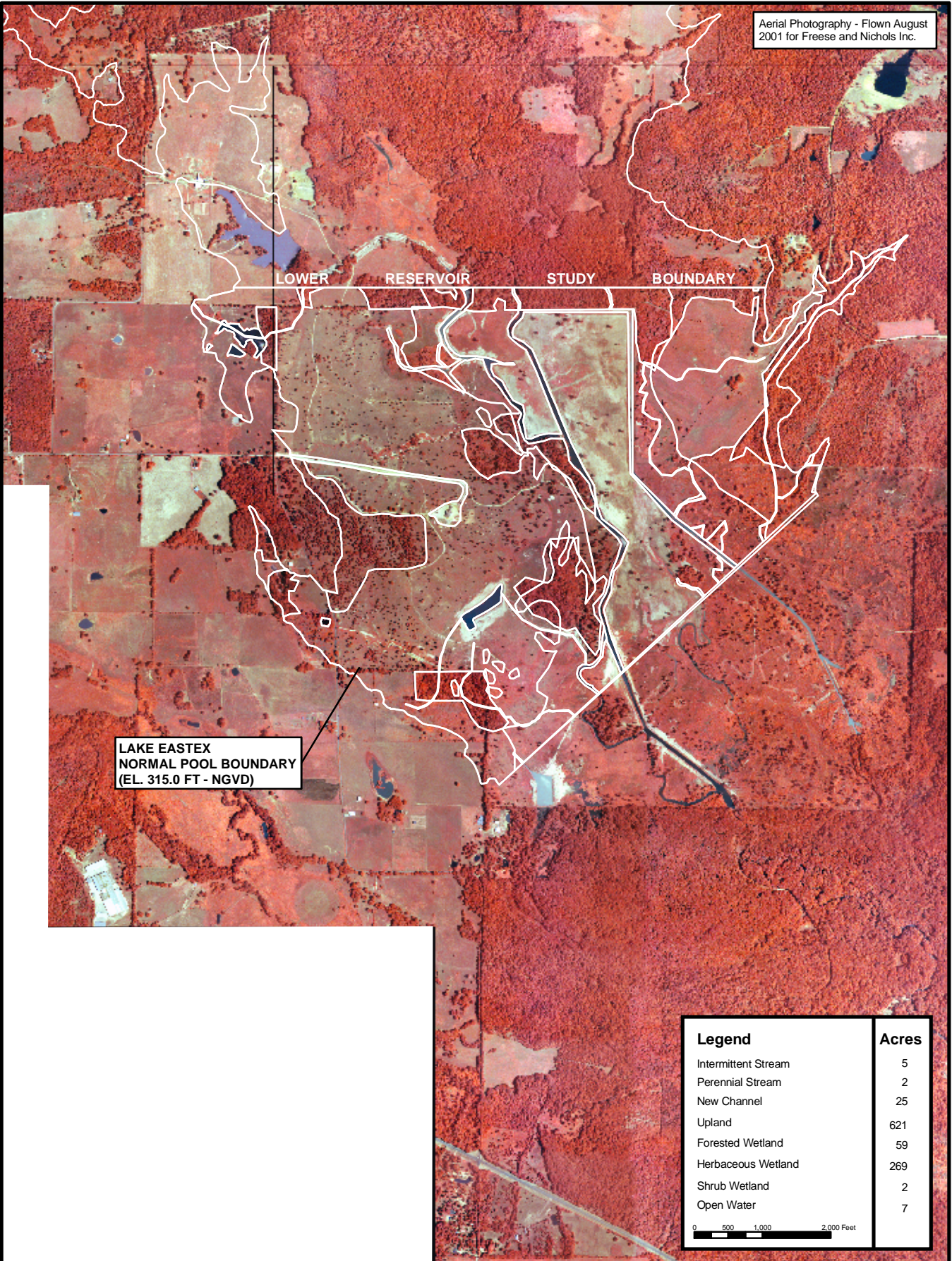

LAKE EASTEX
NORMAL POOL BOUNDARY
(EL. 315.0 FT - NGVD)

Legend	Acres
Intermittent Stream	5
Perennial Stream	2
New Channel	25
Upland	621
Forested Wetland	59
Herbaceous Wetland	269
Shrub Wetland	2
Open Water	7

0 500 1,000 2,000 Feet



FREESE • NICHOLS
4055 International Plaza Suite 200
Fort Worth, Texas 76109 4895
817 735 7300

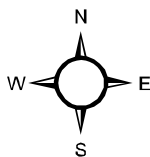

**Angelina and Neches River Authority
Proposed Lake Eastex**

**2001 Conditions in the
Lower Pool Area**

FN JOB NO	ANR01289
FILE	H:\8x11papermaps\AlterDisturbanceAerial.mxd
DATE	August 27, 2001
SCALE	1:24,000
DESIGNED	SPW
DRAFTED	JAR

4-6

Figure

Table 4-1. Area and Types of Waters of the U.S. Affected by the Proposed Lake Eastex

Category	Dam, Spillway, and Construction Area (acres)	Total Area (acres)
Hillside Bog	0	1
New Channel	5	30
Intermittent Streams	0	47
Open Water	6	63
Shrub-scrub Wetlands	0	144
Perennial Streams	4	255
Herbaceous Wetlands	168	1,517
Forested Wetlands	37	3,689
TOTAL	220	5,746

Table 4-2. Vegetation Cover in the Lower Pool Area Before and After Disturbance

Category	1994 (acres)	2001 (acres)	Difference (acres)
Upland	623	621	-2
Forested Wetland	323	59	-264
Herbaceous Wetland	23	269	246
Shrub Wetland	0	2	2
Open Water	5	7	2
Intermittent Stream	5	5	0
Perennial Stream	12	2	-10
New Channel	0	25	25

4.3 Habitat Evaluation Procedures (HEP)

HEP is an analysis tool developed by USFWS to help quantify the impacts of human and naturally caused events on wildlife habitat and document the nonmonetary value of fish and wildlife resources. HEP was originally developed by the USFWS in 1974 and has been used across the nation to evaluate impacts from both large and small scale projects. The method relies on being able to measure and quantify species habitat characteristics (e. g. vegetation species composition, height of vegetation, frequency of flooding, etc.) that give a value or suitability of a given area for the selected wildlife species. For the system to work, the life requisites (what the specific animal needs for cover, reproduction, and food) must be quantified and the habitat variables that meet those needs must be measurable. The method can be used to provide an estimate of the quality and quantity of available habitat for selected wildlife species. Two general types of wildlife habitat comparisons can be made using HEP:

LIFE REQUISITES
What specific animals need for :
-Cover
-Reproduction
-Food

- 1) the relative value of different sites at the same point in time; and
- 2) the relative value of the same sites at future points in time.

The habitat quality for selected evaluation species is documented with an index (Habitat Suitability Index, HSI) on a scale of 0.0 to 1.0, with a ranking of 0.0 being unsuitable and 1.0 being optimal habitat. Optimum conditions are those associated with the highest potential densities of the species within a defined area. The HSI value obtained from this comparison thus becomes an index of carrying capacity for that species.

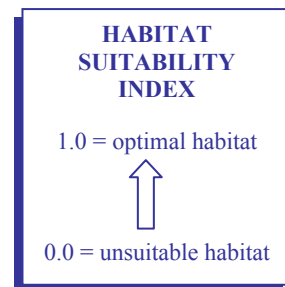

The index ranges from 0.0 to 1.0, and for operational purposes in HEP, each increment of change must be identical to any other. For example, a change in HSI from 0.1 to 0.2 must represent the same magnitude of change as a change from 0.2 to 0.3, and so forth. Therefore, HSI must be linearly related to carrying capacity. This is an operational restriction imposed by the use of HSI in HEP.

HSI values are obtained for individual species through use of documented habitat suitability models employing measurable key habitat variables. The HSI values are multiplied by the area of available habitat (cover types) to obtain Habitat Units (HU's) for individual species. These values are used in the HEP system for comparative purposes.

HABITAT UNITS

Are calculated by multiplying the average HSI values for all species within a given cover type by the acreage of the cover type.

HEP outputs can be used to assess environmental impacts by comparing the HUs available to each target species in pre-action and post-action scenarios. Additionally, if the areas of certain habitats are to be created or enhanced through mitigation, the effects of such changes can be compared with the unmitigated scenario.

In summary, this framework for determining habitat quality for wildlife species is designed to provide a consistent means of assessing project development impacts by:

- assigning an HSI value and determining the equivalent HUs for existing habitat conditions;
- determining the difference between the HUs of existing conditions and conditions that will result from a proposed project; and
- demonstrating, in HUs gained or lost, the beneficial or adverse impacts anticipated as a result of the project.

For mitigation analysis, the specific limitations of the project area as well as proposed mitigation land's habitat can be determined and, by implication, means for improving the habitat can be devised. For example, by identifying the habitat variable(s) causing a low HSI value, measures can be developed to enhance the variable. If the lack of hard mast trees causes low habitat quality, then plantings could help improve the habitat.

The generalized process for conducting a HEP study involves the following components (USFWS 1980):

- Determine the applicability of HEP and define the study limits;
- Determine habitat or vegetation cover types;
- Define the relevant species for evaluation;
- Determine each species' life requisites and measure habitat components for suitability;
- Determine baseline and future Habitat Units; and
- Develop compensation/mitigation plans for the proposed project.

4.3.1 Approach

**LAKE EASTEX
HEP TEAM**

USACE (lead)
USEPA
USFWS
TPWD
TWDB
TCEQ
FNI

The Lake Eastex HEP team was led by the U.S. Army Corps of Engineers and included the U.S. Environmental Protection Agency, U.S. Fish and Wildlife Service, Texas Parks and Wildlife Department, Texas Water Development Board, Texas Commission on Environmental Quality, and Freese and Nichols, Inc. The HEP team had oversight for the tasks that were required for the analysis including defining the study area; delineating cover types; field sampling, and selecting evaluation species.

The HEP methodology incorporated into this study is recommended by the USFWS as their basic tool for evaluating project impacts and developing mitigation recommendations (USFWS 1993). HEP has been used as a method to evaluate impacts to wildlife habitat for similar projects in Texas. By utilizing the previous HEP study for Lake Eastex that was conducted in 1988 (LAN 1991), the current analysis can be placed into historical context and rely on past decisions regarding applicability, sampling locations and model species selections. The group agreed that the 10 areas sampled in the 1988 HEP study at the proposed Lake Eastex site should be used for the present study. The HEP team decided that two additional areas should be added for this study.

4.3.2 Study Area and Methods

The study area is the geographic area where biological changes associated with the project are expected to occur. The proposed study area for the Lake Eastex Water Supply Project has the approximately 10,121-acre area that will be inundated at the normal pool elevation of 315 feet NGVD.

COVER TYPES

are descriptions of the vegetation present in a given area. Cover types represent the habitat available to animals living in the area.

The sampling areas presented in the 1991 report by LAN were used as a basis to develop a sampling plan within the normal pool elevation boundary; however, efforts were not made to duplicate the precise locations of the sites in the LAN study. The distribution of the 12 areas where 51 sites were sampled is illustrated in Figure 4-7. Sampling sites were named by area

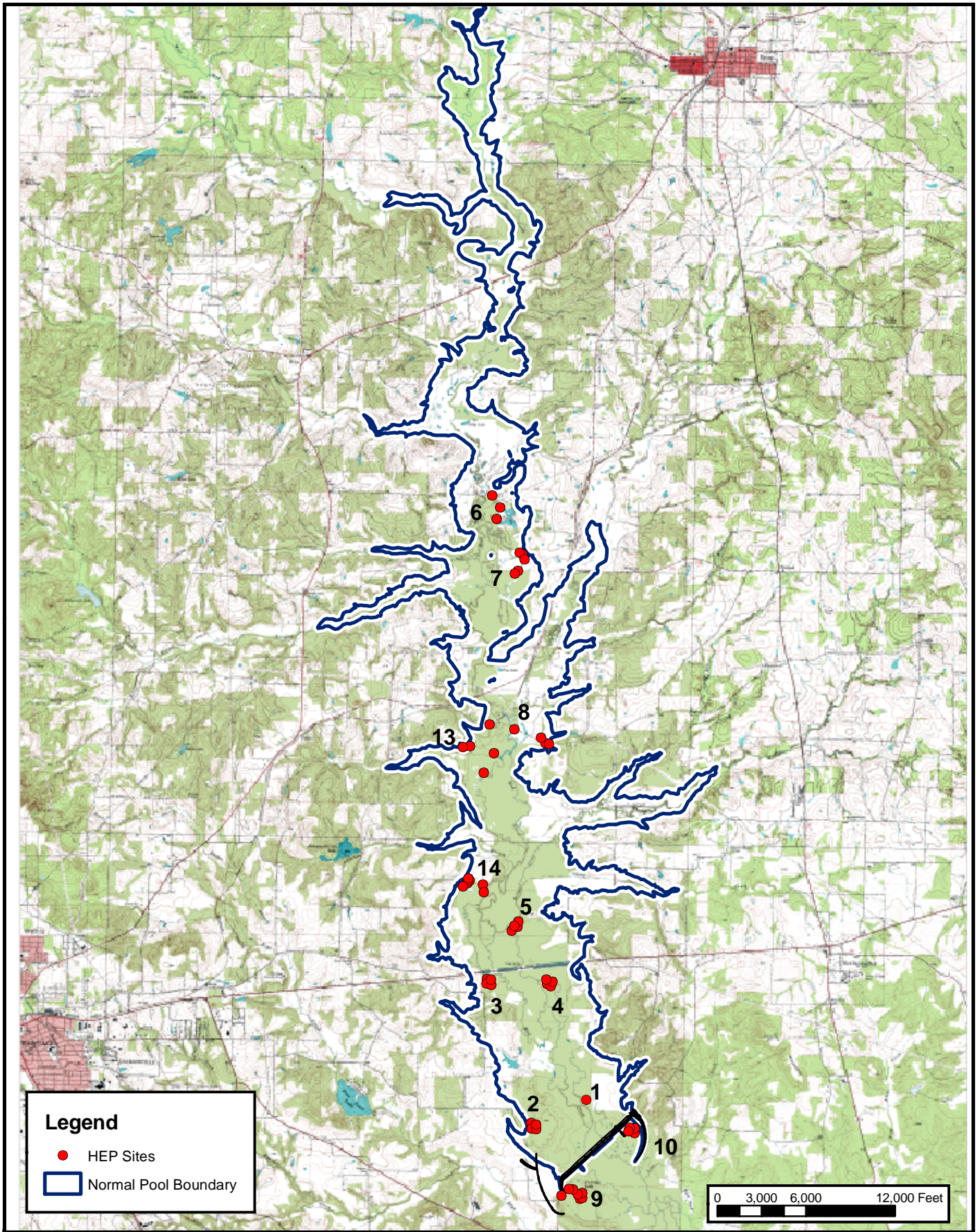

FREESE • NICHOLS
 4055 International Plaza Suite 200
 Fort Worth, Texas 76109-4895
 817-735-7300



**Angelina and Neches River Authority
 Proposed Lake Eastest**

**HEP Site Locations
 USGS Topo**

FN JOB NO	ANR01289
FILE	H:/HEP/HEPtopo-8x11.mxd
DATE	February 18, 2003
SCALE	1:110,000
DESIGNED	RH
DRAFTED	BAR

4-7
Figure

number and an alphabetic designation for each site in the area (e. g., Site 14 b). Field measurements were made within a 0.1 acre square quadrant at each site. A wetland delineation data form was completed for a point located at the approximate center of each quadrant.

Field sampling was conducted by the HEP team members during April 22-26, 2002. HEP sheets and wetland delineation forms recorded during this effort are provided in Volume II. Photographs taken at each site are presented in Volume II.

4.3.3 Cover Type Delineation

Cover types were delineated as described in Section 4-1 *Remote Sensing*, using digital color infrared photography flown on August 2, 2001. Cover type classifications that were used in the 1988 HEP study included bottomland hardwood forest, herbaceous and shrub wetlands, upland forest, riverine and lacustrine, and grassland. These cover types were used (when appropriate) for the 2002 classifications. Bottomland hardwood forest and deciduous forested wetland are synonymous in the report and are used interchangeably. Additional cover types or land uses delineated from the aerial photograph were roads, railroads, and urban. The location of sampling sites and the distribution of cover types used in the current study are shown in Figures 4-8a through 4-8g.

COVER TYPES

Deciduous Forested Wetland
Herbaceous Wetland
Shrub Wetland
Upland Forest
Shrub Land
Grassland
Lacustrine
Riverine
Urban

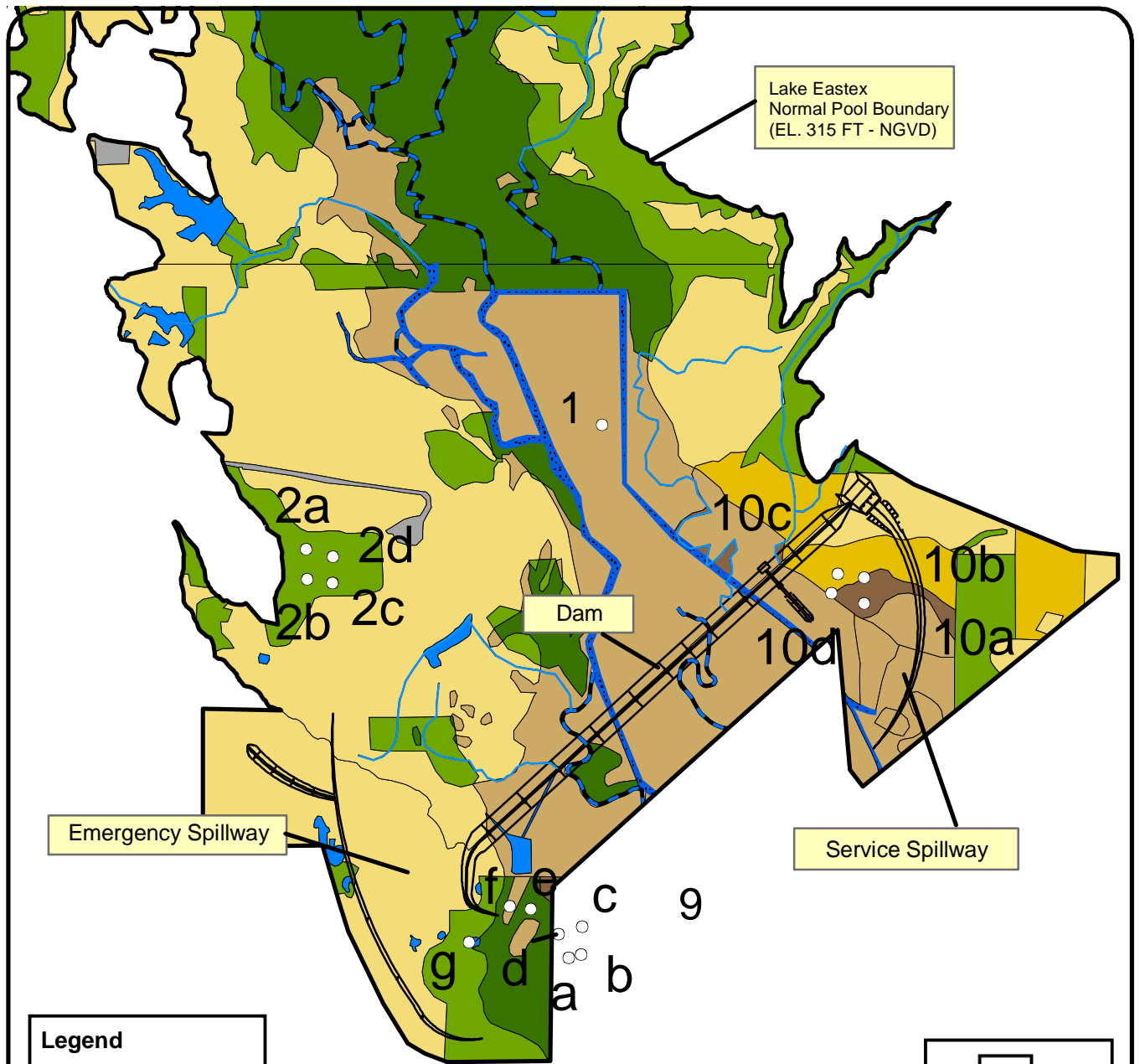

Legend

- Intermittent Stream
- Perennial Stream
- Forested Wetland
- Upland Forest
- Highways/Railroads
- Herbaceous Wetland
- Herbaceous Upland
- Shrub Wetland
- Shrub Upland
- Open Water
- Excavated Water
- Urban
- HEP Sites

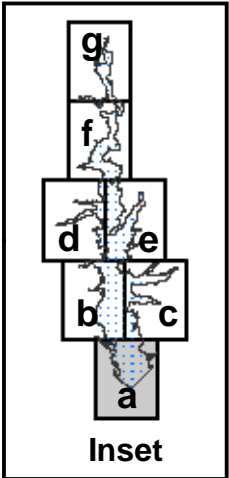
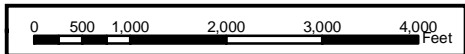

FRIESE-NICHOLS
 4055 International Plaza Suite 200
 Fort Worth, Texas 76109-4895
 817-735-7300



**Angelina and Neches River Authority
 Proposed Lake Eastex**

**HEP Sampling Site Locations
 Shown on Cover Type Map**

FN JOB NO	ANR01289
FILE	H/HEP/HEP Sites-Cover/8x11/1of7.mxd
DATE	December 6, 2002
SCALE	1:24,000
DESIGNED	BAR
DRAFTED	BAR

**4-8a
 FIGURE**

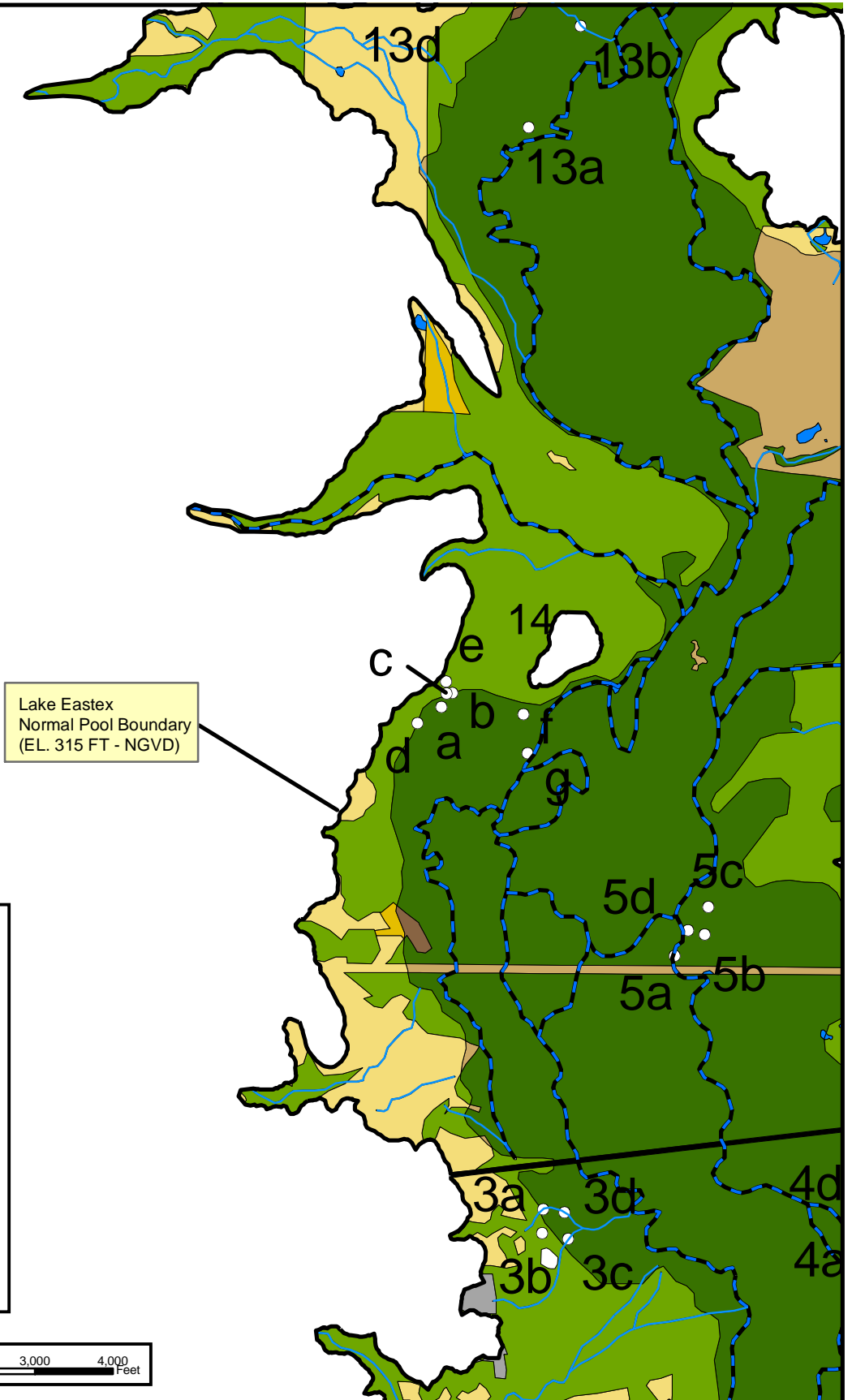
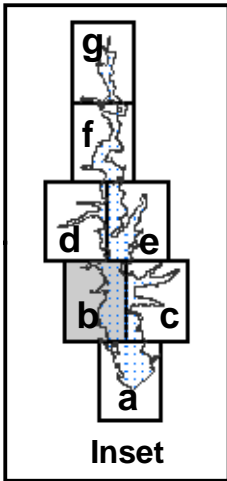

Legend

- Intermittent Stream
- Perennial Stream
- Forested Wetland
- Upland Forest
- Highways/Railroads
- Herbaceous Wetland
- Herbaceous Upland
- Shrub Wetland
- Shrub Upland
- Open Water
- Excavated Water
- Urban
- HEP Sites

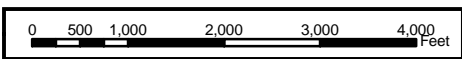

FRITSCHE-NICHOLS
 4055 International Plaza Suite 200
 Fort Worth, Texas 76109-4895
 817-735-7300



Angelina and Neches River Authority
Proposed Lake Eastex

HEP Sampling Site Locations
Shown on Cover Type Map

FN JOB NO	ANR01289
FILE	H:\HEP\HEP Sites-Cover\8x11\1of7.mxd
DATE	December 6, 2002
SCALE	1:24,000
DESIGNED	BAR
DRAFTED	BAR

4-8b
FIGURE

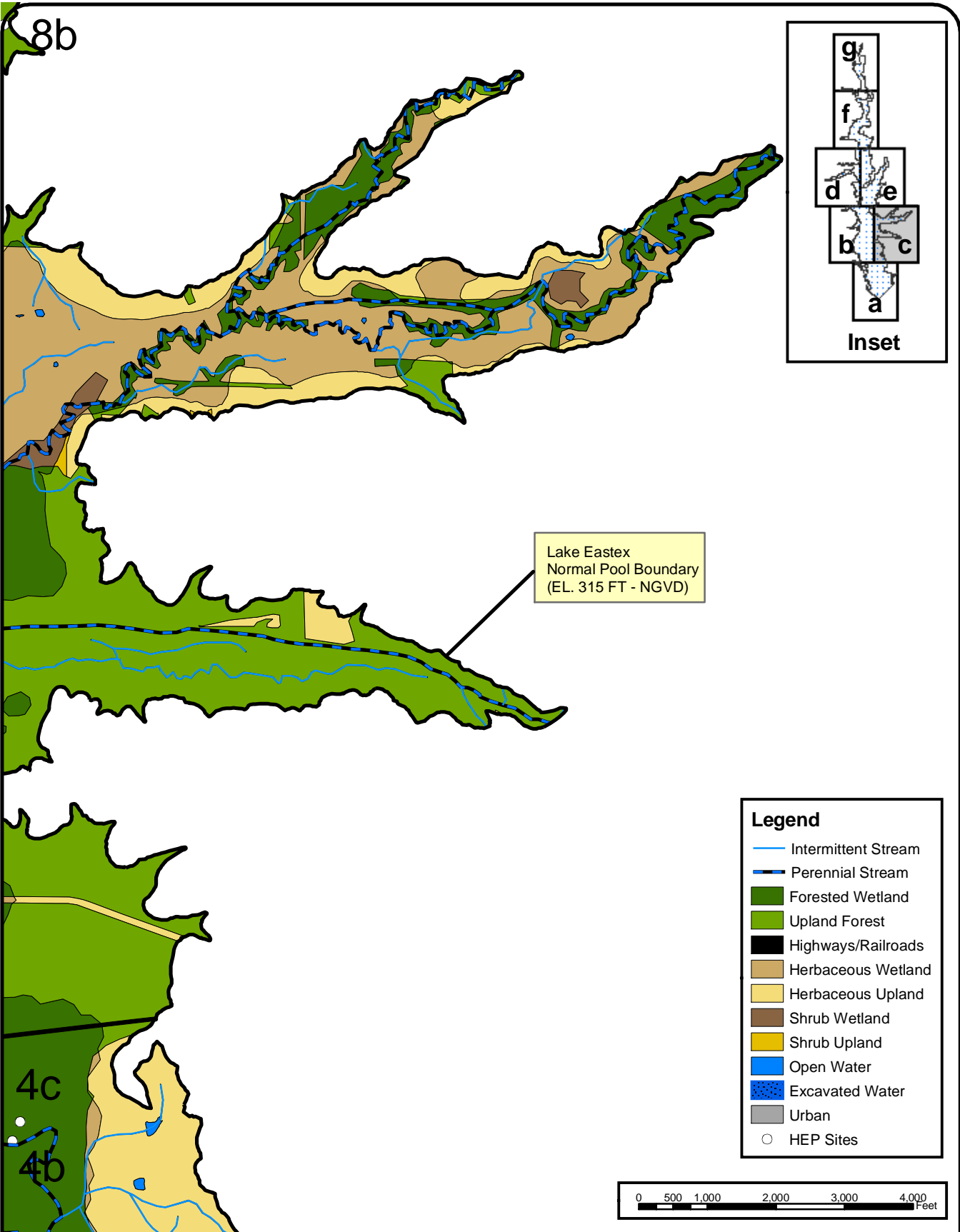

8b

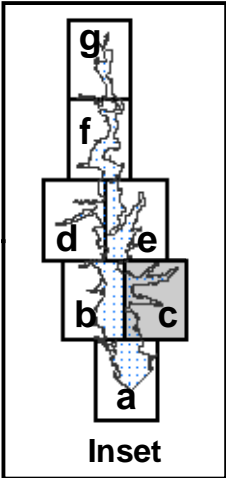

Lake Eastex
Normal Pool Boundary
(EL. 315 FT - NGVD)

Legend

- Intermittent Stream
- - - Perennial Stream
- Forested Wetland
- Upland Forest
- Highways/Railroads
- Herbaceous Wetland
- Herbaceous Upland
- Shrub Wetland
- Shrub Upland
- Open Water
- Excavated Water
- Urban
- HEP Sites

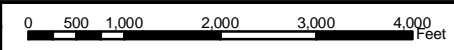

4c
4b

FREESC - NICHOLS
4055 International Plaza Suite 200
Fort Worth, Texas 76109-4895
817-735-7300



Angelina and Neches River Authority
Proposed Lake Eastex

HEP Sampling Site Locations
Shown on Cover Type Map

FN JOB NO	ANR01289
FILE	H/HEP/HEP Sites-Cover/8x11/3of7.mxd
DATE	December 6, 2002
SCALE	1:24,000
DESIGNED	BAR
DRAFTED	BAR

4-8c
FIGURE

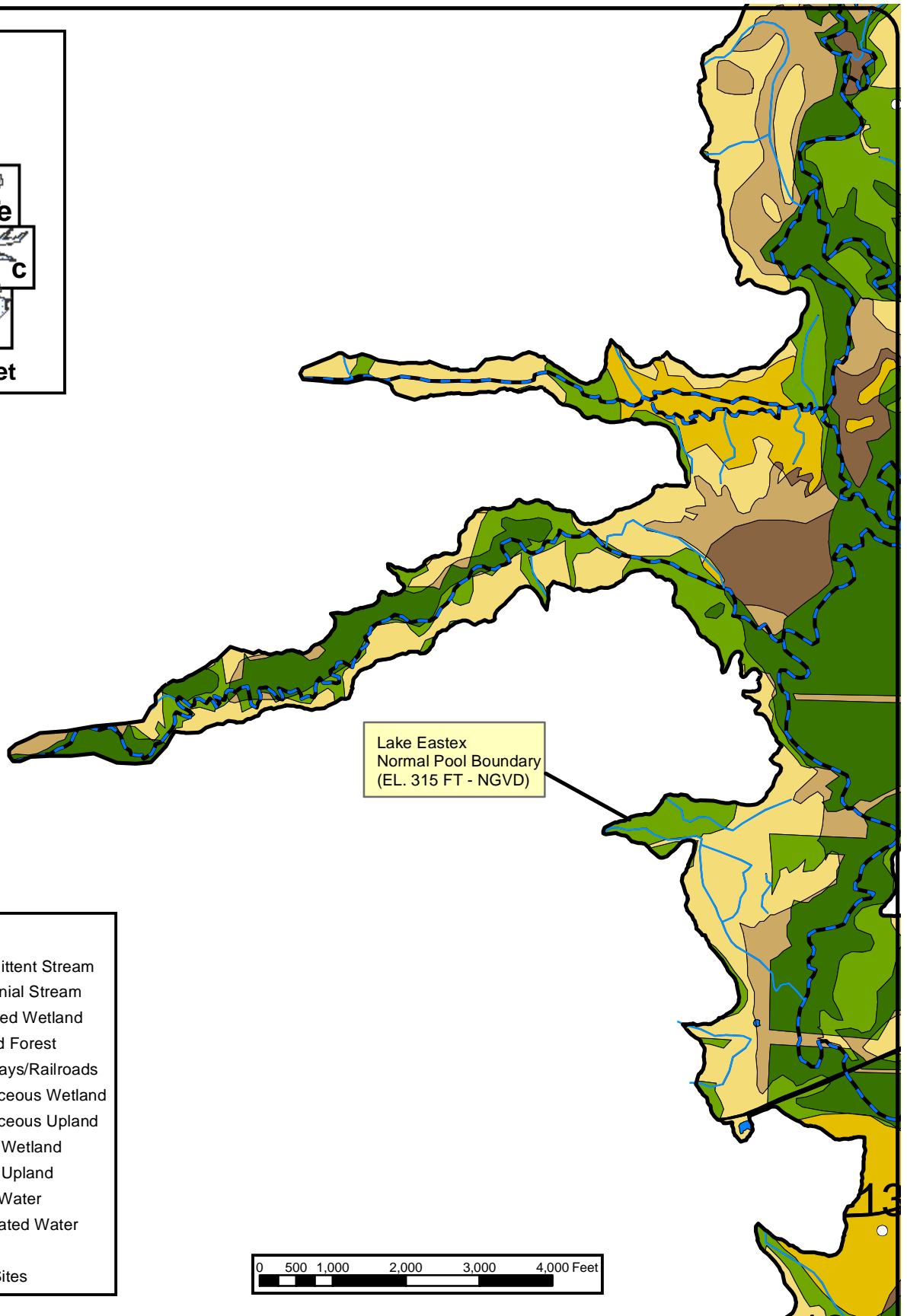
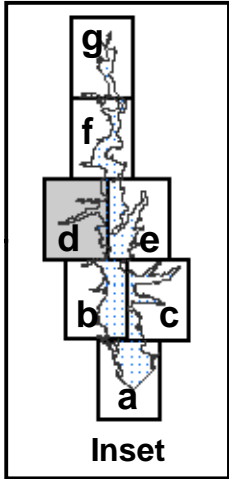

- Legend**
- Intermittent Stream
 - Perennial Stream
 - Forested Wetland
 - Upland Forest
 - Highways/Railroads
 - Herbaceous Wetland
 - Herbaceous Upland
 - Shrub Wetland
 - Shrub Upland
 - Open Water
 - Excavated Water
 - Urban
 - HEP Sites

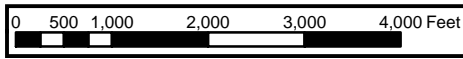

FREESE - NICHOLS
 4055 International Plaza Suite 200
 Fort Worth, Texas 76109-4895
 817-735-7300



**Angelina and Neches River Authority
 Proposed Lake Eastex**

**HEP Sampling Site Locations
 Shown on Cover Type Map**

FN JOB NO	ANR01289
FILE	H/HEP/ HEP Sites-Cover/8x11/4of7.mxd
DATE	December 6, 2002
SCALE	1:24,000
DESIGNED	BAR
DRAFTED	BAR

4-8d
FIGURE

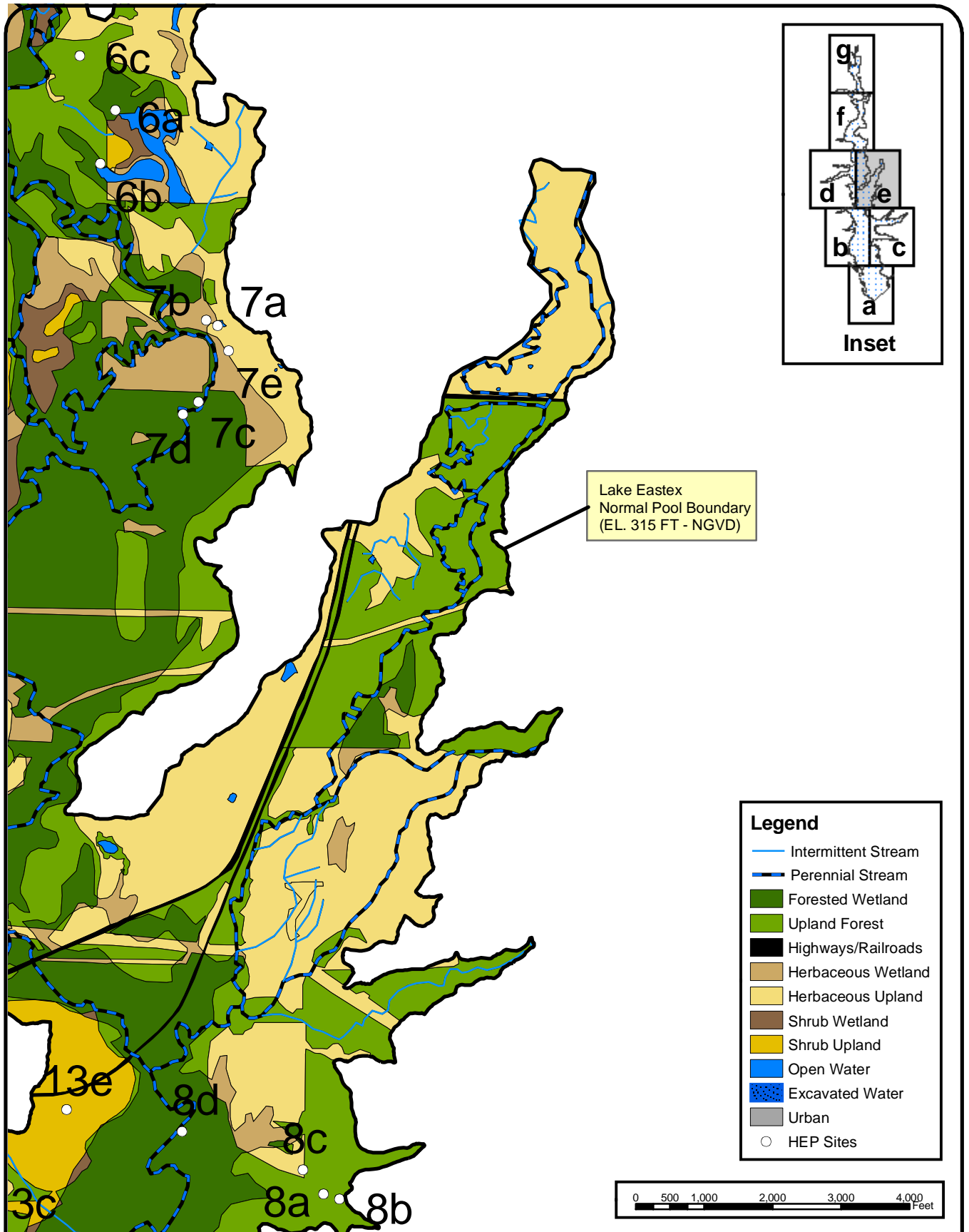

FREESE - NICHOLS
 4055 International Plaza Suite 200
 Fort Worth, Texas 76109-4895
 817-735-7300



**Angelina and Neches River Authority
 Proposed Lake Eastex**

**HEP Sampling Site Locations
 Shown on Cover Type Map**

FN JOB NO	ANR01289
FILE	H/HEP/
HEP Sites-Cover/8x11/5of7.mxd	
DATE	December 6, 2002
SCALE	1:24,000
DESIGNED	BAR
DRAFTED	BAR

**4-8e
 FIGURE**

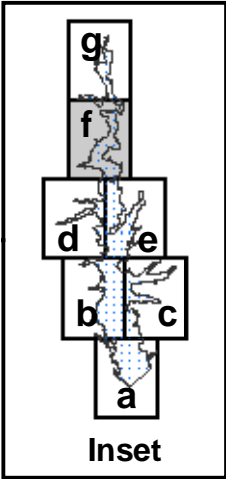

Inset

Legend

- Intermittent Stream
- Perennial Stream
- Forested Wetland
- Upland Forest
- Highways/Railroads
- Herbaceous Wetland
- Herbaceous Upland
- Shrub Wetland
- Shrub Upland
- Open Water
- Excavated Water
- Urban
- HEP Sites

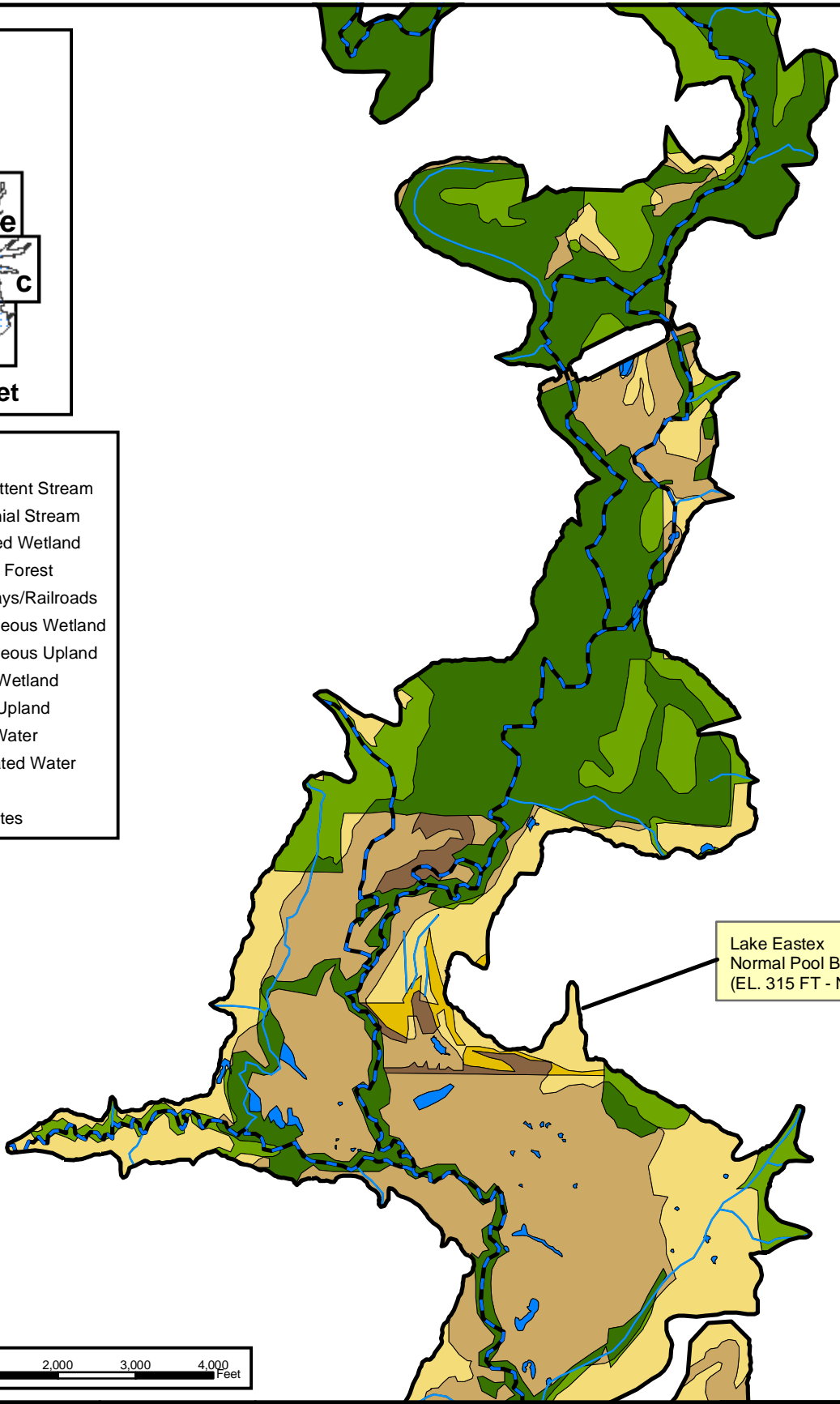

Lake Eastex
Normal Pool Boundary
(EL. 315 FT - NGVD)

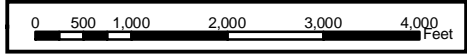

FRIESE-NICHOLS
4055 International Plaza Suite 200
Fort Worth, Texas 76109-4895
817-735-7300



Angelina and Neches River Authority
Proposed Lake Eastex

HEP Sampling Site Locations
Shown on Cover Type Map

FN JOB NO	ANR01289
FILE	H/HEP/HEP Sites-Cover/8x11/6of7.mxd
DATE	December 6, 2002
SCALE	1:24,000
DESIGNED	BAR
DRAFTED	BAR

4-8f
FIGURE

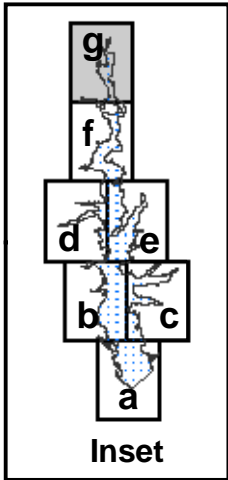

Legend

- Intermittent Stream
- - - Perennial Stream
- Forested Wetland
- Upland Forest
- Highways/Railroads
- Herbaceous Wetland
- Herbaceous Upland
- Shrub Wetland
- Shrub Upland
- Open Water
- Excavated Water
- Urban
- HEP Sites

Lake Eastex
Normal Pool Boundary
(EL. 315 FT - NGVD)

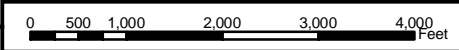

FREESE - NICHOLS
4055 International Plaza Suite 200
Fort Worth, Texas 76109-4895
817-735-7300



**Angelina and Neches River Authority
Proposed Lake Eastex**

**HEP Sampling Site Locations
Shown on Cover Type Map**

FN JOB NO	ANR01289
FILE	H:\HEP\HEP Sites-Cover\8x11\7of7.mxd
DATE	December 6, 2002
SCALE	1:24,000
DESIGNED	BAR
DRAFTED	BAR

4-8g
FIGURE

4.3.4 Evaluation Species

The wildlife species models used in the HEP study were the same as those used in the 1988 study (LAN 1991) with the addition of four species. Also, the nesting habitat component was added to the previous study's wood duck model.

The species models used in the 1988 study included the gray squirrel, swamp rabbit, belted kingfisher, barred owl, red-tailed hawk, green heron, and wood duck. Only the brood-rearing model was used for the wood duck. The current study included the previous species, plus the addition of the fox squirrel, eastern cottontail, eastern meadowlark, racer, and the wood duck (nesting habitat).

**SPECIES MODELS
USED IN 1988 STUDY**

Gray squirrel
Swamp rabbit
Belted kingfisher
Barred owl
Red-tailed hawk
Green heron
Wood duck (brood/rearing)

**SPECIES MODELS
ADDED FOR
CURRENT STUDY**

Eastern cottontail
Fox squirrel
Racer
Eastern meadowlark
Wood duck (nesting)

4.3.5 Species Descriptions and Habitat Requirements

Following are descriptions of the habitat preferences and life requisites for the study species, along with summary descriptions of the variables measured during the field studies performed in April 2002. Also included are assumptions made for variables that had seasonal components that could not be measured during the April sampling event. Measurements of habitat variables were recorded on field data forms located in Volume II, Appendix 10.

Barred Owl (*Strix varia*)

BARRED OWL

COVER TYPE:

Deciduous Forested Wetland
Deciduous Upland Forest

LIFE REQUISITES

Large, living trees
Adequate nesting cavities

Barred owls are a forest dwelling species that prefer expansive, mature forests with open sub-canopies allowing for the flying space needed for hunting small game. The species shows no marked preference between upland and bottomland forests. However, since upland forests are more accessible to logging, forested wetland sites less accessible to timber harvest are presently more likely to provide for their needs. Specifically, barred owl habitat must provide large, decadent trees with adequate numbers of nesting cavities, although nesting has been recorded in abandoned raptor nests. Due to the foliage cover, live trees provide superior nesting sites compared to snags (Allen 1987).

Belted Kingfisher (*Ceryle alcyon*)

BELTED KINGFISHER

COVER TYPE:

Lacustrine
Riverine

LIFE REQUISITES

Clear, calm shallow streams
Branches for perching
Riffles for fishing

Belted kingfishers hunt for small fish, crawfish, and other small animals in streams, lake edges, beaver ponds, seacoasts and estuaries. Preferred feeding habitat consists of large, open streams with clear water and a lack of heavy vegetation. The best sites are protected from excessive wind and wave action. Belted Kingfishers frequently fish at stream riffles where their prey species often congregate. Bare branches overhanging their hunting waters are used as perches from which they can watch for prey, although piers and telephone wires are also used. Nesting holes are excavated into high; vertical cut banks, usually consisting of sandy clay or other friable soil types. Tree roots interfere with cavity excavation; so treeless stream banks are preferred nesting sites. Nests are usually situated near suitable hunting sites (Prose 1985).

Downy Woodpecker (*Picoides pubescens*)

Downy woodpeckers show a preference for open woodlots, but the species is found across North America wherever there are trees from which they can drill and glean for the insects they eat. They inhabit both coniferous and deciduous forests. These woodpeckers are not strong excavators, so their nest cavity placement is limited by the availability of soft snags, often with both surface sap rot and fungal heart rot. Living trees with broken crowns are also chosen as nesting sites (Schroeder 1982).

DOWNY WOODPECKER

COVER TYPE:

Deciduous Forested Wetland
Deciduous Upland Forest

LIFE REQUISITES

Open woodlots
Soft snags

Eastern Meadowlark (*Sturnella magna*)

EASTERN MEADOWLARK

COVER TYPE:

Grassland

LIFE REQUISITES

Herbaceous or grassy canopy
Nearby perch sites

Eastern meadowlarks inhabit grasslands, meadows, pastures, and fallow fields in the south and central United States. While they do need numerous perch sites, such as tall forbs, shrubs, small trees, and fences, their preferred habitat consists of relatively open grasslands with low shrub and forb coverage. Eastern meadowlarks are a ground-nesting species, so groundcover must be thick for nest concealment (Schroeder

and Sousa 1982).

Green Heron (*Butorides virescens*)

Cover types frequented by the green heron include Bottomland Hardwood (Deciduous Forested Wetland), Herbaceous Wetland, Lacustrine, Shrub Wetland (Deciduous Shrub Wetland), and Riverine.

Green herons are predators that wade in the shallow waters of rivers, lakes, ponds lagoons, ditches, marshes, and swamps, where they hunt for fish, frogs, crawfish, and other aquatic animals. They are adaptable generalists within these aquatic environments and inhabit both fresh and salt-water ecosystems. Preferred feeding habitat consists of open, permanent, shallow waters that are free of emergent aquatic vegetation. Ideally, adequate cover such as dense stands of reeds and cattails, which also provide nesting areas, are available in close proximity to hunting sites. More often, nests are built in shrubs or small trees near the shoreline (Author Unknown, Green Heron HSI Model Review Copy 1980).

GREEN HERON

COVER TYPE:
Deciduous forested wetland
Herbaceous wetland
Shrub wetland
Lacustrine
Riverine

LIFE REQUISITES
Shallow, open water
Nearby shrubs or small trees

Red-tailed Hawk (*Buteo jamaicensis*)

RED-TAILED HAWK

COVER TYPE:
Grassland
Upland forest
Shrubland

LIFE REQUISITES
Mature woodlands
Open fields
Scattered trees

The most common of the buteos in North America, red-tailed hawks inhabit mature woodlands, woodlots, and open fields with scattered trees. They search for small prey by perching or soaring over grasslands, agricultural fields, and fallow lands. Snags are preferred perching sites. Red-tailed hawk nests are typically built in large trees along woodland edges. Nighttime and winter roosts are usually found in dense timber, especially conifers (Author Unknown, Red-tailed Hawk HSI Model Review Copy 1980).

Wood Duck (*Aix sponsa*)

WOOD DUCK

COVER TYPE:

Deciduous forested wetland
Herbaceous wetland
Shrub wetland
Upland forest
Riverine

LIFE REQUISITES

Slow moving waters
Aquatic vegetation
Mature hardwood forest
Protected "loafing" sites

Year-around residents in the southeast United States, wood ducks inhabit slow moving creeks and rivers, as well as floodplain lakes, swamps, and beaver ponds. Since wood ducks nest in tree cavities, ideal nesting habitat is mature hardwood forest proximal to aquatic feeding sites. Mast and aquatic vegetation make up the majority of their food-sources. Wood ducks require adequate loafing sites that have good visibility, are nearby cover, and are adjacent to or surrounded by water. Such sites can be a limiting factor for quality wood duck habitat (Sousa

and Farmer 1983).

Eastern Cottontail (*Sylvilagus floridanus*)

Eastern cottontails are habitat generalists within a wide range of early to mid-succession habitats. Required quality habitat parameters include an abundance of well-distributed escape cover and open areas for their nocturnal browsing. This combination often consists of old-field bordered by shrubby edge habitat. Eastern cottontails also need dense, heavy thickets or hedgerows for resting and daytime shelter. Nests are usually located in thick grass cover, including hayfields and fallow fields near escape cover (Allen 1984).

EASTERN COTTONTAIL

COVER TYPE:

Grassland
Upland forest
Shrubland

LIFE REQUISITES

Fields with shrubby edges
Dense thickets or hedgerows
Thick grass or hayfields

Fox Squirrel (*Sciurus niger*)

FOX SQUIRREL

COVER TYPE:

Deciduous forested wetland
Upland forest

LIFE REQUISITES

Open forests
Little understory
Nearby grain

While fox squirrels prefer open forest stands with little understory vegetation, they will inhabit a wide variety of forest types. Upland and well-drained bottomland forest habitats are used more often than poorly drained lowland areas. Small stands of large trees situated in agricultural areas allow fox squirrels to supplement their diet, which consists of mast and a variety of other plant and animal foods, with grains as needed.

Mature mast trees provide both food and nesting sites. Fox squirrels will nest in tree cavities, but also build leaf nests; therefore, quality habitat is not limited by the availability of nesting cavities (Allen 1982a).

Gray Squirrel (*Sciurus carolinensis*)

Gray squirrel preferred habitat consists of large, dense forests dominated by saw-timber sized mast trees with closed canopies and well-developed under-stories. They also inhabit mixed hardwood/conifer forests. Open water is a necessary factor in gray squirrel habitat, and the species is found most often in poorly drained, lowland forests. Gray squirrels usually nest in tree cavities (Allen 1982b).

GRAY SQUIRREL

COVER TYPE:
Deciduous forested wetland
Upland forest

LIFE REQUISITES
Large, dense forests
Closed canopies
Thick understories
Open water

Swamp Rabbit (*Sylvilagus aquaticus*)

SWAMP RABBIT

COVER TYPE:
Deciduous forested wetland
Herbaceous wetland
Deciduous shrub wetland

LIFE REQUISITES
Open overstory canopies
Dense understories
Fallen trees, stumps, or logs

Swamp rabbits are associated with wetland habitats in the southeast United States, including bottomland hardwood forests and coastal marshes. In forested settings they prefer open overstory canopies and dense understories that provide for abundant browse. Brush-piles, downfalls, dense herbaceous vegetation such as vine tangles and even standing, hollow trees provide for swamp rabbit cover. They use tree stumps, logs, and low tree crotches for their resting sites (called forms). The forms must be situated near adequate escape cover (Allen 1985).

Racer (*Coluber constrictor*)

Racers are snakes that live in grasslands, open woods, and brushy areas. Tall-grass prairie is ideal summer habitat, but pastureland, brushy ravines, hay and grain-fields, and open woodlands with adequate cover are widely used by the species. Eggs are often laid in the tunnels of burrowing mammals as well as in rotten logs and stumps. In the fall, racers migrate to rocky outcroppings and ledges with southern exposures where they hibernate in deep crevices (Author Unknown, Racer HSI Model Review Copy 1980).

RACER

COVER TYPE:
Shrubland

LIFE REQUISITES
Herbaceous canopy cover
Tunnels or other refuge sites

4.3.6 Cover Type Descriptions

The following descriptions of cover types are based on the results of field measurements and observations made during April 2002. A table follows each cover type description detailing the results of field measurements for each of the habitat variables needed for calculation of suitability indices (SIs) and HSI values.

Bottomland Hardwood Forest (Deciduous Forested Wetland)

**DECIDUOUS
FORESTED
WETLANDS**
(USFWS 1980)

Dominated by woody vegetation at least 6 meters tall, with a total vegetation cover > 30 percent.

Bottomland hardwood forest in the proposed Lake Eastex project area is associated with the Mud Creek floodplain. Average tree canopy cover in the forest equals approximately 85 percent, while the shrub and herbaceous canopy covers equal approximately 41 percent and 39 percent, respectively. Dominant trees include willow oak (*Quercus phellos*), overcup oak (*Q. lyrata*), American elm (*Ulmus americana*), sweet gum (*Liquidambar styraciflua*), sugar hackberry (*Celtis laevigata*), and water oak (*Q. nigra*). Average diameter at breast height (DBH) of overstory trees equals approximately 13 inches and basal area in the forest averages 99 square feet per acre. Dominant plants in the shrub strata are often small trees, such as those listed above, and may also include swamp tupelo (*Nyssa sylvatica*), deciduous holly (*Ilex decidua*), and American beautyberry (*Callicarpa americana*). Common vines in the bottomland hardwood forest include green briar (*Smilax* spp.), poison ivy (*Toxicodendron radicans*), trumpet creeper (*Campsis radicans*), and Japanese honeysuckle (*Lonicera japonica*), while common herbaceous plants include lizard's tail (*Saururus cernuus*), sedges (*Carex* spp.), goldenrod (*Salidago* spp.), and smartweed (*Polygonum* spp.). Canopy cover of the herbaceous stratum averages at about 30 percent. Complete results of HEP field measurements for this cover type are shown in Table 4-3. There are approximately 3,652 acres of bottomland hardwood forest in the proposed Lake Eastex conservation pool area.

Signs of deer (*Odocoileus virginianus*), bobcats (*Lynx rufus*), raccoons (*Procyon lotor*), and feral hogs (*Sus scrofa*) are common in the project area bottomland hardwood forests. Common avian species in the area include pileated woodpecker (*Dryocopus pileatus*), eastern-tufted titmouse (*Parus bicolor*), wood duck (*Aix sponsa*), Carolina wren (*Thryothorus ludovicianus*), and red-shouldered hawk (*Buteo lineatus*).

Table 4-3. Habitat Variable Measurements at Deciduous Forested Wetland Sites

Lake Eastex HEP Field Data Summary																		
Cover Type: Deciduous Forested Wetland																		
<i>Species: Swamp Rabbit, Green Heron, Downy Woodpecker, Wood Duck, Gray Squirrel, Fox Squirrel, Barred Owl</i>																		
Variable	Area/Site Number																	Avg
	3A	3B	3C	4C	4D	5B	5C	6A	7D	9A	9B	9C	9D	13B	14A	14C	14F	
% herbaceous canopy cover (forested wetland)	35	55	30	45	96	17	32	20	2	1	2	1	2	50	2	47	70	30
Average height of herbaceous canopy (feet)	1.0	1.0	1.0	0.8	0.5	0.8	1.4	1.3	0.3	0.0	0.5	0.5	0.7	0.9	0.4	1.5	1.3	0.8
% canopy closure of trees that produce hard mast >10 in dbh	75	97	72	20	10	17	99	82	50	84	93	94	72	5	97	75	50	64
# yards to available grain	1000	1000	1000	1000	1000	1000	1000	1000	1000	1000	1000	1000	1000	1000	1000	1000	1000	1000
Avg dbh of overstory trees	17	13	12	12	9	10	9	13	15	15	12	13	15	10	10	16	15	13
% tree (>16.5 ft height) canopy closure	78	97	94	32	96	99	99	82	100	84	93	94	96	90	97	96	94	89
% shrub (<16.5 ft height) crown cover	15	25	55	25	85	60	75	20	47	2	35	45	50	50	0	50	60	41
Diversity of hard mast trees	3	2	2	3	2	5	3	3	3	2	4	3	2	4	1	3	3	3
Water regime (permanence of surface water)	5	4	4	1	5	4	4	1	4	4	4	4	4	4	4	4	4	4
Mean dbh of overstory trees >80% of height of tallest tree in stand	17	13	12	12	9	10	9	13	15	15	12	13	15	10	10	16	18	13
Water regime (avg summer conditions)	2	1	1	2	2	1	1	1	1	1	1	1	1	1	1	1	1	1
% water surface obstruction	0	0	0	2	0	0	0	8	5		0	0		0	20	5	2	3
% canopy cover of overstory trees	78	86	94	32	96	99	99	82	100	84	93	94	96	50	97	75	94	85
# trees >20" dbh/acre	10	0	0	0	0	0	10	0	0	0	0	0	10	0	0	20	10	4
Aquatic substrate composition in littoral zone	1	1	1	1	1	1	1	1	1	1	1	1	1	1	1	1	1	1
% water area <10 in deep	0	0	0	8	1	0	0	28	0	80	0	0	0	0	100	2	0	13
% emergent herbaceous canopy cover in littoral zone	0	0	0	2	0	0	0	90	0	0	0	0	0	0	1	0	0	5
Water current (avg summer conditions)	2	2	2	1	2	2	2	1	1	2	1	1	1	1	1	1	1	1
Miles to deciduous forested or deciduous shrub wetland	.25	.25	.25	.25	.25	.25	.25	.25	.25	.25	.25	.25	.25	.25	.25	.25	.25	.25
# nest boxes/acre	0	0	0	0	0	0	0	0	0	0	0	0	0	0	0	0	0	0
# potential nest sites per ac.	30	10	30	20	30	10	40	40	20	10	20	30	10	10	10	50	10	22
% water surface covered by potential winter cover	25	25	25	25	25	25	25	30	25	25	25	25	25	25	40	25	25	26
% water surface covered by potential brood cover	25	25	25	25	25	25	25	30	25	25	25	25	25	25	40	25	25	26
Basal area (sq.ft./ac)	90	90	100	20	80	130	140	110	100	140	70	150	100	70	140	100	50	99
# snags >6 in. dbh/ac	30	10	30	20	30	10	40	40	20	20	20	0	0	6	0	50	10	20

Upland Forest (Deciduous Upland Forest)

**DECIDUOUS
UPLAND
FORESTS**
(USFWS 1980)

Non-wetland
areas dominated
by trees and with
a minimal tree
canopy closure of
25 percent.

Upland forests in the project area are typically mixed hardwood/pine stands with thick sub-canopies of young trees, shrubs, and vines. Dominant tree species include water oak, post oak (*Q. stellata*), southern red oak (*Q. falcata*), loblolly pine (*Pinus taeda*), shortleaf pine (*P. echinata*), sweet gum, winged elm (*U. alata*), and eastern red cedar (*Juniperus virginiana*). Average tree canopy closure and basal area equal approximately 79 percent and 80 square feet per acre, respectively.

Common shrub and vine species include common persimmon (*Diospyros virginiana*), American beautyberry, blackberry (*Rubus* spp.), Japanese honeysuckle, and green briar. Shrub canopy closure in the typical upland forest averages about 58 percent. Dominant herbs include boneset (*Eupatorium* spp.), corn salad (*Valerianella* spp.), sweet clover (*Melilotus* spp.), and dock (*Rumex* spp.). Average herbaceous canopy cover equals approximately 74 percent. Complete results of HEP field measurements for this cover type are shown in Table 4-4. The upland forest cover type makes up approximately 2,245 acres of the proposed Lake Eastex conservation pool area.

Eastern bluebirds (*Sialia sialis*), pine warblers (*Dendroica pinus*), eastern tufted-titmice, and a variety of other songbirds have been detected in upland forests within the project area. Common reptiles and amphibians include broad-headed and five-lined skinks (*Eumeces laticeps* and *E. fasciatus*, respectively) and gray tree frogs (*Hyla* spp.) Mammals such as armadillos are also common in upland forests.

Table 4-4. Habitat Variable Measurements at Deciduous Upland Forest Sites

Lake Eastex HEP Field Data Summary									
Cover Type: Upland Forest									
<i>Species: Eastern Cottontail, Downy Woodpecker, Gray Squirrel, Fox Squirrel, Barred Owl, Red-tailed Hawk</i>									
Variable	Area/Site Number								Avg
	2A	2B	2C	2D	6C	8A	8B	14E	
% herbaceous canopy cover	80	90	90	100	5	90	75	60	74
% canopy closure of trees that produce hard mast >10 in dbh	5	0	10	0	98	0	0	94	26
Distance to available grain	1000	1000	1000	1000	1000	1000	1000	1000	1000
Average dbh of overstory trees	14	17	13	0	9	8	8	22	11
% tree (>16.5 ft tall) canopy closure	52	81	87	16	100	94	100	99	79
% shrub (<16.5 ft tall) crown cover	4	2	2	5	35	75	55	65	30
% canopy closure of persistent herbaceous vegetation	50	50	65	82	1	30	65	55	50
Diversity of hard mast tree species	2	2	2	1	2	0	0	4	2
Mean dbh of overstory trees >80% of height of the tallest tree in stand	14	17	13	0	9	8	8	22	11
% canopy cover of overstory trees	52	81	87	16	100	94	100	90	78
% herbaceous canopy 6-24 in tall	72	80	75	95	4	80	70	55	66
# trees >20" dbh/acre	0	20	0	0	0	10	0	30	8
# woody stems (>1 m tall) per acre	80	60	50	0	1600	500	325	900	439
Basal area (ft ² per acre)	60	50	50	10	120	100	110	140	80
# snags >6 in dbh/acre	0	0	0	0	2	40	20	40	13

Shrubland

SHRUBLAND
(USFWS 1980)

Dominated by shrubs (including small trees < five meters tall)

Shrub canopy cover of at least 25 percent

Shrublands in the project area represent a midpoint in the successional transition from upland oldfield or pasture to forest. Most of the shrub stratum species are small trees such as elms, oaks, sweet gum, and pines mixed with shrub species such as eastern false-willow (*Baccharis halimifolia*), sumac (*Rhus* spp.), Mexican plumb (*Prunus mexicana*), and rusty black-haw (*Viburnum rufidulum*). Shrub canopy cover averages approximately 68 percent, while tree canopy cover averages less than 1 percent. Common vines include blackberry, honeysuckle, and grape (*Vitis* spp.), while common herbaceous vegetation includes sedges, corn salad, rabbit-tobacco (*Evax verna*), and sweet clover. Average herbaceous canopy cover equals approximately 91 percent. Complete results of HEP field measurements for this cover type are shown in Table 4-5. There are approximately 235 acres of shrubland within the proposed Lake Eastex conservation pool.

Shrubland bird species observed in the project area include indigo bunting (*Passerina cyanea*) and blue grosbeak (*Guiraca caerulea*).

Table 4-5. Habitat Variable Measurements at Shrubland Sites

Lake Eastex HEP Field Data Summary				
Cover Type: Shrubland				
<i>Species: Eastern Cottontail, Red-tailed Hawk, Racer</i>				
Variable	Area/Site Number			Average
	13C	13E	14D	
% canopy closure of persistent herbaceous vegetation	74	56	75	68.25
% herbaceous canopy cover (herbaceous wetland)	98.0	75.0	100.0	91.00
Average height of herbaceous canopy (feet)	0.7	1.0	0.9	0.86
% tree (>16.5 ft height) canopy closure	0.0	1.0	0.0	0.33
% shrub (16.5 ft height) crown closure	45.0	100.0	60.0	68.33
Distance to deciduous forested or deciduous shrub wetland	750.0	500.0	75.0	441.67
# of refuge sites per acre	30.0	150.0	70.0	83.33
Distance to shrubby edges or shrub thickets (feet)	70.0	0.0	0.0	23.33
Diversity index: ratio of cover type edge to total area	NA	NA	NA	NA
% herbaceous canopy 6-24 " tall	80.0	70.0	90.0	80.00
# of woody stems >1-m	180	2000	1000	1060.00
# trees >20" dbh	0.0	0.0	0.0	0.00

Shrub Wetland

**SHRUB
WETLAND**
(USFWS 1980)

Vegetation
dominated by
shrubs

Includes shrub-
dominated
riparian zones

Shrub wetlands in the study area can be considered wetlands in successional transition between herbaceous wetlands and bottomland hardwood forests. Dominant shrubs include eastern false-willow, deciduous holly (*Ilex decidua*), and buttonbush (*Cephalanthus occidentalis*). Shrub canopy cover averages approximately 62 percent. Trees include overcup oak, willow oak, loblolly pine, and red maple (*Acer rubrum*), providing a canopy cover of approximately 21 percent. Common vines in shrub wetlands include green briar, wisteria (*Wisteria* spp.), blackberry, and pepper vine (*Ampelopsis arborea*). Dominant herbaceous plants include soft rush (*Juncus effusus*), American snowbell (*Styrax americana*), lizard's tail, sedges, and smartweed. Herbaceous canopy cover averages about 72 percent. Complete results of HEP field measurements for this cover type are shown in Table 4-6. One hundred forty three acres of the proposed Lake Eastex pool consist of the shrub wetland cover type.

A variety of songbirds, including yellow-breasted chat (*Icteria virens*), were observed in project area shrub wetlands. Signs of beaver (*Castor canadensis*) were also observed.

Table 4-6. Habitat Variable Measurements at Shrub Wetland Sites

Lake Eastex HEP Field Data Summary			
Cover Type: Shrub Wetland			
<i>Species: Swamp Rabbit, Wood Duck, Green Heron</i>			
Variable	Area/Site Number		Average
	9E	10C	
% herbaceous canopy cover (forested wetland)	NA	NA	NA
% herbaceous canopy cover (herbaceous wetland)	45.0	98.0	71.50
Average height of herbaceous canopy	0.5	1.8	1.13
% tree (>16.5 ft height) canopy closure	37.0	5.0	21.00
% shrub (<16.5 ft height) crown cover	80.0	45.0	62.50
Water regime (permanence of surface water)	NA	NA	NA
Water regime (average summer conditions)	2	2	2.00
% water surface obstruction	75.0	0.0	37.50
Aquatic substrate composition in littoral zone	1.0	1.0	1.00
% water area <10 in deep	30.0	20.0	25.00
% emergent herbaceous canopy cover in littoral zone	90.0	60.0	75.00
Water current (average summer conditions)	2	2	2.00
Distance to deciduous forested or deciduous shrub wetland	0.0	0.0	0.00
Density of potential nest cavities per acre	NA	NA	NA
# of nest boxes/acre	0.0	0.0	0.00
# of potential nest sites per acre	40.0	0.0	20.00
% of water surface covered by potential winter cover	75.0	5.0	40.00
% of water surface covered by potential brood cover	80.0	10.0	45.00

Grassland

GRASSLAND
(USFWS 1980)

Includes most
prairies and rangeland

Dominated by
grasses & non-woody
vegetation

Canopy cover of at
least 25 percent

Grasslands in the project area are generally upland improved pastures of Bermuda grass (*Cynodon dactylon.*), typically the result of forest clearing. Common forbs include nettles (*Solanum* spp.), yankeeweed (*Eupatorium compostifolium*), corn salad, and goldenrod. Herbaceous canopy cover averages approximately 98 percent, while the herbaceous canopy height averages about 0.7 feet. Complete results of HEP field measurements for this cover type are shown in Table 4-7. Grassland in the proposed Lake Eastex conservation pool covers an area of approximately 2,381 acres.

Table 4-7. Habitat Variable Measurements at Grassland Sites

Lake Eastex HEP Field Data Summary				
Cover Type: Grassland				
<i>Species: Eastern Meadowlark, Red-tailed Hawk, Eastern Cottontail</i>				
Variable	Area/Site Number			Average
	1A	7B	13D	
% tree (>16.5 ft height) canopy closure	0	0	0	0.0
% shrub (<16.5 ft height) crown cover	0	0	0	0.0
% canopy closure of persistent herbaceous vegetation	80	75	60	71.7
Diversity Index; ratio of cover type edge to total area	1	1	1	1.0
Average height of herbaceous canopy (feet)	1.1	0.7	0.3	0.7
Distance to shrubby edges or shrub thickets (feet)	150	50	50	83.3
# of refuge sites per acre	0	0	0	0.0
% herbaceous canopy cover	95	100	100	98.3

Herbaceous Wetland

**HERBACEOUS
WETLAND**
(USFWS 1980)

Dominated by erect,
rooted, herbaceous
hydrophytes and plants
that grow on or below
the water

Total vegetation
cover > 30 percent

The Herbaceous Wetland type is dominated by erect, rooted, herbaceous hydrophytes and plants that grow principally on or below the surface of the water for most growing seasons in most years. It has a total vegetation cover of greater than 30 percent (USFWS 1980).

Herbaceous wetlands in the project area are dominated by wetland obligates such as rushes, sedges, smartweed, and lizard's tail. Common forbs include goldenrod and morning glory (*Ipomoea* spp.). Native grasses, such as switch grass (*Panicum virgatum*) and various bluegrasses (*Andropogon* spp.) are also readily found. Shrubs common to the cover type include buttonbush, eastern false-willow, and small trees such as sweetgum, black gum (*Nyssa sylvatica*), and black willow (*Salix nigra*). Vines found in the project area's herbaceous wetlands include pepper vine, trumpet creeper, blackberry, and wisteria. Herbaceous canopy cover averages about 95 percent with an average height of approximately 3.5 feet. Shrub canopy cover averages about 7 percent. Complete results of HEP field measurements for this cover type are shown in Table 4-8. There are approximately 1,517 acres of herbaceous wetland within the conservation pool area of the proposed Lake Eastex.

Marsh wrens (*Cistothorus palustris*), common yellowthroats (*Geothlypis trichas*), and turkey (*Meleagris gallopavo*) can be found in herbaceous wetlands within the project area. Also found are beaver signs and various frogs, such as leopard frogs (*Rana utricularia*) and gray tree frogs.

Table 4-8. Habitat Variable Measurements at Herbaceous Wetland Sites

Lake Eastex HEP Field Data Summary									
Cover Type: Herbaceous Wetland									
<i>Species: Swamp Rabbit, Green Heron, Wood Duck</i>									
Variable	Area/Site Number								Avg
	7E	8C	9F	10A	10B	10D	13A	14B	
% herbaceous canopy cover	100	100	85	95	100	98	80	100	95
% herbaceous canopy cover (herbaceous wetland)	100	100	85	95	100	98	26	100	88
Average height of herbaceous canopy	1.5	16	1.5	1.5	2.5	1.8	1.7	1.8	3.5
% tree (>16.5 ft height) canopy closure	0	0	3	0	0	0	20	5	4
% shrub (<16.5 ft height) canopy closure	0	0	7	10	23	0	15	0	7
Water regime (average summer conditions)	2	1	2	3	3	2	3	2	2
% water surface obstruction	0	0	90	0	0	0	3	0	12
% canopy of overstory trees	0	0	1	0	0	0	26	NA	4
% herbaceous canopy 6-24" tall	70	90	3	85	55	46	75	90	64
# of trees >20" dbh/acre	0	0	0	0	0	0	0	0	0
# of woody stems (>1 m tall) per acre	1	0	40	130	350	0	150	350	128
Density of potential nest cavities per acre	0	0	180	50	0	0	10	0	30
# of nest boxes/acre	0	0	0	0	0	0	0	0	0
# of potential nest sites per acre	0	0	180	50	15	0	10	0	32
% of water surface covered by potential winter cover	0	0	70	95	90	5	55	1	40
% of water surface covered by potential brood cover	0	0	80	80	95	10	75	0	43
Distance to deciduous forested or deciduous shrub wetland (miles)	0.25	0.25	0.25	0.25	0.25	0.25	0.25	0.25	0.25

Riverine

RIVERINE
(USFWS 1980)

Include streams, creeks, and rivers

Not dominated by woody or herbaceous vegetation.

May also include streams within the banks of a braided stream system

Vegetation that overhangs the banks of Mud Creek is likely to include herbs and grasses such as sedges, smartweed, and Indian sea-oats (*Chasmanthium latifolia*), as well as tree and shrub species, such as planer-tree (*Planera aquatica*), water oak, swamp privet (*Forestiera acuminata*), and water tupelo. Emergent, floating, and submerged aquatic vegetation is notably absent from the Mud Creek channel, likely due to the high water turbidity and scouring effects of flowing water. Complete results of HEP field measurements for this cover type are shown in Table 4-9. There are

approximately 195 acres of the Riverine cover type in the proposed Lake Eastex conservation pool area.

Table 4-9. Habitat Variable Measurements at Riverine Sites.

Lake Eastex HEP Field Data Summary								
Cover Type: Riverine								
Species: Green Heron, Belted Kingfisher, Wood Duck								
Variable	Area/Site Number							Avg
	4A	4B	5A	5D	7C	8D	14G	
% herbaceous canopy cover (forested Wetland)	68	85	55	70	1	10	5	42
% herbaceous canopy cover (herbaceous wetland)	NA	NA	35	35	NA	NA	NA	35
Average height of herbaceous canopy	1.0	1.0	1.0	0.9	0.3	0.4	0.4	0.7
% tree (>16.5 ft height) canopy closure	98	63	85	81	98	99	100	89
% shrub (<16.5 ft height) crown cover	50	65	55	50	30	35	60	49
Water regime (average summer conditions)	3	3	3	3	3	3	3	3
% shoreline subject to severe wave action	0	0	0	0	0	0	0	0
Water turbidity	2	3	2	3	3	3	2	3
% water surface obstruction	4	4	35	10	25	30	10	17
% water that is < 24 " in depth	20	10	40	20	100	10	100	43
% riffles	0	0	0	0	0	0	0	0
Availability of perch sites	5	5	5	5	5	5	5	5
Distance to nearest suitable soil bank from 1-km sections of lentic shoreline or stream	0	0	0	0	0	0	0	0
Aquatic substrate composition in littoral zone	1	1	1	1	1	1	1	1
% water area <10 in deep	15	10	18	30	90	3		28
% emergent herbaceous canopy cover in littoral zone	5	2	0	0	1	0	10	3
Water current (average summer conditions)	2	2	2	2	2	2	2	2
Miles to deciduous forested or deciduous shrub wetland	0.3	0.3	0.3	0.3	0.3	0.3	0.3	0.3
Density of potential nest cavities per acre	30	30	20	20	10	30		23
# of nest boxes per acre	0	0	0	0	0	0		0
# of potential nest sites per acre	30	30	20	20	10	30	20	23
% of water surface covered by potential winter cover	25	25	25	25	25	25	25	25
% of water surface covered by potential brood cover	25	50	25	25	25	25	25	29

Lacustrine

Open water areas classified as lacustrine are lentic waters (ponds, lakes, and reservoirs) that are not dominated by woody or herbaceous vegetation and are at least 20 surface acres in size (USFWS 1980). This includes areas typically referred to as open water, but does not include portions of lakes, ponds, or reservoirs that are dominated by vegetation. There are no areas of open water in the proposed Lake Eastex project area that can be considered lacustrine by the above definition.

Urban

Urban areas receive intensive use and have significant structural coverage (USFWS 1980). The urban cover type areas in the proposed Lake Eastex conservation pool are associated with private, rural properties and cover approximately 14 acres.

4.3.7 Baseline Habitat Suitability Indices

After species selection, cover types were sampled for the appropriate habitat variables required for each species' HSI model (Tables 4-3 through 4-9). The sampling site locations illustrated relative to cover types in Figures 4-8a through 4-8g are shown in more detail on color IR aerial imagery in Figures 4-9 through 4-20.

Calculation of HSI values were performed according to standard models developed for each evaluation species. Exceptions and assumptions for each species model and the specific HSI calculations for each species evaluated by cover type are described in Appendix 4. To compute the HSI for a cover type, site measurements for each variable were averaged for each cover type and then were used in the HSI model for each species. The HSI for each cover type was calculated as the arithmetic average of all the individual species' HSIs (Table 4-10).

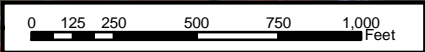
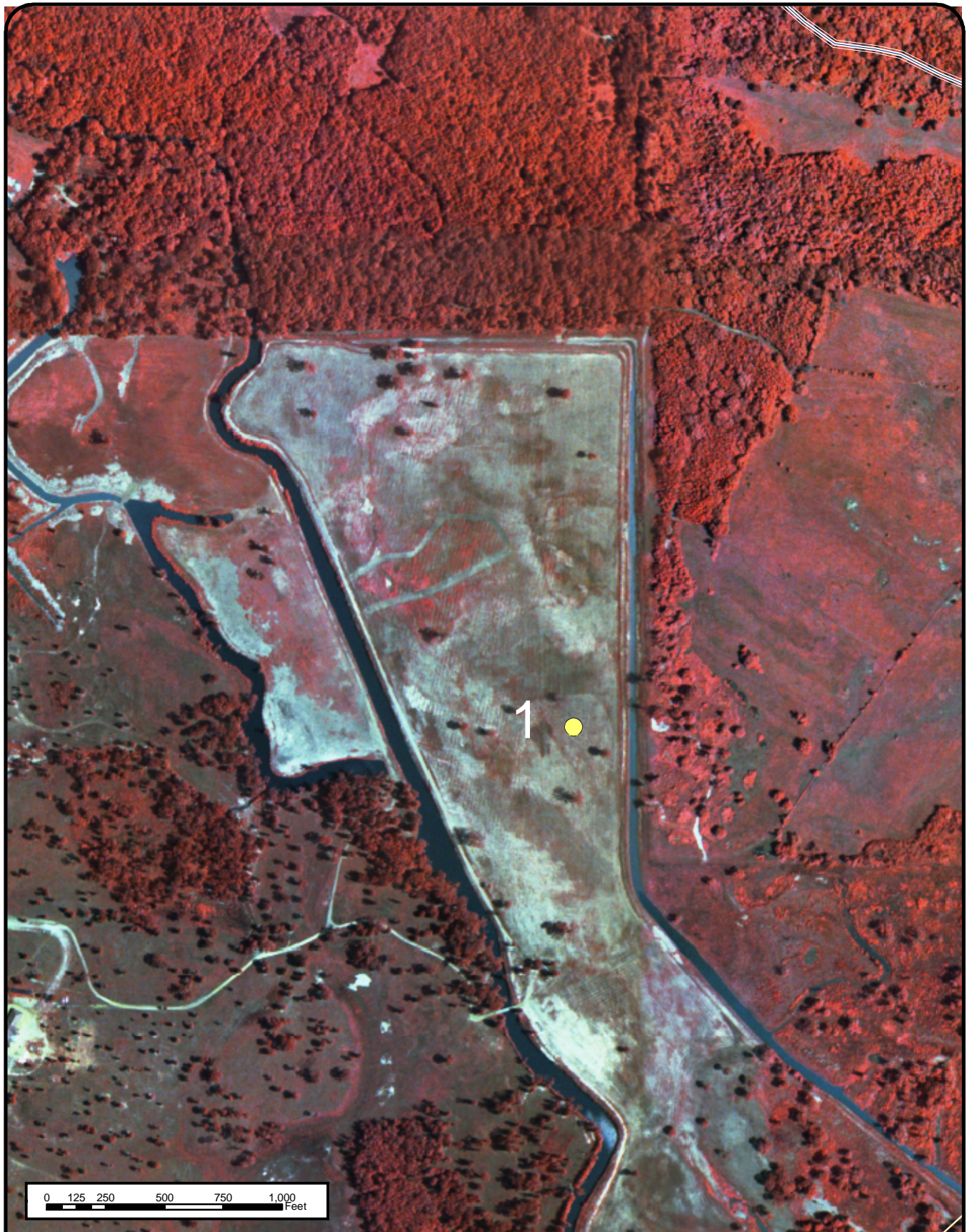

**Angelina and Neches River Authority
 Proposed Lake Eastex**

**HEP Sampling Area 1 Shown on
 Color IR (2001) Aerial Photography**

FN JOB NO	ANR01289
FILE	H:/HEP/HEP Sites-Aerial/ Sites/Site1.mxd
DATE	December 6, 2002
SCALE	1:7,000
DESIGNED	RH
DRAFTED	BAR

4-9
Figure

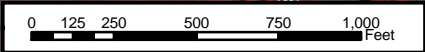
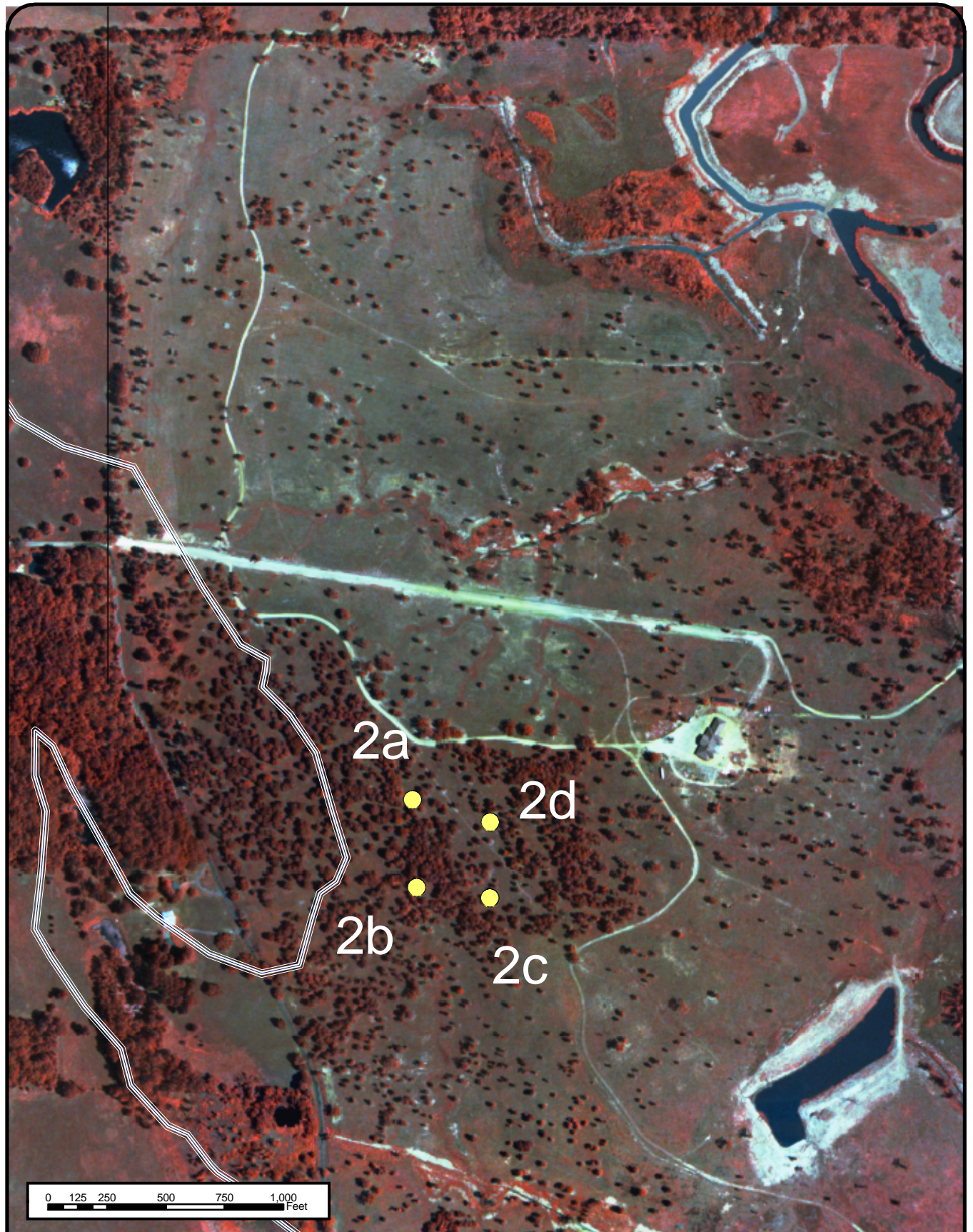

**Angelina and Neches River Authority
 Proposed Lake Eastex**

**HEP Sampling Area 2 Shown on
 Color IR (2001) Aerial Photography**

FN JOB NO	ANR01289
FILE	H:/HEP/HEP Sites-Aerial/ Sites/Site2.mxd
DATE	December 6, 2002
SCALE	1:7,000
DESIGNED	RH
DRAFTED	BAR

**4-10
 Figure**

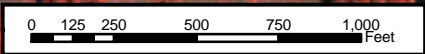
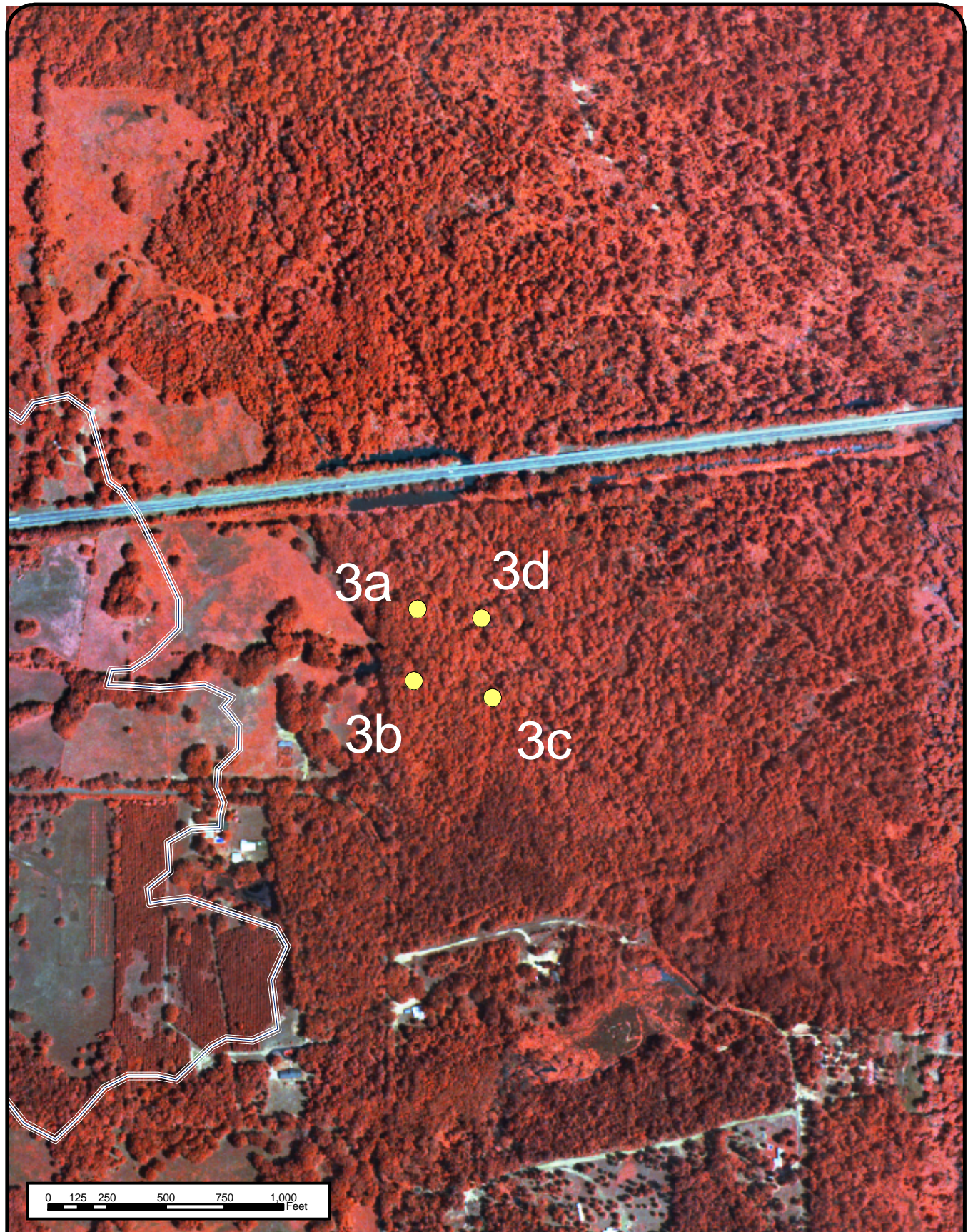

FREESE • NICHOLS
 4055 International Plaza Suite 200
 Fort Worth, Texas 76109-4895
 817-735-7300



**Angelina and Neches River Authority
 Proposed Lake Eastex**

**HEP Sampling Area 3 Shown on
 Color IR (2001) Aerial Photography**

FN JOB NO	ANR01289
FILE	H:\HEP\HEP Sites-Aerial\ Sites\Site3.mxd
DATE	December 6, 2002
SCALE	1:7,000
DESIGNED	RH
DRAFTED	BAR

4-11
 Figure

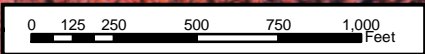
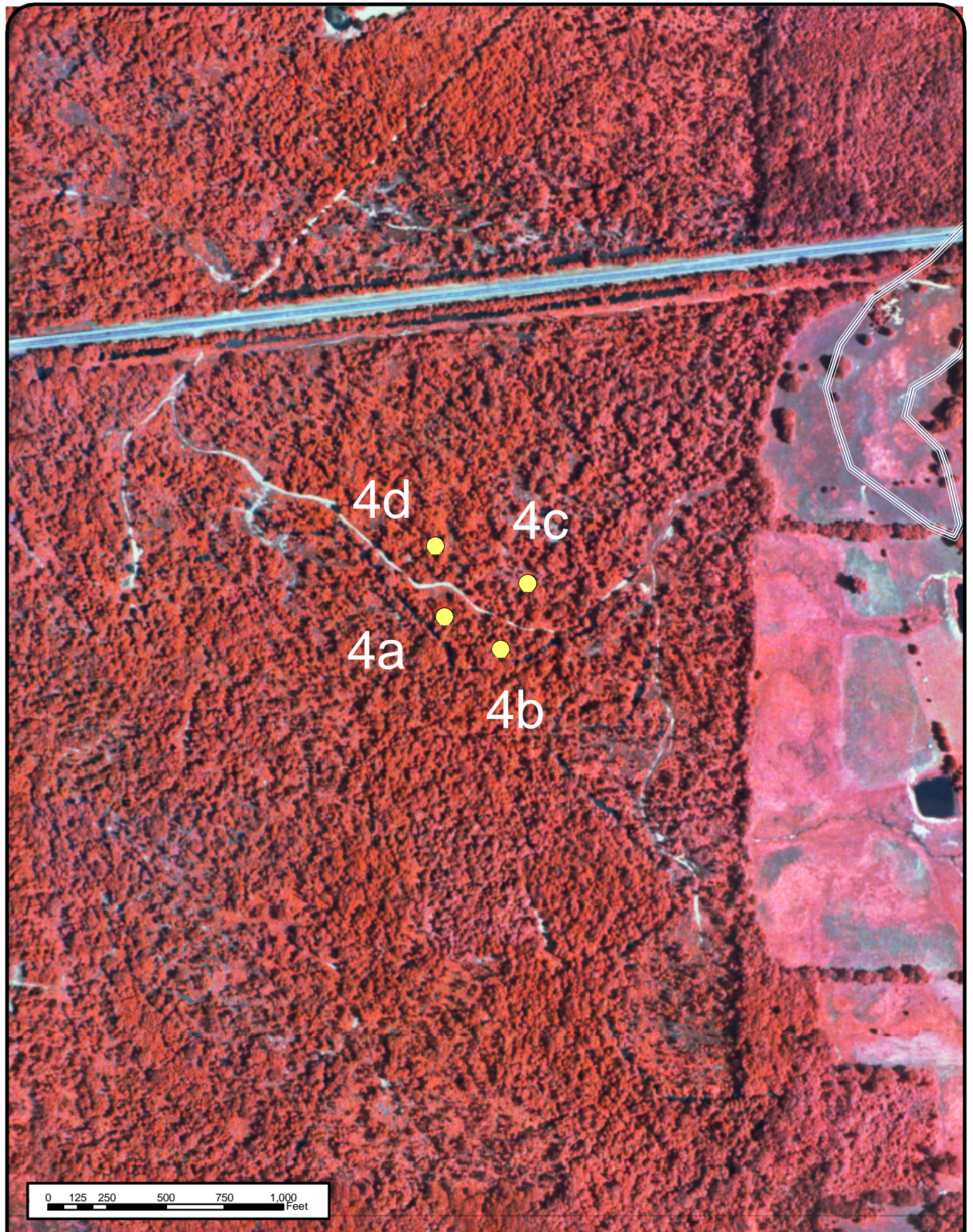

FREESSE • NICHOLS
 4055 International Plaza Suite 200
 Fort Worth, Texas 76109-4895
 817-735-7300



**Angelina and Neches River Authority
 Proposed Lake Eastex**

**HEP Sampling Area 4 Shown on
 Color IR (2001) Aerial Photography**

FN JOB NO	ANR01289
FILE	H:/HEP/HEP Sites-Aerial/ Sites/Site4.mxd
DATE	December 6, 2002
SCALE	1:7,000
DESIGNED	RH
DRAFTED	BAR

4-12
Figure

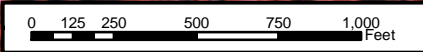
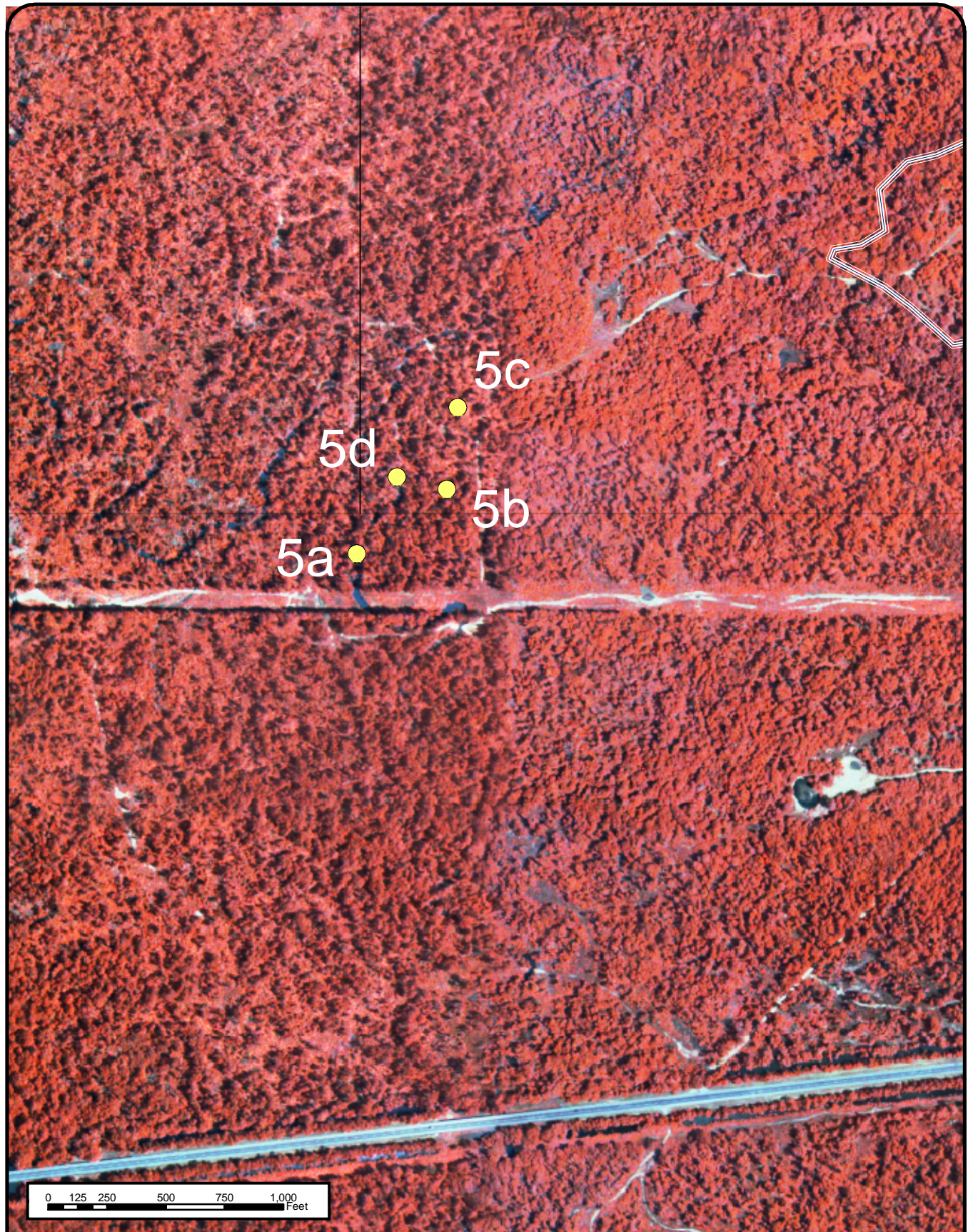

FREESE • NICHOLS
 4055 International Plaza Suite 200
 Fort Worth, Texas 76109-4895
 817-735-7300



Angelina and Neches River Authority
Proposed Lake Eastex

HEP Sampling Area 5 Shown on
Color IR (2001) Aerial Photography

FN JOB NO	ANR01289
FILE	H:/HEP/HEP Sites-Aerial/Sites/Site5.mxd
DATE	December 6, 2002
SCALE	1:7,000
DESIGNED	RH
DRAFTED	BAR

4-13
Figure

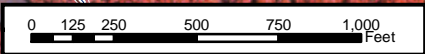
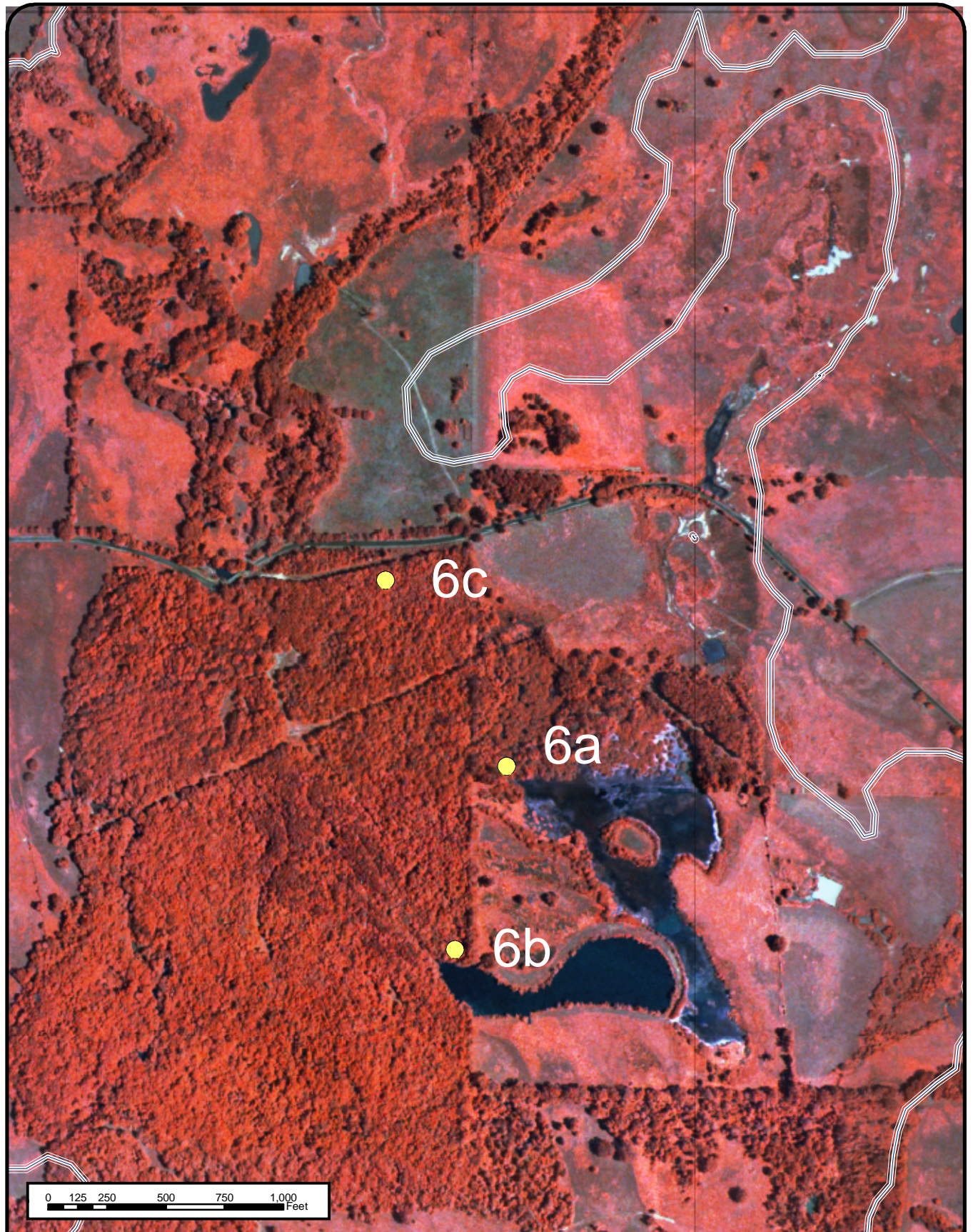



FREESE • NICHOLS
 4055 International Plaza Suite 200
 Fort Worth, Texas 76109-4895
 817-735-7300



Angelina and Neches River Authority
Proposed Lake Eastex
HEP Sampling Area 6 Shown on
Color IR (2001) Aerial Photography

FN JOB NO	ANR01289
FILE	H:/HEP/HEP Sites-Aerial/Sites/Site6.mxd
DATE	December 6, 2002
SCALE	1:7,000
DESIGNED	RH
DRAFTED	BAR

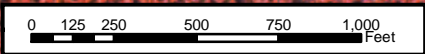
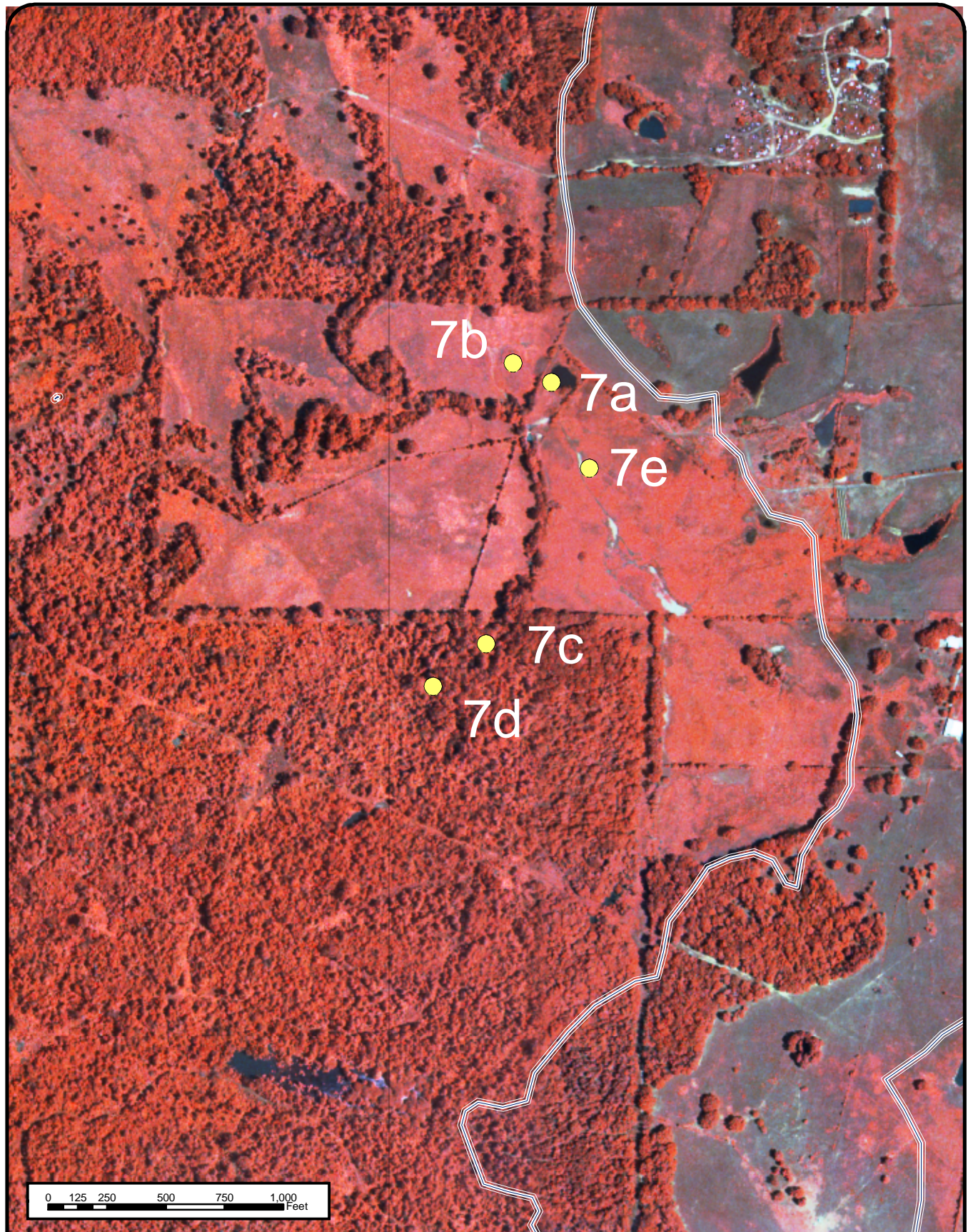
4-14
Figure



FREESE • NICHOLS
 4055 International Plaza Suite 200
 Fort Worth, Texas 76109-4895
 817-735-7300



**Angelina and Neches River Authority
 Proposed Lake Eastex**

**HEP Sampling Area 7 Shown on
 Color IR (2001) Aerial Photography**

FN JOB NO	ANR01289
FILE	H:/HEP/HEP Sites-Aerial/ Sites/Site7.mxd
DATE	December 6, 2002
SCALE	1:7,000
DESIGNED	RH
DRAFTED	BAR

**4-15
 Figure**

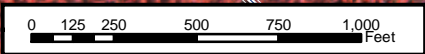
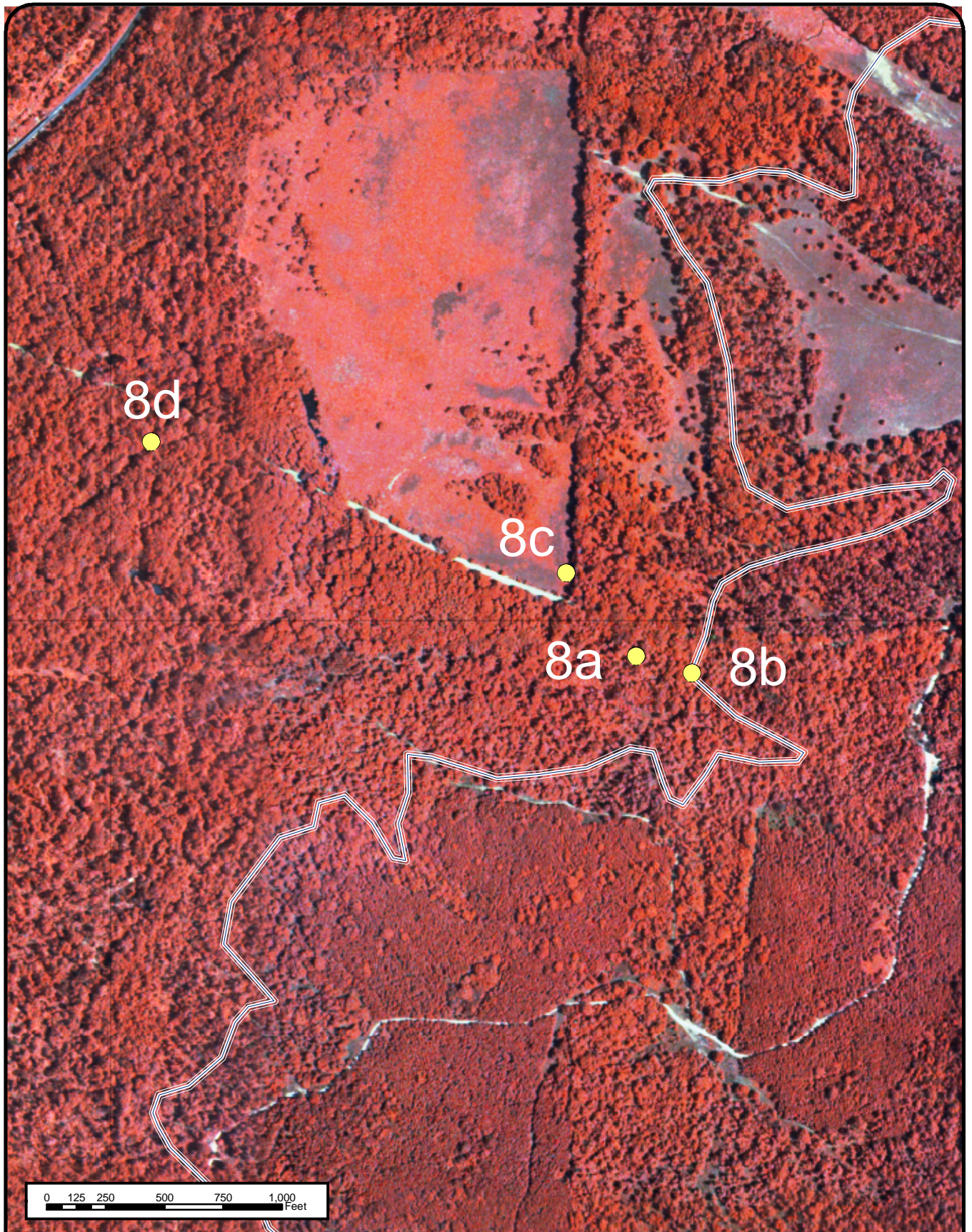

FREESE • NICHOLS
 4055 International Plaza Suite 200
 Fort Worth, Texas 76109-4895
 817-735-7300

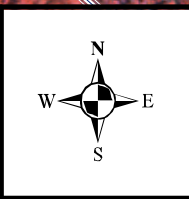

**Angelina and Neches River Authority
 Proposed Lake Eastex**

**HEP Sampling Area 8 Shown on
 Color IR (2001) Aerial Photography**

FN JOB NO	ANR01289
FILE	H:/HEP/HEP Sites-Aerial/Sites/Site8.mxd
DATE	December 6, 2002
SCALE	1:7,000
DESIGNED	RH
DRAFTED	BAR

4-16
Figure

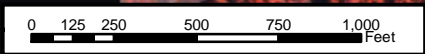
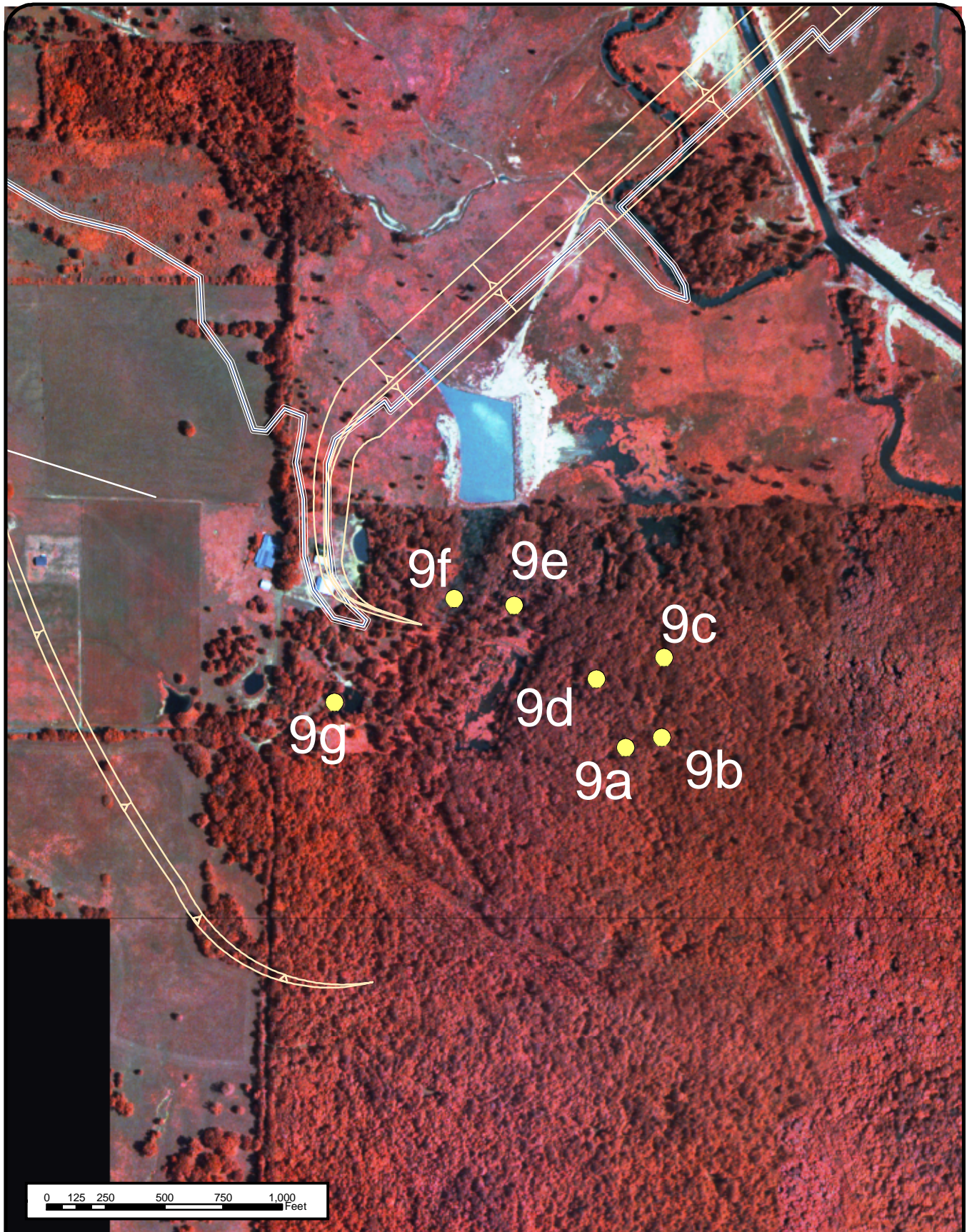

FREESE • NICHOLS
 4055 International Plaza Suite 200
 Fort Worth, Texas 76109-4895
 817-735-7300

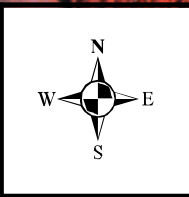

**Angelina and Neches River Authority
 Proposed Lake Eastex**

**HEP Sampling Area 9 Shown on
 Color IR (2001) Aerial Photography**

FN JOB NO	ANR01289
FILE	H:/HEP/HEP Sites-Aerial/ Sites/Site9.mxd
DATE	December 6, 2002
SCALE	1:7,000
DESIGNED	RH
DRAFTED	BAR

4-17
Figure

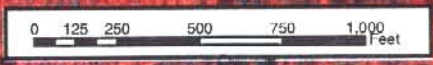
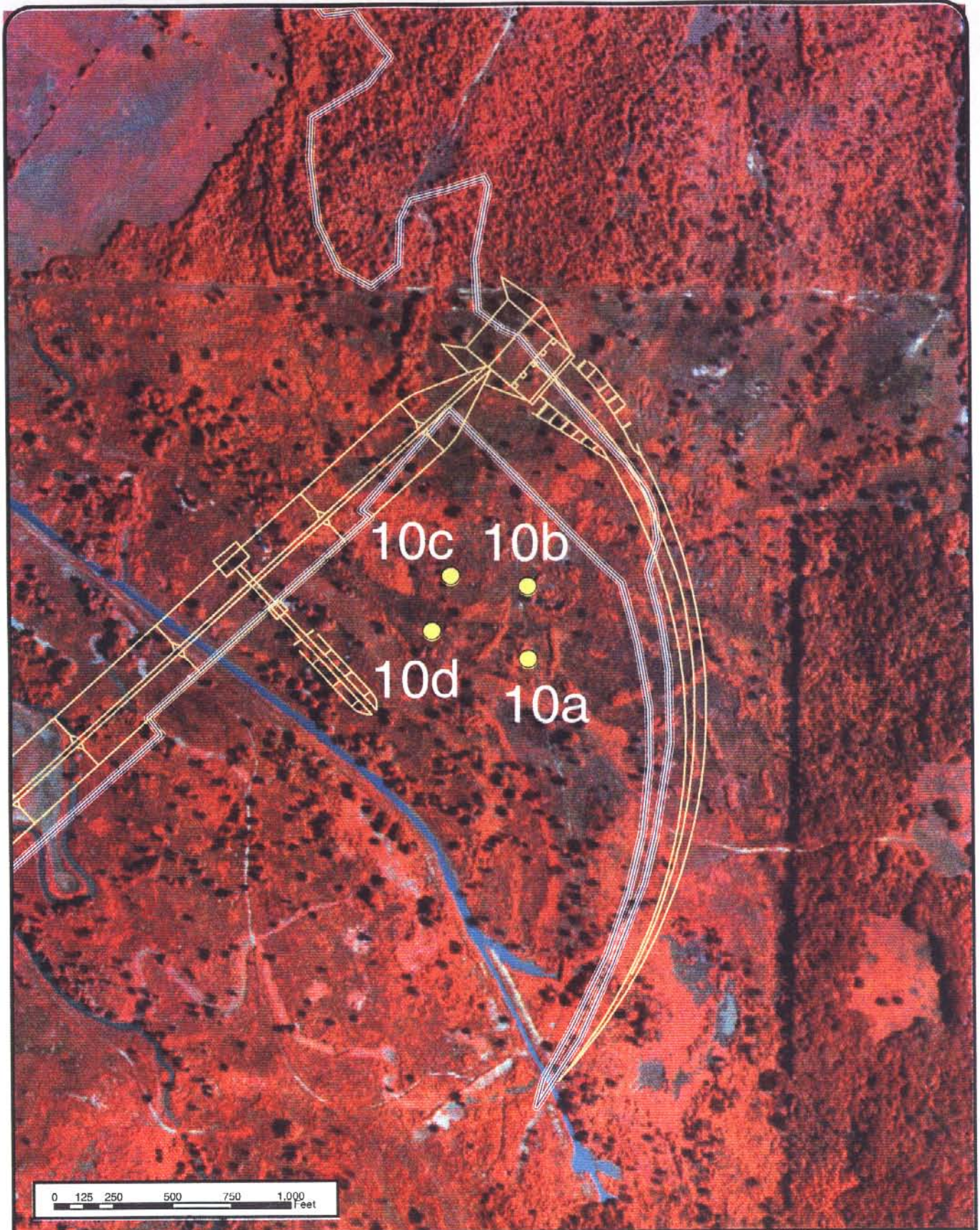

FREESE • NICHOLS
 4055 International Plaza Suite 200
 Fort Worth, Texas 76109-4895
 817-735-7300



**Angelina and Neches River Authority
 Proposed Lake Eastex**

**HEP Sampling Area 10 Shown on
 Color IR (2001) Aerial Photography**

FN JOB NO	ANR01289
FILE	H:\HEP\HEP Site-Aerial\Site\Site_10.mxd
DATE	December 6, 2002
SCALE	1:7,000
DESIGNED	RH
DRAFTED	BAR

**4-18
 Figure**

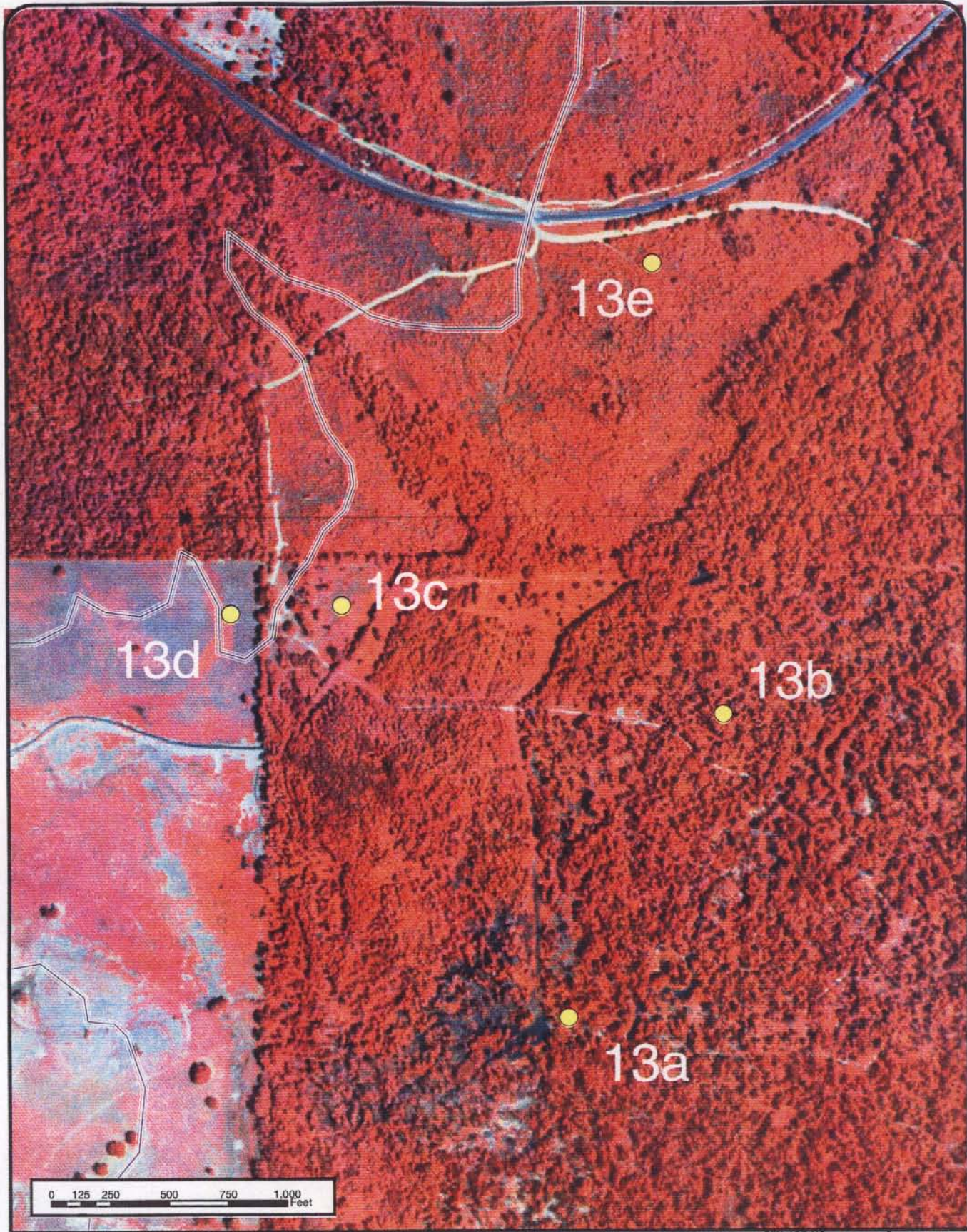

FREESE • NICHOLS
 4055 International Plaza Suite 200
 Fort Worth, Texas 76109-4895
 817-735-7300



Angelina and Neches River Authority
Proposed Lake Eastex

HEP Sampling Area 13 Shown on
Color IR (2001) Aerial Photography

FN JOB NO	ANR01289
FILE	H:\HEP\HEP Sites-Aerial Sites\Site 13.mxd
DATE	December 6, 2002
SCALE	1:7,000
DESIGNED	RH
DRAFTED	BAR

4-19
Figure

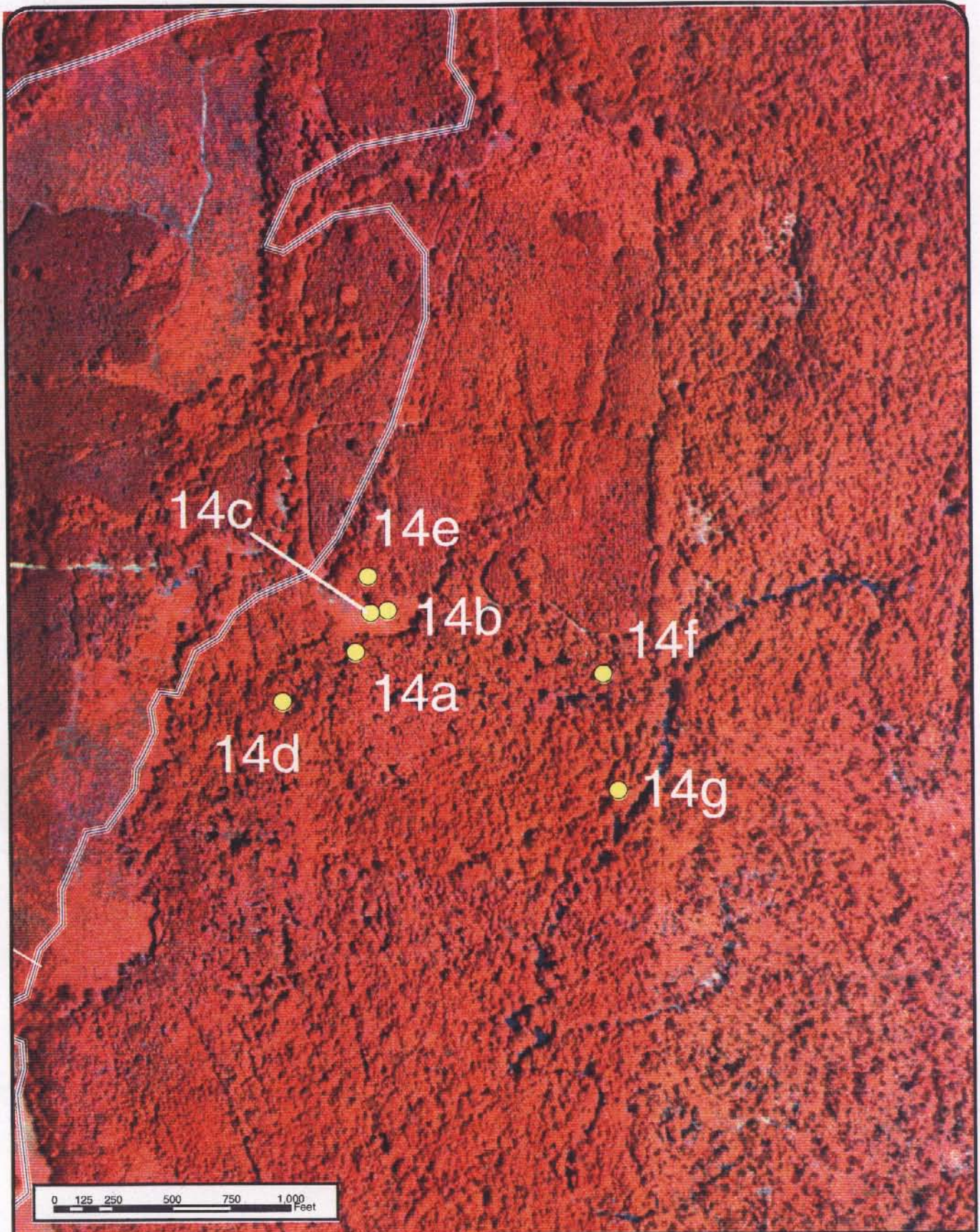

FREESE • NICHOLS
 4055 International Plaza Suite 200
 Fort Worth, Texas 76109-4895
 817-735-7300



**Angelina and Neches River Authority
 Proposed Lake Eastex**

**HEP Sampling Area 14 Shown on
 Color IR (2001) Aerial Photography**

FN JOB NO	ANR01289
FILE	H:\HEP\HEP Sites-Aerial\ Sites\Site 14.mxd
DATE	December 6, 2002
SCALE	1:7,000
DESIGNED	RH
DRAFTED	BAR

**4-20
 Figure**

Table 4-10. Habitat Suitability Indices by Cover Type

Species	Cover Type						
	Bottomland Hardwood	Upland Forest	Herbaceous Wetland	Grassland	Shrubland	Shrub Wetland	Riverine
Racer	~	~	~	~	1.00	~	~
Eastern Meadowlark	~	~	~	0.71	~	~	~
Eastern Cottontail	~	0.73	~	0.73	0.73	~	~
Swamp Rabbit	0.51	~	0.50	~	~	0.49	~
Green Heron	0.55	~	0.90	~	~	0.90	0.95
Wood Duck	0.68	~	0.68	~	~	0.68	0.68
Belted Kingfisher	~	~	~	~	~	~	0.34
Fox Squirrel	0.69	0.68	~	~	~	~	~
Gray Squirrel	0.69	0.57	~	~	~	~	~
Downy Woodpecker	0.86	1.00	~	~	~	~	~
Barred Owl	0.70	0.65	~	~	~	~	~
Red-tailed Hawk	~	0.84	~	0.84	0.84	~	~
Average HSI Values	0.67	0.75	0.69	0.76	0.86	0.69	0.66

4.3.8 Baseline Habitat Units

Baseline Habitat Units (HUs) were calculated for each cover type within the Lake Eastex project area by multiplying the average cover type Habitat Suitability Index (HSI) values (Table 4-10) by the cover type acreage (Table 4-11).

Table 4-11. Baseline Habitat Units by Cover Type.

Cover Type	Average HSI	Area (acres)	Habitat Units (HUs)
Bottomland Hardwood	0.67	3652.6	2442.0
Upland Forest	0.75	2181.6	1625.3
Herbaceous Wetland	0.69	1349.5	935.6
Grassland	0.76	2188.9	1663.6
Shrubland	0.86	189.7	162.5
Shrub Wetland	0.69	132.8	91.6
Riverine	0.66	297.0	195.1

4.3.9 Future Habitat Units

Habitat units were calculated for each of the cover types at future points in time for “future-with” and “future-without” the Lake Eastex project. The habitat conditions in the baseline year were compared to future target years (10, 20, 50, and 100 years).

The HEP team developed and reached consensus on the assumptions to base the predictions of future conditions for each cover type in the Lake Eastex conservation pool area. These assumptions were based in part on interviews of knowledgeable residents and resource professionals in the Cherokee County area who are familiar with local land-use issues; published literature; and the professional judgment of HEP Team members. In general, the causes for cover type changes included natural successional transitions from one cover type to another; cover type conversions due to silviculture activities; clearing for pastureland; and urbanization. The amount of urbanization was assumed to be minimal over the next 100 years. It was also assumed that habitat quality (HSI values) per cover type, as quantified by the HEP baseline analysis, would remain unchanged for the next 100 years. The assumptions are summarized below for each cover type and quantified in Table 4-12.

Herbaceous Wetland

Some of the existing herbaceous wetland in the project area will transition in the short term to shrub wetland through natural succession. In the long term, a portion of herbaceous wetland will transition into bottomland hardwood forest, with an intermediary shrub wetland successional phase.

Shrub Wetland

A proportion of the existing shrub wetland in the project area will be converted through natural succession to bottomland hardwood forest every year over the next one hundred years. Some herbaceous wetland will transition into shrub wetland, which will in turn transition into bottomland hardwood forest.

Table 4-12. Predicted Changes in Cover Types Acreages without Lake Eastex

Bottomland Hardwood (BLH)												
Baseline Area	Conversion		Years Beyond Baseline									
	From	To	10		20		50		100			
	% Change	Area Change	% Change	Area Change	% Change	Area Change	% Change	Area Change	% Change	Area Change		
3653	BLH	SW	-0.05	-183	-0.05	-183	-0.10	-365	0.00	0		
190	SW	BLH	0.30	57	0.30	57	0.25	47	0.00	0		
1350	HW	BLH	0.00	0	0.10	135	0.35	472	0.00	0		
		Net Change		-126		9		154		0		
		Total Area (acres)		3527		3536		3691		3691		
										Net Change From Baseline (acres)		38
Shrub Wetland (SW)												
Baseline Area	Conversion		Years Beyond Baseline									
	From	To	10		20		50		100			
	% Change	Area Change	% Change	Area Change	% Change	Area Change	% Change	Area Change	% Change	Area Change		
133	SW	BLH	-0.30	-40	-0.30	-40	-0.25	-33	0.00	0		
1350	HW	SW	0.10	135	0.10	135	0.20	270	0.00	0		
3653	BLH	SW	0.05	183	0.05	183	0.10	365	0.00	0		
		Net Change		278		278		602		0		
		Total Area (acres)		411		688		1290		1290		
										Net Change From Baseline (acres)		1157
Herbaceous Wetland (HW)												
Baseline Area	Conversion		Years Beyond Baseline									
	From	To	10		20		50		100			
	% Change	Area Change	% Change	Area Change	% Change	Area Change	% Change	Area Change	% Change	Area Change		
1350	HW	SW	-0.10	-135	-0.10	-135	-0.20	-270	0.00	0		
1350	HW	BLH	0.00	0	-0.10	-135	-0.35	-472	0.00	0		
		Net Change		-135		-270		-742		0		
		Total Area (acres)		1215		945		202		202		
										Net Change From Baseline (acres)		-1147
Upland Forest (UF)												
Baseline Area	Conversion		Years Beyond Baseline									
	From	To	10		20		50		100			
	% Change	Area Change	% Change	Area Change	% Change	Area Change	% Change	Area Change	% Change	Area Change		
2182	UF	G	-0.01	-22	-0.01	-22	-0.02	-44	-0.02	-44		
2182	UF	S	-0.10	-218	-0.10	-218	-0.10	-218	-0.10	-218		
2182	UF	U	-0.01	-22	-0.01	-22	-0.03	-65	-0.03	-65		
2189	G	UF	0.03	66	0.03	66	0.20	438	0.20	438		
190	S	UF	0.10	19	0.10	19	0.10	19	0.10	19		
		Net Change		-177		-177		130		130		
		Total Area (acres)		2004		1827		1957		2086		
										Net Change From Baseline (acres)		-95
Shrub Upland (S)												
Baseline Area	Conversion		Years Beyond Baseline									
	From	To	10		20		50		100			
	% Change	Area Change	% Change	Area Change	% Change	Area Change	% Change	Area Change	% Change	Area Change		
190	S	G	0.00	0	0.00	0	0.00	0	0.00	0		
190	S	UF	-0.10	-19	-0.10	-19	-0.10	-19	-0.10	-19		
190	S	U	-0.01	-2	-0.01	-2	-0.03	-6	-0.05	-9		
2182	UF	S	0.10	218	0.10	218	0.10	218	0.10	218		
2189	G	S	0.05	109	0.05	109	0.05	109	0.05	109		
		Net Change		307		307		303		299		
		Total Area (acres)		496		803		1106		1405		
										Net Change From Baseline (acres)		1216
Grassland (G)												
Baseline Area	Conversion		Years Beyond Baseline									
	From	To	10		20		50		100			
	% Change	Area Change	% Change	Area Change	% Change	Area Change	% Change	Area Change	% Change	Area Change		
2189	G	S	-0.05	-109	-0.05	-109	-0.05	-109	-0.05	-109		
2189	G	UF	-0.03	-66	-0.03	-66	-0.20	-438	-0.20	-438		
2189	G	U	-0.01	-22	-0.01	-22	-0.03	-66	-0.05	-109		
190	S	G	0.00	0	0.00	0	0.00	0	0.00	0		
2182	UF	G	0.01	22	0.01	22	0.02	44	0.02	44		
		Net Change		-175		-175		-569		-613		
		Total Area (acres)		2014		1839		1269		656		
										Net Change From Baseline (acres)		-1533

Bottomland Hardwood Forest (Deciduous Forested Wetland)

A small fraction of the existing bottomland hardwood forest will be converted to shrub wetland every year over the next one hundred years due to tree harvesting and clearing for pasture.

Riverine

It was assumed that without the proposed project there would be no net changes in the amount of riverine cover type, which consists of Mud Creek and its tributaries.

Grassland

In the short term, a portion of the existing grasslands in the project area will transition into shrubland through natural succession. In the long term, a fraction of the grassland will transition into upland forest, with an intermediary shrubland successional phase. A small portion of existing grasslands will likely become urbanized over time.

Shrubland (Shrub Upland)

Shrubland in the proposed Lake Eastex project area is essentially a transitional stage caused by either abandonment of grassland/pastureland or by silviculture methods of forest regeneration (i.e., clear-cutting and planting).

A proportion of the existing shrubland in the project area will transition into upland forest over time due to natural succession. As new shrubland is created from the natural succession of grassland, a portion of the new shrubland will transition into upland forest in the long term.

Upland Forest

It is assumed that the upland forest will consist primarily of mixed pine-hardwood tree species. A small proportion of shrubland will transition into upland forest through natural succession. It is also likely that a small portion of upland forest will become urbanized.

For the purposes of this analysis, it was assumed that all cover types would be converted to lacustrine habitat with the Lake Eastex Project. In reality, some of the conservation pool area

would probably develop into some of the more flood tolerant habitats such as shrub wetland and herbaceous wetland.

Using the above data, the annualized habitat units for each cover type were calculated for “with project” and “without project” conditions using “Form C” of the HEP accounting procedure. Results of these calculations are show in Tables 4-13 through 4-19. The net losses of habitat units for each cover type (Table 4-20) can be used to plan for and estimate potential mitigation requirements needed to compensate for wildlife habitat functions.

Table 4-13. Deciduous Forested Wetland Form C - Calculation of Average Annual Habitat Units

With Lake Eastex													
1. Study		2. Study Area						3. Proposed Action					
4. Evaluation Species		5. HSI and area by Target Year (TY)											
DFW (BLH)		Baseline (TY0)		TY1		TY1		TY		TY		TY	
HIS Value		HSI	Area	HSI	Area	HSI	Area	HSI	Area	HSI	Area	HSI	Area
0.67		0.67	3652	0.67	3652	0	0	0	0	0	0	0	0
6. Calculations											7. Habitat Units between Target Years		
6a.		1		1631		816		2447					2447
6b.		9		816		0		7341					7341
6c.		10		0		0		0					0
6d.		30		0		0		0					0
6e.		50		0		0		0					0
6f. Total from additional Target Years											Sum of Habitat Units 8.		
											9787		
9. Life of Project		100		10. Average Annual HUs Block 8/Block 9						97.9			

Without Lake Eastex													
1. Study		2. Study Area						3. Proposed Action					
4. Evaluation Species		5. HSI and area by Target Year (TY)											
DFW (BLH)		Baseline (TY0)		TY1		TY1		TY		TY		TY	
HIS value		HSI	Area	HSI	Area	HSI	Area	HSI	Area	HSI	Area	HSI	Area
0.67		0.67	3652	0.67	3652	0.67	3526.9	0.67	3536.1	0.67	3690.1	0.67	3690.1
6. Calculations											7. Habitat Units between Target Years		
6a.		1		1631		816		2447					2447
6b.		9		1603		802		21644					21644
6c.		10		1577		789		23661					23661
6d.		30		1614		807		72623					72623
6e.		50		1648		824		123618					123618
6f. Total from additional Target Years											Sum of Habitat Units 8.		
											243994		
9. Life of Project		100		10. Average Annual HUs Block 8/Block 9						2439.9			

NET IMPACT=AAHU (With Project) - AAHU (Without Project)

= -2342.1 AAHU

Table 4-14. Shrub Wetland Form C - Calculation of Average Annual Habitat Units

With Lake Eastex

1. Study	2. Study Area						3. Proposed Action																	
4. Evaluation Species SW HSI value 0.69	5. HSI and area by Target Year (TY)																							
	Baseline (TY0)		0		TY1		1		TY1		10		TY		20		TY		50		TY		100	
	HSI	Area	HSI	Area	HSI	Area	HSI	Area	HSI	Area	HSI	Area	HSI	Area	HSI	Area	HSI	Area	HSI	Area	HSI	Area		
	0.69	132.8	0.69	132.8	0	0	0	0	0	0	0	0	0	0	0	0	0	0	0	0	0	0		
6. Calculations																					7. Habitat Units between Target Years			
6a.																					92			
6b.																					275			
6c.																					0			
6d.																					0			
6e.																					0			
6f. Total from additional Target Years																					Sum of Habitat Units 8.		367	
9. Life of Project												100	10. Average Annual HUs Block 8/Block 9						3.7					

Without Lake Eastex

1. Study	2. Study Area						3. Proposed Action																	
4. Evaluation Species BLH HIS value 0.69	5. HSI and area by Target Year (TY)																							
	Baseline (TY0)		0		TY1		1		TY1		10		TY		20		TY		50		TY		100	
	HSI	Area	HSI	Area	HSI	Area	HSI	Area	HSI	Area	HSI	Area	HSI	Area	HSI	Area	HSI	Area	HSI	Area	HSI	Area		
	0.69	132.8	0.69	132.8	0.69	410.5	0.69	688.3	0.69	1290.2	0.69	1290.2	0.69	1290.2	0.69	1290.2	0.69	1290.2	0.69	1290.2	0.69	1290.2		
6. Calculations																					7. Habitat Units between Target Years			
6a.																					92			
6b.																					1687			
6c.																					3791			
6d.																					20477			
6e.																					44512			
6f. Total from additional Target Years																					Sum of Habitat Units 8.		70559	
9. Life of Project												100	10. Average Annual HUs Block 8/Block 9						705.6					

NET IMPACT=AAHU (With Project) - AAHU (Without Project)

= -701.9 AAHU

Table 4-15. Herbaceous Wetland Form C - Calculation of Average Annual Habitat Units

With Lake Eastex

1. Study		2. Study Area						3. Proposed Action						
4. Evaluation Species		5. HSI and area by Target Year (TY)												
HW	HSI value 0.69	Baseline (TY0)		TY1		TY1		TY 20		TY 50		TY 100		
		HSI	Area	HSI	Area	HSI	Area	HSI	Area	HSI	Area	HSI	Area	
		0.69	1349.5	0.69	1349.5	0	0	0	0	0	0	0	0	
6. Calculations												7. Habitat Units between Target Years		
6a.		1				621	310	931					931	
6b.		9				310	0	2793					2793	
6c.		10				0	0	0					0	
6d.		30				0	0	0					0	
6e.		50				0	0	0					0	
6f. Total from additional Target Years												Sum of Habitat Units 8.		
												3725		
9. Life of Project		100						10. Average Annual HUs Block 8/Block 9						37.2

Without Lake Eastex

1. Study		2. Study Area						3. Proposed Action						
4. Evaluation Species		5. HSI and area by Target Year (TY)												
HW	HSI value 0.69	Baseline (TY0)		TY1		TY1		TY 20		TY 50		TY 100		
		HSI	Area	HSI	Area	HSI	Area	HSI	Area	HSI	Area	HSI	Area	
		0.69	1349.5	0.69	1349.5	0.69	1214.6	0.69	944.7	0.69	202.4	0.69	202.43	
6. Calculations												7. Habitat Units between Target Years		
6a.		1				621	310	931					931	
6b.		9				590	295	7962					7962	
6c.		10				497	248	7450					7450	
6d.		30				264	132	11872					11872	
6e.		50				93	47	6983					6983	
6f. Total from additional Target Years												Sum of Habitat Units 8.		
												35198		
9. Life of Project		100						10. Average Annual HUs Block 8/Block 9						352.0

NET IMPACT=AAHU (With Project) - AAHU (Without Project)

= -314.7 AAHU

Table 4-16. Upland Forest Form C - Calculation of Average Annual Habitat Units

With Lake Eastex

1. Study		2. Study Area						3. Proposed Action																			
4. Evaluation Species		5. HSI and area by Target Year (TY)																									
UF	HSI value 0.75	Baseline (TY0)		0		TY1		1		TY1		10		TY		20		TY		50		TY		100			
		HSI	Area	HSI	Area	HSI	Area	HSI	Area	HSI	Area	HSI	Area	HSI	Area	HSI	Area	HSI	Area	HSI	Area	HSI	Area	HSI	Area		
		0.75	2181.6	0.75	2181.6	0	0	0	0	0	0	0	0	0	0	0	0	0	0	0	0	0	0	0	0		
6. Calculations																						7. Habitat Units between Target Years					
6a.		1		1091		545		1636																1636			
6b.		9		545		0		4909																4909			
6c.		10		0		0		0																0			
6d.		30		0		0		0																0			
6e.		50		0		0		0																0			
6f. Total from additional Target Years																						Sum of Habitat Units		8.		6545	
9. Life of Project		100												10. Average Annual HUs		65.4											
														Block 8/Block 9													

Without Lake Eastex

1. Study		2. Study Area						3. Proposed Action																			
4. Evaluation Species		5. HSI and area by Target Year (TY)																									
UF	HSI value 0.75	Baseline (TY0)		0		TY1		1		TY1		10		TY		20		TY		50		TY		100			
		HSI	Area	HSI	Area	HSI	Area	HSI	Area	HSI	Area	HSI	Area	HSI	Area	HSI	Area	HSI	Area	HSI	Area	HSI	Area	HSI	Area		
		0.75	2181.6	0.75	2181.6	0.75	2004.5	0.75	1827.3	0.75	1956.8	0.75	2086.31														
6. Calculations																						7. Habitat Units between Target Years					
6a.		1		1091		545		1636																1636			
6b.		9		1047		523		14128																14128			
6c.		10		958		479		14369																14369			
6d.		30		946		473		42571																42571			
6e.		50		1011		505		75808																75808			
6f. Total from additional Target Years																						Sum of Habitat Units		8.		148513	
9. Life of Project		100												10. Average Annual HUs		1485.1											
														Block 8/Block 9													

NET IMPACT=AAHU (With Project) - AAHU (Without Project)

= -1419.7 AAHU

Table 4-17. Shrub Upland Form C - Calculation of Average Annual Habitat Units

With Lake Eastex

1. Study		2. Study Area						3. Proposed Action					
4. Evaluation Species		5. HSI and area by Target Year (TY)											
SU HSI value 0.86		Baseline (TY0)		TY1		TY1		TY		TY		TY	
		HSI	Area	HSI	Area	HSI	Area	HSI	Area	HSI	Area	HSI	Area
		0.86	189.7	0.86	189.7	0	0	0	0	0	0	0	0
6. Calculations												7. Habitat Units between Target Years	
6a.	1				109	54	163						163
6b.	9				54	0	489						489
6c.	10				0	0	0						0
6d.	30				0	0	0						0
6e.	50				0	0	0						0
6f. Total from additional Target Years												Sum of Habitat Units 8.	
												653	
9. Life of Project		100		10. Average Annual HUs Block 8/Block 9						6.5			

Without Lake Eastex

1. Study		2. Study Area						3. Proposed Action					
4. Evaluation Species		5. HSI and area by Target Year (TY)											
SU HIS value 0.86		Baseline (TY0)		TY1		TY1		TY		TY		TY	
		HSI	Area	HSI	Area	HSI	Area	HSI	Area	HSI	Area	HSI	Area
		0.86	189.7	0.86	189.7	0.86	496.44	0.86	803.2	0.86	1106.1	0.86	1405.3
6. Calculations												7. Habitat Units between Target Years	
6a.	1				109	54	163						163
6b.	9				197	98	2655						2655
6c.	10				373	186	5588						5588
6d.	30				547	274	24630						24630
6e.	50				720	360	53995						53995
6f. Total from additional Target Years												Sum of Habitat Units 8.	
												87032	
9. Life of Project		100		10. Average Annual HUs Block 8/Block 9						870.3			

NET IMPACT=AAHU (With Project) - AAHU (Without Project)

= -863.8 AAHU

Table 4-18. Grassland Form C - Calculation of Average Annual Habitat Units

With Lake Eastex

1. Study		2. Study Area						3. Proposed Action																					
4. Evaluation Species		5. HSI and area by Target Year (TY)																											
G		Baseline (TY0)		0		TY1		1		TY1		10		TY		20		TY		50		TY		100					
HSI value 0.76		HSI		Area		HSI		Area		HSI		Area		HSI		Area		HSI		Area		HSI		Area					
		0.76		2188.9		0.76		2188.9		0		0		0		0		0		0		0		0					
6. Calculations																							7. Habitat Units between Target Years						
6a.		1				1109		555		1664														1664					
6b.		9				555		0		4991														4991					
6c.		10				0		0		0														0					
6d.		30				0		0		0														0					
6e.		50				0		0		0														0					
6f. Total from additional Target Years																							Sum of Habitat Units 8.		6654				
9. Life of Project		100																								10. Average Annual HUs Block 8/Block 9		66.5	

Without Lake Eastex

1. Study		2. Study Area						3. Proposed Action																							
4. Evaluation Species		5. HSI and area by Target Year (TY)																													
G		Baseline (TY0)		0		TY1		1		TY1		10		TY		20		TY		50		TY		100							
HIS value 0.76		HSI		Area		HSI		Area		HSI		Area		HSI		Area		HSI		Area		HSI		Area							
		0.76		2188.9		0.76		2188.9		0.76		2013.7		0.76		1838.5		0.76		1269.2		0.76		656.2							
6. Calculations																							7. Habitat Units between Target Years								
6a.		1				1109		555		1664																1664					
6b.		9				1065		532		14373																14373					
6c.		10				976		488		14638																14638					
6d.		30				787		394		35428																35428					
6e.		50				488		244		36583																36583					
6f. Total from additional Target Years																							Sum of Habitat Units 8.		102685						
9. Life of Project		100																										10. Average Annual HUs Block 8/Block 9		1026.9	

NET IMPACT=AAHU (With Project) - AAHU (Without Project)

= -960.3 AAHU

Table 4-19. Riverine Form C - Calculation of Average Annual Habitat Units

With Lake Eastex

1. Study		2. Study Area						3. Proposed Action																	
4. Evaluation Species		5. HSI and area by Target Year (TY)																							
Riverine HSI value 0.66	Baseline (TY0)	0		TY1		1		TY1		10		TY		20		TY		50		TY		100			
	HSI	Area		HSI		Area		HSI		Area		HSI		Area		HSI		Area		HSI		Area			
	0.66	297		0.66		297		0		0		0		0		0		0		0		0			
6. Calculations																				7. Habitat Units between Target Years					
6a.		1				131		65		196												196			
6b.		9						65		0		588										588			
6c.		10				0		0		0												0			
6d.		30				0		0		0												0			
6e.		50				0		0		0												0			
6f. Total from additional Target Years		Sum of Habitat Units 8.																				784			
9. Life of Project		100		10. Average Annual HUs Block 8/Block 9										7.8											

Without Lake Eastex

1. Study		2. Study Area						3. Proposed Action																	
4. Evaluation Species		5. HSI and area by Target Year (TY)																							
Riverine HSI value 0.66	Baseline (TY0)	0		TY1		1		TY1		10		TY		20		TY		50		TY		100			
	HSI	Area		HSI		Area		HSI		Area		HSI		Area		HSI		Area		HSI		Area			
	0.66	297		0.66		297		0.66		297		0.66		297		0.66		297		0.66		297			
6. Calculations																				RR					
6a.		1				131		65		196												196			
6b.		9				131		65		1764												1764			
6c.		10				131		65		1960												1960			
6d.		30				131		65		5881												5881			
6e.		50				131		65		9801												9801			
6f. Total from additional Target Years		Sum of Habitat Units 8.																				19602			
9. Life of Project		100		10. Average Annual HUs Block 8/Block 9										196.0											

NET IMPACT=AAHU (With Project) - AAHU (Without Project)
= -188.2 AAHU

Table 4-20. Net Impacts of Lake Eastex Project on Wildlife Habitat (AAHU)

Cover Type	Area Within Conservation Pool (acres)	Net Losses (AAHU)
Deciduous Forested Wetland	3652	2342
Grassland	2189	960
Upland Forest	2182	1420
Herbaceous Wetland	1349	315
Riverine	298	188
Shrub-scrub Upland	190	864
Shrub-scrub Wetland	133	702

References

- Allen A.W. 1984. Habitat Suitability Models: Eastern Cottontail. U.S. Department of Interior, Fish and Wildlife Service. FWS/OBS-82/10.66. 23 pp.
- Allen, A. W. 1982a. Habitat Suitability index models: fox squirrel. U.S. Dept. Int., Fish Wildl. Serv. FWS/OBS-82/10.18. 11p.
- Allen, A. W. 1982b. Habitat Suitability index models: gray squirrel. U.S. Dept. Int., Fish Wildl. Serv. FWS/OBS-82/10.19. 11p.
- Allen, A. W. 1985. Habitat Suitability index models: swamp rabbit. U.S. Dept. Int., Fish Wildl. Serv. FWS/OBS-82/107. 20p.
- Allen, A.W. 1987. Habitat Suitability Models: Barred Owl. U.S. Department of Interior, Fish and Wildlife Service. FWS/OBS-82/10.143. 17 pp.
- Author Unknown. Habitat Suitability Models: Green Heron (Review Copy). 1980. U.S. Department of Interior, Fish and Wildlife Service. 8 pp.
- Author Unknown. Habitat Suitability Models: Racer (Review Copy). 1980. U.S. Department of Interior, Fish and Wildlife Service. 6 pp.
- Author Unknown. Habitat Suitability Models: Red-tailed Hawk (Review Copy). 1980. U.S. Department of Interior, Fish and Wildlife Service. 14 pp.
- Hicks and Company. 1994a. *Guidance Plan for Wetland Delineation at the Proposed Lake Eastex, Cherokee and Smith Counties, Texas*. Austin, Texas.
- Hicks and Company. 1994b. *Draft Report of Investigations Section 404 Wetland Delineation of the Proposed Lake Eastex, Cherokee and Smith Counties, Texas*. Austin, Texas.
- Lockwood, Andrews & Newman, Inc. (LAN) 1991 *Lake Eastex regional water supply planning study. vol 2: environmental inventory and issues*. Houston, Texas
- Prose, B.L. 1985. Habitat Suitability Models: Belted Kingfisher. U.S. Department of Interior, Fish and Wildlife Service. FWS/OBS-82/10.87. 22 pp.
- Schroeder, R.L. 1982. Habitat Suitability Models: Downy Woodpecker. U.S. Department of Interior, Fish and Wildlife Service. FWS/OBS-82/10.38. 10 pp.
- Schroeder, R.L. and P.J. Sousa. 1982. Habitat Suitability Models: Eastern Meadowlark. U.S. Department of Interior, Fish and Wildlife Service. FWS/OBS-82/10.29. 9 pp.
- Sousa, P.J. and A.H. Farmer. 1983. Habitat Suitability Models: Wood Duck. U.S. Department of Interior, Fish and Wildlife Service. FWS/OBS-82/10.43. 27 pp.
- Texas Natural Resource Information Service (TNRIS). [Online] (2002). Texas Department of Transportation Road Data. Available URL: <http://www.tnris.state.tx.us/DigitalData/TxDOT/txdot.htm>
- Texas Water Development Board (TWDB). 2002 *Water for Texas*, Austin, Texas.
- U.S. Army Corps of Engineers Environmental Laboratory (USACE). 1987. *Corps of Engineers Wetlands Delineation Manual, Technical Report Y-87-1*, U. S. Army Engineers Waterways Experiment Station, Vicksburg, MS.

- U.S. Department of Agriculture, Natural Resource Conservation Service (NRCS). [Online] (2002). Soil Survey for Smith County. Available URL: http://www.ftw.nrcs.usda.gov/ssurgo_ftp3.html
- U.S. Department of Agriculture, Natural Resource Conservation Service (NRCS). 1959 Soil Survey for Cherokee County, Texas.
- U.S. Fish and Wildlife Service (USFWS). 1980. *Habitat Evaluation Procedure (HEP) Manual (102-104 ESM)*. U.S. Fish and Wildlife Service, Washington, DC.
- U.S. Fish and Wildlife Service (USFWS). 1980. *Habitat Evaluation Procedures (HEP), Ecological Services Manual (ESM) 102*. Division of Ecological Services, U.S. Fish and Wildlife Service, Department of the Interior. Washington, D.C.
- U.S. Soil Conservation Service (1985) *Hydric soils of the United States 1985*. United States Department of Agriculture. Washington, D.C.

TABLE OF CONTENTS

	Page
5.0 MITIGATION FOR POTENTIAL WILDLIFE, WETLANDS, AND CULTURAL RESOURCES IMPACTS	5-1
5.1 Wildlife Habitat	5-1
5.2 Wetlands and Other Waters of the U.S.	5-2
5.3 Cultural Resources	5-6
5.4 Proposed Mitigation.....	5-9
5.4.1 Big Thicket National Preserve Enhancement and Protection.	5-9
5.4.2 Purchase Land Up to Elevation 318 feet NGVD	5-11
5.4.3 Regulate Recreational and Commercial Activities	5-11
5.4.4 Flowage Easement Restrictions	5-12
5.4.5 Waterfowl Management Area	5-12
5.4.6 Cultural Resources	5-12
References:.....	5-15

TABLES	Page
Table 5-1. Net Impacts of Lake Eastex Project for Each Cover Type (AAHUs).....	5-1
Table 5-2. Comparison of Aquatic Functions at the Lake Eastex Site With and Without the Proposed Reservoir	5-4

5.0 MITIGATION FOR POTENTIAL WILDLIFE, WETLANDS, AND CULTURAL RESOURCES IMPACTS

This section summarizes the project impacts identified in the current Planning Studies and describes the mitigation measures that the ANRA proposes to compensate for those impacts. The proposed mitigation measures include components that address wetlands and wildlife habitat impacts, and they also describe ANRA’s proposed approach to mitigating project effects on cultural resources. Information discussed in this section forms the basis for the environmental permitting and mitigation costs included in the opinion of probable construction cost presented in Section 6.0 of this report.

5.1 Wildlife Habitat

As described in previous sections, HEP was the tool used to help quantify project impacts to wildlife habitat. The HEP procedure uses Habitat Units (HUs) as the measure of habitat quality. HUs are calculated by multiplying the cover type area (acres) by the Habitat Suitability Index (HSI) value. Changes in the baseline HUs are then projected into the future for a time period equal to the life of the project (100 years for Lake Eastex). The net impacts of the proposed project are calculated by comparing the difference in Average Annual Habitat Units (AAHUs) between future conditions with and without the project. The net impacts to each cover type are summarized below in Table 5-1.

Table 5-1. Net Impacts of Lake Eastex Project for Each Cover Type (AAHUs)

Cover Type	Area Within Conservation Pool (acres)	Net Impacts (AAHUs)
Deciduous Forested Wetland	3,652	- 2,342
Grassland	2,189	- 960
Upland Forest	2,182	- 1,420
Herbaceous Wetland	1,349	- 315
Riverine	298	- 188
Shrub-scrub Upland	190	- 864
Shrub-scrub Wetland	133	- 702

5.2 Wetlands and Other Waters of the U.S.

As described previously, a total of 5,746 acres of waters of the U.S., including 5,351 acres of wetlands, lie within the conservation pool and the construction area of the dam. Of that total, an estimated 220 acres will be impacted directly by construction and placement of fill for the dam. The remaining 5,526 acres of waters of the U.S. will be modified by inundation.

The national policy with regard to authorized impacts to wetlands, as stated in the USACE Regulatory Guidance Letter No. 02-2 (December 24, 2002), is that there should be “no overall net loss.” This goal was reinforced in the Bush Administration’s *National Wetlands Mitigation Action Plan*, an interagency document issued December 24, 2002, and signed by the Department of the Army, U.S. Environmental Protection Agency, Department of Commerce, Department of the Interior, Department of Agriculture, and the Department of Transportation. The guidance allows the Corps flexibility or discretion in implementing its policy. The intent of both of these documents is to improve the success of compensatory mitigation efforts nationwide and achieve the goal of no net loss.

The USACE’s regulatory guidance letter encourages Corps Districts to use functional assessment instead of the traditional method (based primarily on acres of impacts) of measuring impacts to wetlands and other waters of the U.S. Wetlands generally perform a variety of ecological functions, including some of the more popularly recognized functions such as fish and wildlife habitat and recreation, as well as a number of less commonly recognized traits such as groundwater recharge, nutrient removal and transformation, and flood water retention. The functional assessment of impacted wetlands, as discussed in the regulatory guidance letter, would result in the assignment of values to aquatic functions. These values could be used to identify appropriate mitigation measures that would replace the functions lost due to project impacts, thus resulting in no overall net loss – not on an acreage basis, but on a wetland functions basis.

In 1997, the USACE published *The National Action Plan to Implement the Hydrogeomorphic (HGM) Approach to Assessing Wetland Functions* in the Federal Register (June 20, 1997, Vol. 62, No. 119). The USACE has established a goal of using the Hydrogeomorphic Approach (HGM) to assess the majority of 404 permit applications that

require wetland function assessments. However, the approach requires that HGM functional assessment models be developed for 25-30 regions across the nation. No assessment model has been developed yet for the region encompassing the Lake Eastex project area, nor has any other quantitative technique been established as a locally accepted method to assess wetland functions and develop compensatory mitigation requirements.

Previous sections of this report have described the assessment of wildlife habitat, which is one function of wetlands at the Lake Eastex site. In addition, there are a number of other wetland and aquatic functions that contribute to the ecological character of the site. A preliminary evaluation of impacts was conducted by listing wetland functions published on the USEPA's web site (www.epa.gov/watertrain/wetlands) along with other sources, and identifying whether or not those functions are likely to occur with and without the Lake Eastex project. The results are presented in Table 5-2.

The comparisons shown in Table 5-2 indicate that the Lake Eastex project will continue to have many of the functions that existed prior to construction of the dam and inundation by the reservoir. The functions that will be lost are those that have a significant terrestrial or shallow water dependence, such as hunting, trapping, timber production, and breeding and egg deposition areas for reptiles. Some functions will persist in the reservoir but they may have either a more or less important role than the current setting. For example, the reservoir will retain some ability for aquatic plants to store carbon as plant biomass, but the capacity for carbon sequestering in vegetation will change due to the type of plants associated with the reservoir (primarily plankton and aquatic macrophytes) as compared to the existing wetlands (primarily bottomland hardwood forests, shrub and herbaceous wetlands). On the other hand, the reservoir will serve as a very effective sink for sediment and other water pollutants that easily pass through the existing aquatic ecosystem by stream transport.

One function that will increase most notably and provide a much higher societal value is recreation. Lands throughout the reservoir site are currently in private ownership except for the few county road crossings and public highways. Public recreation is therefore restricted due to lack of access. The reservoir will open up the 10,000 acre site and any surrounding ANRA properties to public use for various types of outdoor recreation (e.g., boating, fishing, swimming, hunting, camping, hiking, bird watching, etc.).

Table 5-2. Comparison of Aquatic Functions at the Lake Eastex Site With and Without the Proposed Reservoir

FUNCTIONS	Functions Present	
	Without Lake Eastex	With Lake Eastex
recreation	yes	yes
hunting	yes	yes
trapping	yes	no
fishing	yes	yes
silviculture	yes	no
aesthetic value	yes	yes
flood water retention	Yes	yes
water-quality improvement	Yes	Yes
aquifer recharge	no	no
terrestrial habitat	yes	no
littoral habitat	no	yes
aquatic habitat	yes	yes
terrestrial biodiversity	yes	no
aquatic biodiversity	yes	yes
Fish, wildlife, and plant habitats*		
source of biodiversity	yes	yes
produce food	yes	yes
organisms that form base of food web	yes	yes
food for birds	yes	yes
food for mammals	yes	yes
water for birds	yes	yes
water for mammals	yes	yes
shelter for birds	yes	yes
shelter for mammals	yes	yes
breeding and egg deposition areas for fish	yes	yes
breeding and egg deposition areas for amphibians	yes	yes
breeding and egg deposition areas for reptiles	yes	no
federally listed T/E species habitat	no	no
Natural water quality improvement and biogeochemical cycling*		
removal of nitrogen from surface water	yes	yes
removal of phosphorus from surface water	yes	yes
improve water/drinking water quality by:	--	--
- intercepting surface runoff	yes	yes
- removing or retaining inorganic nutrients	yes	yes
- processing organic wastes	yes	yes
- reducing suspended sediments	yes	yes
reduce algal blooms (nutrients)	yes	yes
reduce dead zones (nutrients)	yes	yes
reduce fish kills (nutrients)	yes	yes
Atmospheric maintenance*		
moderate global climatic conditions	yes	yes
store carbon as plant biomass	yes	yes

Table 5-2. Comparison of Aquatic Functions at the Lake Eastex Site With and Without the Proposed Reservoir (continued)

FUNCTIONS	Functions Present	
	Without Lake Eastex	With Lake Eastex
Hydrologic cycle roles*		
receive, store, and release water in numerous ways	yes	yes
maintain stream flow during dry periods	yes	yes
replenish groundwater	yes	yes
Flood storage*		
store and slowly release surface water, rain, groundwater, and flood waters	yes	yes
wetland vegetation impedes movement of flood waters and distributes them more evenly over floodplain	yes	yes
counteract increased rate and volume of runoff from pavement and buildings	yes	yes
Shoreline erosion protection*		
protect shorelines and stream banks against erosion	yes	NA
holds the soil in place with their roots	yes	NA
absorbs the energy of waves	yes	NA
breaks up the flow of stream or river currents	yes	NA
Opportunities for recreation, education, research and aesthetic appreciation*		
used to hunt, fish, birdwatch or photograph wildlife	yes	yes
nature-based tourism involves birds, many of which are wetland-dependent	no	no
used for hiking, boating, and other recreational activities	no	yes
used for studies in conjunction with environmental programs	no	no
used for research and teaching sites to learn about vegetation, ecological functions and processes, biodiversity, and plant-animal interactions	no	no
used by artists and writers to capture the beauty of wetlands on canvas and paper, or through cameras, video, and sound recorders	no	no
Economic benefits of natural services and products at little or no cost*		
timber production	yes	no
food crop production	no	no
medicine derived from wetland soils and plants	no	no
commercial fishing and/or shellfishing harvest	no	no
habitats for commercial fur-bearers like muskrat, beaver, otter, and mink, as well as reptiles such as alligators	yes	yes
used for migratory bird hunting	yes	yes
Reduce flood damage and protect our health and safety*		
reduces the likelihood of flood damage to homes, businesses, and crops in agricultural areas	yes	yes
lowers flood heights and reduces erosion downstream and on adjacent lands	yes	yes
reduces or prevents waterlogging of agricultural lands	no	no
causes less monetary flood damage (and related insurance costs), as well as greater protection of human health, safety, and welfare.	yes	yes

*adapted from EPA (www.epa.gov/watertrain/wetlands)

Although the Lake Eastex project will modify or fill a total of 5,746 acres of wetlands and other waters of the U.S., the project will be self-mitigating to some extent. On an acreage basis, the reservoir pool will create a fringe of 2,025 acres of fringe wetland habitat that is 5-feet deep or less when the water surface is at elevation 315 feet NGVD. This acreage will be distributed in a narrow band along the steeper portions of the main lake body, but there will be some large blocks of this habitat in the upper tributary arms and especially at the upper end of the lake along Mud Creek. As discussed above, most of the existing functions will still be present with the reservoir.

5.3 Cultural Resources

Cultural resources include historic and prehistoric archeological sites, historic sites and areas, and architectural remains. The 1991 Lake Eastex Regional Water Supply Planning Study (LAN 1991) provided a detailed discussion of the potential occurrence of historical and archeological resources in the project area. During the present study, the State Historic Preservation Officer (SHPO) was consulted and provided written comments and recommendations (Appendix 6) for ANRA to comply with both state and federal laws and regulations relative to the Lake Eastex project.

Statutory Background

In Texas, cultural resources are protected under two laws: the 1) Texas Natural Resource Code of 1977, Title 9, Heritage, Chapter 191, Antiquities Code of Texas and 2) the National Historic Preservation Act (NHPA) of 1966.

The Texas Antiquities Code declares that it is the public policy and in the interest of the state of Texas to locate archeological sites and other cultural resources in, on, or under any land within the jurisdiction of the State of Texas. It establishes and directs the Texas Antiquities Committee to provide for the discovery and/or scientific investigation of publicly owned cultural resources. The Antiquities Code further directs the Committee, state agencies, political subdivisions of the state (including river authorities), and law enforcement agencies to work together to locate and protect cultural resources when deemed prudent, necessary, and/or in the best interest of the state. To achieve these mandates, the Committee reviews construction plans for projects on public lands (those owned in fee simple or occupied by easement) prior to

development to determine a project's potential impact to cultural resources. Development of the Lake Eastex project by the ANRA, a political subdivision of the State of Texas, is subject to the requirements of the Texas Antiquities Code.

The NHPA, specifically Section 106, requires Federal agencies to consider the effects of their actions on historic properties. The purpose of Section 106 is to protect historic properties from unnecessary harm due to federal actions, including issuance of permits, grants, or loans for a local project. The language of Section 106 of the NHPA, as amended (16 U.S.C. 470f) states the following:

“The head of any federal agency having direct or indirect jurisdiction over a proposed federal or federally assisted undertaking in any State and the head of any federal department or independent agency having authority to license any undertaking shall, prior to the issuance of any license, as the case may be, take into account the effect of the undertaking on any district, site, building, structure, or object that is included in or eligible for inclusion in the National Register. The head of any such federal agency shall afford the Advisory Council on Historic Preservation established under Title II of the Act a reasonable opportunity to comment with regard to such undertaking.”

Section 106 applies to properties already listed in the National Register and to properties not formally determined eligible but that meet specified eligibility criteria. This means that properties that have not yet been listed, and even properties that have not yet been discovered, can be eligible for consideration under Section 106.

The statutory language refers specifically to “undertakings” over which federal agencies have either “direct” or “indirect” jurisdiction. Three kinds of undertakings are alluded to: federal undertakings (actions undertaken directly by a federal agency); federally assisted undertakings (such as activities receiving direct federal financial assistance or such indirect assistance as loan guarantees and mortgage insurance); and federally licensed undertakings (undertakings requiring permits or other entitlements from federal agencies). The requirement for construction of the Lake Eastex dam to be authorized by a U.S. Army Corps of Engineers 404 permit makes the project subject to the requirements of Section 106 of the NHPA.

Recommendations of the SHPO

The SHPO recommended several steps to comply with historic preservation requirements during development of the Lake Eastex project (Appendix 6). Background studies, consisting of a geomorphologic study, archival research, and documentation of artifact collections made by local amateurs, are recommended to characterize the area and lay a foundation for conducting detailed field studies including an archeological survey, testing and data recovery.

The geomorphic study is suggested to provide a specific understanding of how landforms developed in the Mud Creek watershed. This information would allow the geomorphologist to identify the potential locations of buried archeological sites in the project area and, conversely, areas that do not have high potential to contain buried archeological sites. Thus, the results of the geomorphic study would be used to develop a work plan for an archeological survey that would exclude some low-probability landforms from the survey area. For example, areas delineated as wetlands and other waters of the U.S. would not be likely to contain buried archeological sites, so these areas might be excluded from a survey.

Archival research is recommended by the SHPO to help in locating and interpreting early historic sites in the project area. The work must be conducted by a qualified historian/archivist and consists of searching for information on historic settlement and the locations of historic period Indian villages in documents stored at facilities such as the Barker Texas History Center at the University of Texas at Austin, Texas General Land Office, the State Archives in Austin, and in Smith and Cherokee county records.

The SHPO also recommended that a qualified archeologist with experience in Northeast Texas archeology make an effort to interview private citizens who have artifact collections from the project vicinity. A primary goal of this effort would be to familiarize the archeological surveyors with the type of sites and artifacts that might be encountered in the area.

Based on the results of the geomorphic study, and armed with information obtained from archival research and interviews of amateur collectors, the SHPO recommends that an archeological survey of the project area be conducted. The survey should be performed by an

archeologist meeting the professional qualifications listed in the Secretary of Interior's Standards and Guidelines and the Chapter 26 Rules of Practice and Procedure for the Antiquities Code of Texas. Sites that are discovered must be tested for eligibility for listing in the National Register of Historic Places. The SHPO indicates that any sites deemed eligible should be avoided and preserved, if possible. Sites that cannot be avoided must be mitigated by data recovery, which typically includes excavation, documentation, and curation of artifacts in an approved archival facility.

5.4 Proposed Mitigation

Based on the foregoing evaluation of impacts and functional replacement provided by the proposed project, the ANRA proposes to compensate for the remaining impacts to waters of the U.S. and wildlife habitat at the Lake Eastex site by offering the Big Thicket National Preserve (BTNP) Enhancement and Protection Plan (described below) along with other actions to control indirect impacts of the project to adjacent lands. This compensatory mitigation proposal is expected to satisfy the goal of no overall net loss of wetland functions and to provide a significant benefit to public interests by assisting in the preservation of a national and internationally recognized ecosystem in the Neches River basin.

The ANRA recognizes that the proposed compensatory mitigation plan is an unconventional approach to mitigating the effects of a large reservoir project but considers it to be an innovative offer with public benefits that outweigh traditional mitigation strategies. Other components of this mitigation plan would help to avoid or minimize indirect impacts associated with future development activities surrounding the lake.

5.4.1 Big Thicket National Preserve Enhancement and Protection.

The USACE Regulatory Guidance Letter (RGL) No. 02-2 (December 24, 2002) recognizes that "Preservation does not result in a gain of wetland acres and will be used only in exceptional circumstances." The ANRA considers the opportunity to preserve land to add to the BTNP as compensation for adverse impacts due to Lake Eastex an "*exceptional circumstance.*" According to the RGL, Districts can allow preservation alone as mitigation if the District

“...will consider whether the wetlands or other aquatic resources: 1) perform important physical, chemical or biological functions, the protection and maintenance of which is important to the region where those aquatic resources are located; and 2) are under demonstrable threat of loss or substantial degradation from human activities that might not otherwise be avoided.”

Importance

The BTNP, in addition to being designated as a preserve to protect the region’s unique ecological characteristics, is also designated an International Biosphere Reserve by the United Nations Education, Scientific and Cultural Organization (UNESCO) Man and the Biosphere Program and as a Globally Important Bird Area by the American Bird Conservancy.

Threats

The National Parks and Conservation Association on January 14, 2003, designated the Big Thicket National Preserve as one of "America's Ten Most Endangered National Parks" in the National Park Service System (www.npca.org). This designation was based on their assessment of threats facing the Preserve:

“The designation of Big Thicket National Preserve as "endangered" recognizes problems growing out of timber company sales of over 1,000,000 acres in East Texas. Forest industry land that once "protected" Big Thicket's small remote units and narrow corridors now are subject to urban sprawl and adverse development as well as compounding the problems of fragmentation”

“More than 1.5 million acres of timber-company land surrounding the preserve have been made available for sale since 2001. The Park Service and conservationists support an expansion of the preserve that includes less than 10 percent of the timber lands for sale. Nevertheless, at least one timber company has balked at selling a small portion of its holdings to expand the preserve. If the land is sold for non-preservation uses, clear cutting and development could damage lands up to the edges of biologically sensitive Big Thicket.”

“A project in progress to widen a 100-mile stretch of U.S. 69 that passes through the preserve would further encourage sprawling development, bringing air, water, and light pollution and fracturing migratory corridors not protected within the preserve.”

According to the Big Thicket Association (www.bta.org):

“Unless we act quickly to acquire and add some of these lands the BTNP will be surrounded by a sea of development. Protection of the Big Thicket National Preserve has entered a crucial land acquisition phase, which may determine if the National Park System Unit survives the 21st century.”

Plan Components

The main focus of the ANRA Lake Eastex mitigation plan is to place \$5,000,000 into an escrow account to be used to purchase environmentally important lands which would be added to the Big Thicket National Preserve. These funds would be added to federal funds authorized in the Congressional budget process.

Purchases from the escrow fund would be made by two organizations widely respected and recognized both nationally and internationally as leaders in the protection and conservation of environmentally important areas around the world. They will be formally aligned with ANRA to carry out these purchases for the Big Thicket area.

These purchases will be consistent with the Management Plan for the Big Thicket National Preserve which is a division of the Department of Interior. They are also consistent with the goals of the Big Thicket Association, a grass roots volunteer organization, dedicated to the preservation and enhancement of the Big Thicket.

5.4.2 Purchase Land Up to Elevation 318 feet NGVD

ANRA would purchase land around Lake Eastex up to elevation 318 feet NGVD and prohibit unpermitted development within this area. This proposal would avoid indirect impacts to approximately 1,029 acres of land contiguous with the conservation pool.

5.4.3 Regulate Recreational and Commercial Activities

ANRA would obtain authority or cooperate with resource agencies to regulate boating, fishing, hunting and other recreational and commercial activities on and surrounding Lake Eastex. As Lake Manager ANRA would enact and enforce regulations to minimize adverse impacts to water quality by erosion control, septic tank restrictions, fuel spill containment, etc.

5.4.4 Flowage Easement Restrictions

ANRA will obtain flowage easements which will regulate development around the reservoir. Flowage easements would be purchased for land from 318 ft NGVD up to elevation 326 ft NGVD. Approximately 3,350 acres would be included. Development restrictions would minimize the secondary impacts of development in the vicinity of the reservoir and avoid flood damage to habitable structures.

5.4.5 Waterfowl Management Area

ANRA would set aside and manage (in cooperation with appropriate resource agencies or private conservation organizations) the reservoir area upstream of State Highway 135 for waterfowl management. The water depth within the proposed conservation pool for this area would be five feet or less and should provide approximately 500 acres of good habitat for waterfowl and other wildlife. Timber in this area would not be cleared for reservoir construction, but would be left standing to provide cover and some wildlife food (acorns, etc.) production. Features of this option could include 1) creating a buffer zone around the area to minimize impacts of future development, 2) providing access points for boats and walk-ins, and 3) habitat enhancements such as nest boxes and food plots. Creation of this waterfowl management area would avoid and minimize some of the project impacts on wetland functions such as waterfowl habitat; sport hunting; wildlife observation; canoeing and other recreational boating; and breeding and egg deposition areas for fish, amphibians, and reptiles. Depending on the extent and duration of inundation, portions of shallow water areas could remain in standing timber or be converted to emergent and shrub-scrub wetlands. In certain areas downstream of State Highway 35 and upstream of US Highway 79, only boat lanes would be cleared, leaving peripheral trees standing.

5.4.6 Cultural Resources

It is assumed that ANRA will have to include in an archeological survey 1) the lands purchased in fee simple, plus 2) the additional flowage easement purchase area. This amounts to a total area of approximately 14,500 acres. However, it is also assumed that 90 percent of the area delineated as waters of the U.S., or 5,370 acres, will be excluded from the archeological survey requirement, as these areas should have low probability to contain buried sites. Thus, it

is assumed that the survey area will include approximately 9,130 acres. The estimated cost to cover the cultural resources activities such as the geomorphic study, archeological survey, testing and data recovery, and curation of artifacts is \$7,269,900.

The ANRA anticipates soliciting technical and fee proposals from cultural resources investigators with known experience in completing studies of the size and nature of the Lake Eastex project. This will be done upon identification of the requirements for cultural resources investigations and after it appears that a 404 permit will be issued. The SHPO's recommendations (Appendix 6) indicate the need to employ "qualified" specialists for these studies, including geomorphologists, historian/archivists, and archeologists. Thus, ANRA's selection of a contractor(s) to perform the studies will be based on technical approach, professional qualifications of the principal investigator, and the budgeted funds to conduct the work.

References:

Lockwood, Andrews and Newnam, Inc. (LAN). 1991. *Lake Eastex Regional Water Supply Planning Study*. Houston, Texas

TABLE OF CONTENTS

6.0 EVALUATION OF ENGINEERING DESIGN..... 6-1

- 6.1 Site Description..... 6-1
- 6.2 Hydrologic Modeling..... 6-1
 - 6.2.1 Watershed Characteristics..... 6-1
 - 6.2.2 Hydrograph Development..... 6-3
- 6.3 Preliminary Design 6-7
 - 6.3.1 TCEQ Regulations..... 6-7
- 6.4 Geotechnical Analysis 6-10
 - 6.4.1 Geology..... 6-10
 - 6.4.2 Dam Foundation..... 6-11
 - 6.4.3 Embankment Design..... 6-12
- 6.5 Conflict Identification..... 6-13
 - 6.5.1 Communication Utilities..... 6-14
 - 6.5.2 Electric Utilities 6-14
 - 6.5.3 Oil and Gas Utilities..... 6-14
 - 6.5.4 Water Lines..... 6-14
 - 6.5.5 Transportation 6-15
- 6.6 Land Acquisition..... 6-15
- 6.7 Opinion of Probable Construction Cost..... 6-15
- References..... 6-17

FIGURES	Page
Figure 6-1. Location Map	after page 6-1
Figure 6-2. Land Use in the Lake Eastex Watershed.....	6-2
Figure 6-3. Drainage Area Map	after page 6-2
Figure 6-4. Calculated and Measured Hydrographs for the Lake Eastex HEC-1 Model.....	6-5
Figure 6-5. Probable Maximum Precipitation.....	after page 6-6
Figure 6-6. Probable Maximum Flood 72-Hour Rainfall	6-6
Figure 6-7. Service Spillway.....	after page 6-8
Figure 6-8. Emergency Spillway Plan and Profile.....	after page 6-8
Figure 6-9. Spillway Rating Curve	6-8
Figure 6-10. Typical Embankment Section	after page 6-9
Figure 6-11. Outlet Works Plan and Profile	after page 6-9

TABLES	Page
Table 6-1. Drainage Areas	6-2
Table 6-2. Sub-basin Hydrologic Parameters	6-4
Table 6-3. Rainfall Data	6-6
Table 6-4. Peak Inflows, Discharge and Reservoir Stage Data	6-7
Table 6-5. Spillway Rating Curve Data.....	6-9
Table 6-6. Lake Eastex Dam.....	6-10
Table 6-7. Conflicts	6-13
Table 6-8. Opinion of Probable Construction Cost for the Lake Eastex Project	6-16

6.0 EVALUATION OF ENGINEERING DESIGN

This section of the report describes the methodology used to develop the preliminary design of the dam and spillways. The hydrology for the watershed was updated and a preliminary geotechnical investigation was conducted. Preliminary cost estimates for the project are also included.

6.1 Site Description

The Lake Eastex dam site is located on Mud Creek, approximately three miles downstream from U.S. Highway 79 in Cherokee County, Texas. The dam site is located approximately five miles southeast of Jacksonville, Texas as shown in Figure 6-1. The upper reaches of the reservoir will extend into Smith County. Mud Creek is a tributary of the Angelina River which is a tributary of the Neches River. The Mud Creek area at the dam site is a broad alluvial floodplain with a streambed elevation of 265 feet NGVD. The floodplain is broad and flat, approximately 6,000 feet wide, with a ground elevation of 270 feet NGVD. The abutments are steep slopes with elevations of 330 feet NGVD on the west side and 350 feet NGVD on the east abutment. The area is located in the Piney Woods region of Texas and is characterized by pine trees and hardwood timbers located in the river valleys. The topography is generally rolling to hilly with broad, flat floodplains. The proposed lake would have a conservation pool elevation of 315 feet NGVD, which, when full, will produce a surface area of approximately 10,000 acres and a storage volume of 195,500 acre-feet. The normal pool elevation and storage were based on a previous yield study of the reservoir site by LAN (1984). Area and capacity of the reservoir were determined by digitizing the contours on USGS quadrangle maps of the reservoir site. Area and capacity data are provided in Appendix 2.

6.2 Hydrologic Modeling

6.2.1 Watershed Characteristics

The drainage area for Lake Eastex is 384 square miles, of which the existing Tyler lakes control 107 square miles in the upper portion of the watershed. This includes approximately 46 square miles upstream from Whitehouse Dam and 68 square miles upstream from Mud Creek

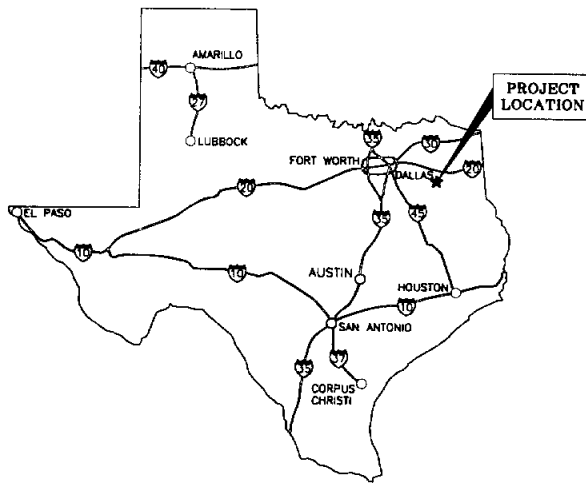

LOCATION MAP

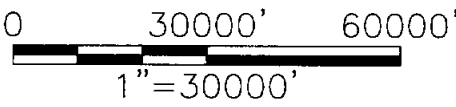
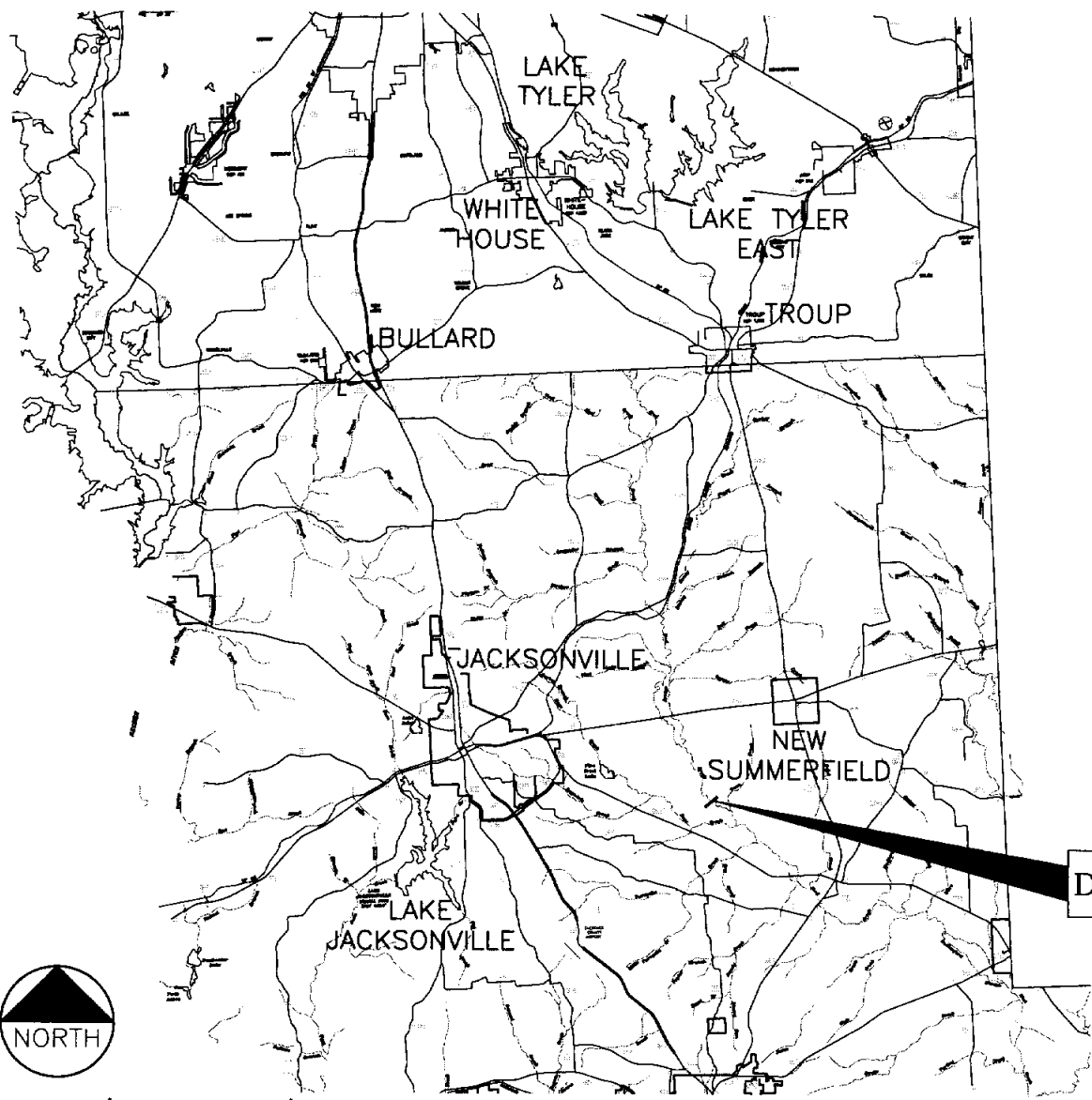

VICINITY MAP

ANR01289 I:\WR\CV-ALL-PL-LMAP.DWG LAYOUT: Layout1
 Mar 20, 2003 - 11:01 am LIS: 1 PSLTS: 1 TWIST: 0.0
 REFERENCES: N:\BASE\CHEROKEE.DWG, N:\BASE\SMITH.DWG, N:\Standard\BPORDER.DWG



ANGELINA AND NECHES RIVER AUTHORITY
 LAKE EASTEX

LOCATION MAP &
 VICINITY MAP

F&N JOB NO.	ANR01289
DATE	NOV. 2002
SCALE	AS SHOWN
DESIGNED	JCM
DRAFTED	MDC
FILE	CV-ALL-PL-LMAP.DWG

6-1
 FIGURE

Dam. The watershed is mostly rural in nature but includes portions of the City of Tyler, along with the cities of Bullard, Troup, and New Summerfield. Land use in the area is mostly agricultural and forest lands. A chart showing a breakdown of the land use in the area is shown in Figure 6-2. For the hydrological analyses, the 384 square mile drainage area was subdivided into 6 subbasins as shown in Figure 6-3. These drainage areas are summarized in Table 6-1.

Figure 6-2. Land Use in the Lake Eastex Watershed

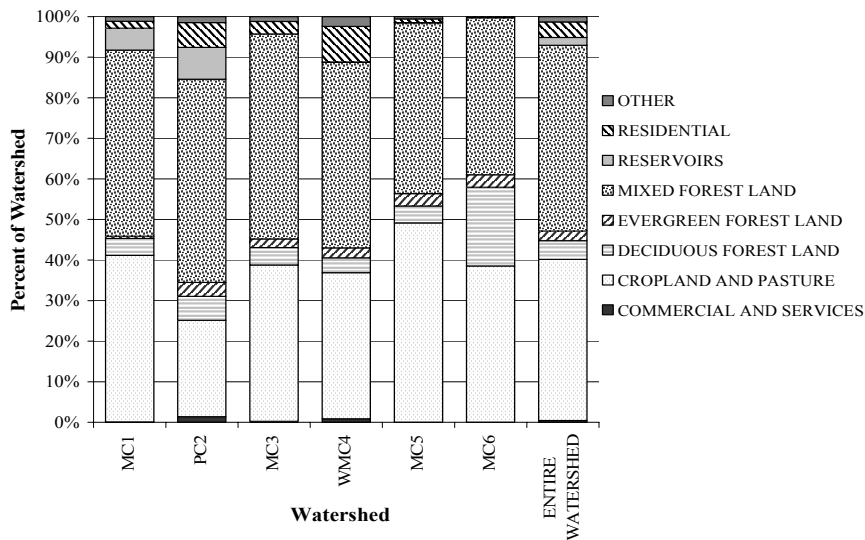
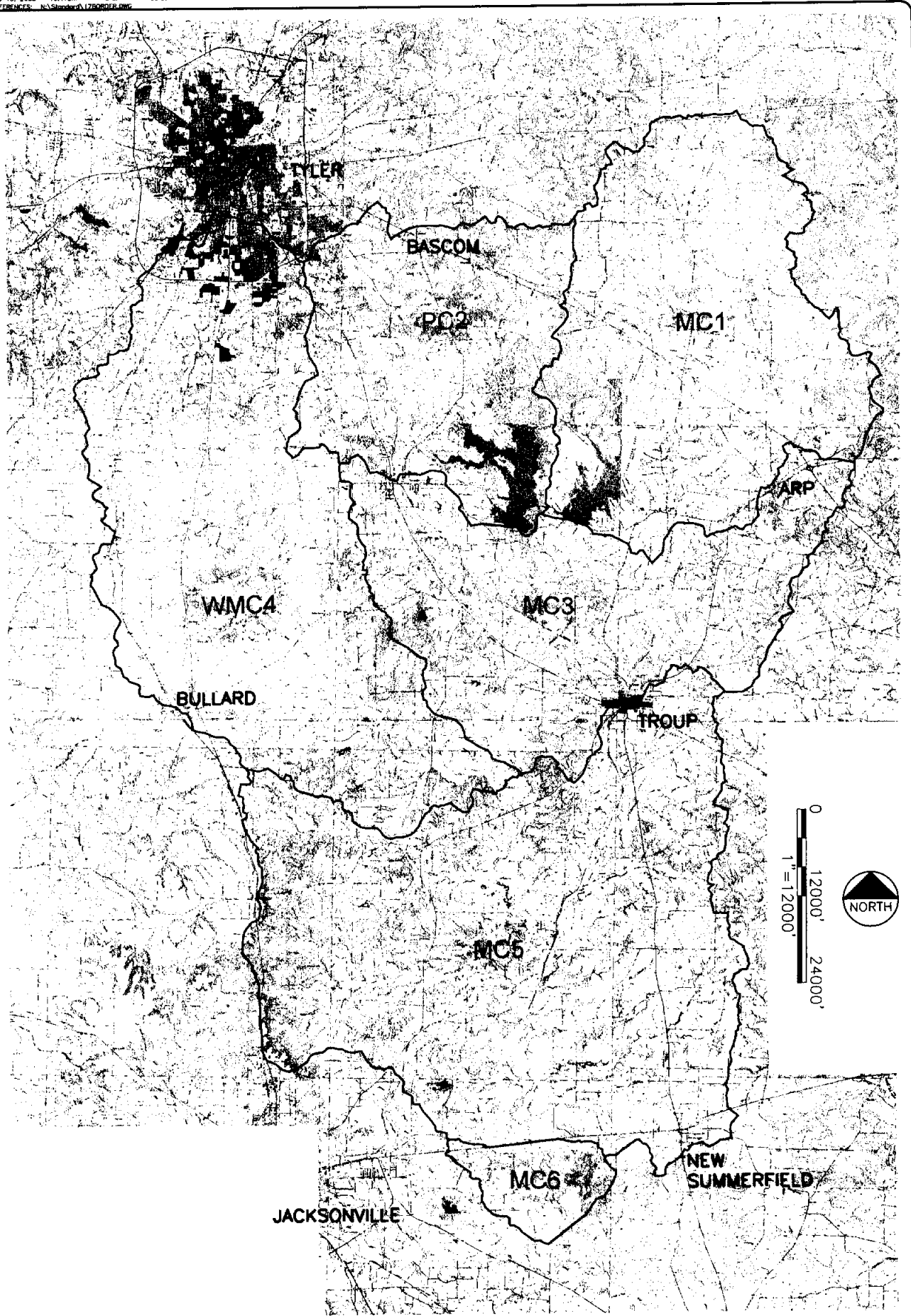

Table 6-1. Drainage Areas

Description	Basin Number	Drainage Areas (sq. mi.)
Lake Tyler	PC2	45.7
Lake Tyler East	MC1	67.9
Kickapoo Creek and Mud Creek downstream of Lake Tyler	MC3	58.5
West Mud Creek	WMC4	91.6
Mud Creek downstream of West Mud Creek	MC5	112.8
Mud Creek downstream of U.S. Hwy. 79	MC6	7.5

The drainage areas were determined from U.S. Geological Survey quadrangle maps (scale 1:24,000), delineated digitally in a GIS environment. Basins No. PC2 and MC1 are controlled by the Tyler Lakes. Lake Tyler (Whitehouse Dam) was constructed in 1949 (TWDB



6-3
FIGURE



ANGELINA AND NECHES RIVER AUTHORITY
LAKE EASTEX

DRAINAGE AREA MAP

P&E JOB NO. ANR01269
DATE NOV 2002
SCALE AS SHOWN
DESIGNED JCM
DRAFTED MDC

PL
CV-DBA-PL-MAPS.DWG

1971). Lake Tyler East (Mud Creek Dam) was constructed in 1967 (TWDB 1971). In 1968 the two lakes were combined with the construction of an equalizing channel. The combined spillway discharge-rating curve for Lake Tyler and Lake Tyler East was developed, and the combined storage of the two reservoirs was included in the routing model. However, the outflow for each separate spillway was routed through its respective channel downstream to the point of confluence and combined with the estimated outflow from the subsequent subbasin for flood hydrograph development.

6.2.2 Hydrograph Development

The Corps of Engineers HEC-1 Flood Hydrograph Program (USACE 1985) was used to develop flood hydrographs for each subbasin for each of the flood events considered. Hydrographs are graphical representations of stream flow with respect to time at particular points of interest. Snyder's Unit Hydrograph was chosen as the most appropriate method within HEC-1 for developing flood hydrographs, as it is typically used for drainage areas over about 200 acres. Hydrologic properties required for the procedure include basin length, length to the centroid of the basin, and the basin slope. From these measured values, combined with the dimensionless parameter of C_t , the lag time of a unit hydrograph was developed for each subbasin. This method is detailed in the U.S. Army Corps of Engineers Engineering Manual (EM1110-2-1405) Flood Hydrograph and Analysis and Computations. Snyder's empirical formula for computing watershed lag time is:

$$L = C_t(l \times l_{ca} / S^{0.5})^{0.33}$$

Where:

L = watershed lag time, in hours

l = hydraulic length of the watershed in feet

l_{ca} = length along main channel to a point nearest the watershed centroid

C_t = coefficient derived from gauged watershed in the same region

S = slope of the watershed in feet per mile

The coefficient C_t can be determined by calibration, or a regional value can be used where calibration is not possible. Typical values for this area range from about 2 to 6. A value for C_t of 5.7 was calibrated for the Lake Eastex watershed, as described in the next section. Additional input data required for the calculation of flood hydrographs include the dimensionless shape factor, $640C_p$, for which a calibrated value of 512 was developed, and

rainfall infiltration rates. Table 6-2 below shows the measured parameters for each subbasin and the estimated lag time.

Table 6-2. Subbasin Hydrologic Parameters

Basin	<i>l</i> (mi)	<i>l_{ca}</i> (mi)	Slope (ft/mi)	Lag Time (hr)
MC1	14.7	8.0	6.12	20.42
PC2	11.2	5.8	14.9	14.51
MC3	17.3	8.1	9.1	20.28
WMC4	27.2	15.0	6.8	30.15
MC5	21.5	13.8	7.3	26.84
MC6	5.8	2.2	17.5	8.22

Calibration

The historical storm of record occurred from April 24 to April 29, 1966. This storm produced 7.6 inches of rainfall in 48 hours on average over the entire watershed. The storm caused record discharges at the USGS stream gage on Mud Creek at Highway 79. The peak discharge of 27,500 cfs occurred on April 25, 1966, with a gage height of 15.2 feet. Using the measured characteristics for each subbasin, the measured rainfall and discharge information available from the 1966 storm, appropriate values for C_t , and $640 C_p$ were developed by matching the discharge calculated by the HEC-1 model and the measured discharges at the gauge. The calculated and measured hydrographs are shown in Figure 6-4.

Final calibrated values for C_t , and $640 C_p$ were estimated to be 5.7 and 512, respectively. The new lag times for each subbasin, based on these values, were input back into the HEC-1 model in order to develop estimates for the various frequency floods and the Probable Maximum Flood (PMF). Infiltration loss rates were also estimated for the calibration, but were not used in the final analysis since soil conditions and possible errors in rainfall measurements generally skew calibrated loss rates. Regional loss rates of 1.0 inch initial loss and 0.05 inches per hour were utilized in the final analysis.

Figure 6-4. Calculated and Measured Hydrographs for the Lake Eastex HEC-1 Model

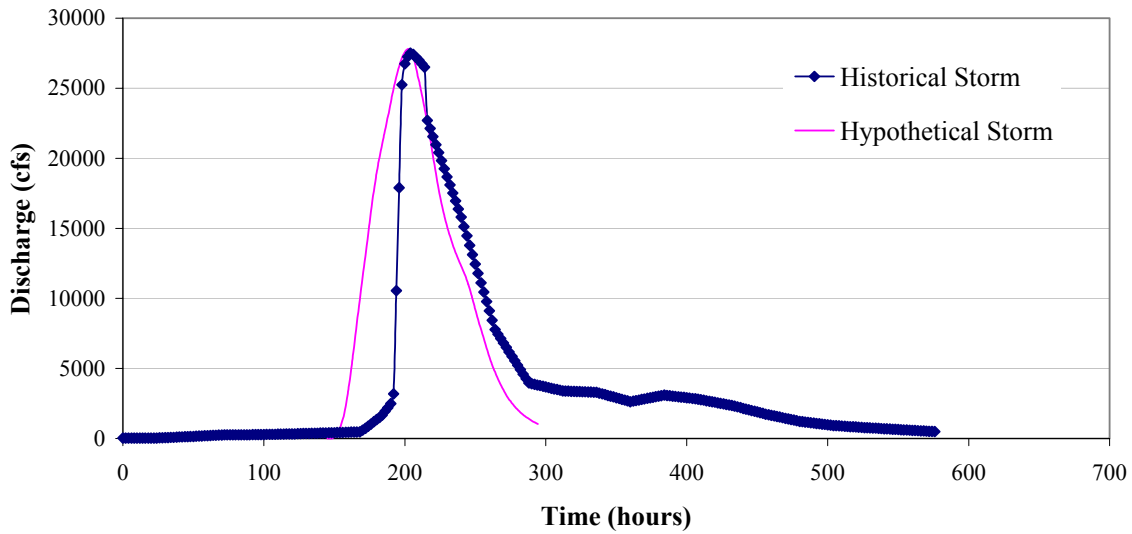

Rainfall

Rainfall data, adjusted for the overall basin size, for the various frequency floods were obtained from Hydro-35 (NWS 1977) for the 5-, 15-, and 60-minute durations and from TP-40 (NWS 1972) for the 2-, 3-, 6-, 12-, and 24-hour durations. Data were generated for the 2-, 5-, 10-, 25-, 50- and 100-year storm events. These values were utilized for all of the subbasins in the routing procedures Rainfall amounts are shown in Table 6-3.

The Probable Maximum Precipitation (PMP) was developed using Hydro-Meteorological Report Nos. 51 and 52 (NWS 1978, 1982, respectively). Rainfall depths for various durations and storm area sizes were taken from these reports and input into HMR52, a computer model developed by the U.S. Army Corps of Engineers that distributes the precipitation over the watershed and calculates the basin average PMP rainfall during each 15-minute time step for each of the sub-basins in the watershed. The storm center was varied in HMR52, producing incremental rainfall amounts for input into HEC-1. Initially the storm was centered at the centroid of the entire drainage area. Additional runs were made with storms centers moving away from the centroid in 0.1 mile increments to verify the critical storm location and configuration that produced the maximum rainfall amount. The critical storm center, which resulted in the maximum rainfall, was located approximately 2 miles east and 0.2 miles south of

Probable Maximum Flood (PMF)
 The PMF is the flood resulting from the highest rainfall intensity meteorologically possible for a given duration over a specific area.

the centroid of the watershed, with a storm area of 450 square miles and an orientation of 264 degrees. The orientation and intensity of the Probable Maximum Flood (PMF) rainfall is shown in Figure 6-5. The final average rainfall for each subbasin is shown in Figure 6-6.

Table 6-3. Rainfall Data

Duration	2-year	5-year	10-year	25-year	50-year	100-year
5 minutes	0.52	0.60	0.65	0.74	0.81	0.88
15 minutes	1.12	1.28	1.41	1.60	1.75	1.90
60 minutes	2.02	2.47	2.80	3.27	3.63	4.00
2 hours	2.52	3.27	3.25	3.65	4.88	5.41
3 hours	2.77	3.55	3.57	4.06	5.42	6.00
6 hours	3.28	4.31	4.3	5.00	6.77	7.57
12 hours	3.88	5.13	05.23	5.98	8.02	9.04
24 hours	4.48	5.99	6.13	6.98	9.44	10.51

Figure 6-6. Probable Maximum Flood 72-Hour Rainfall

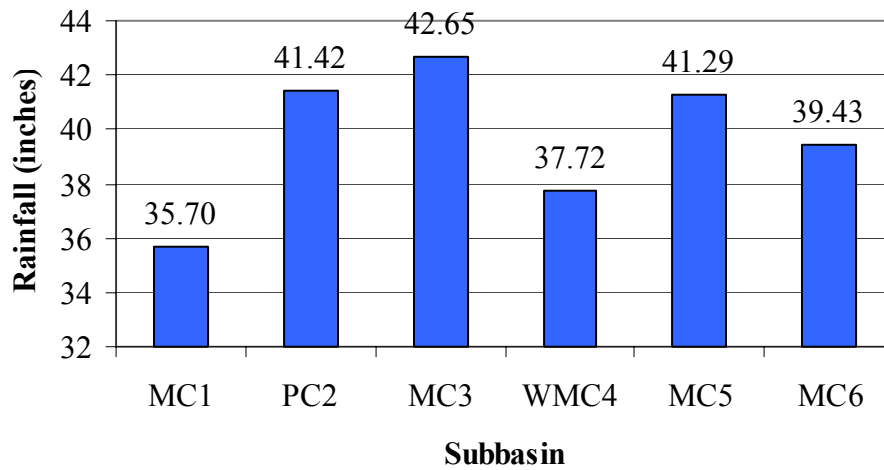

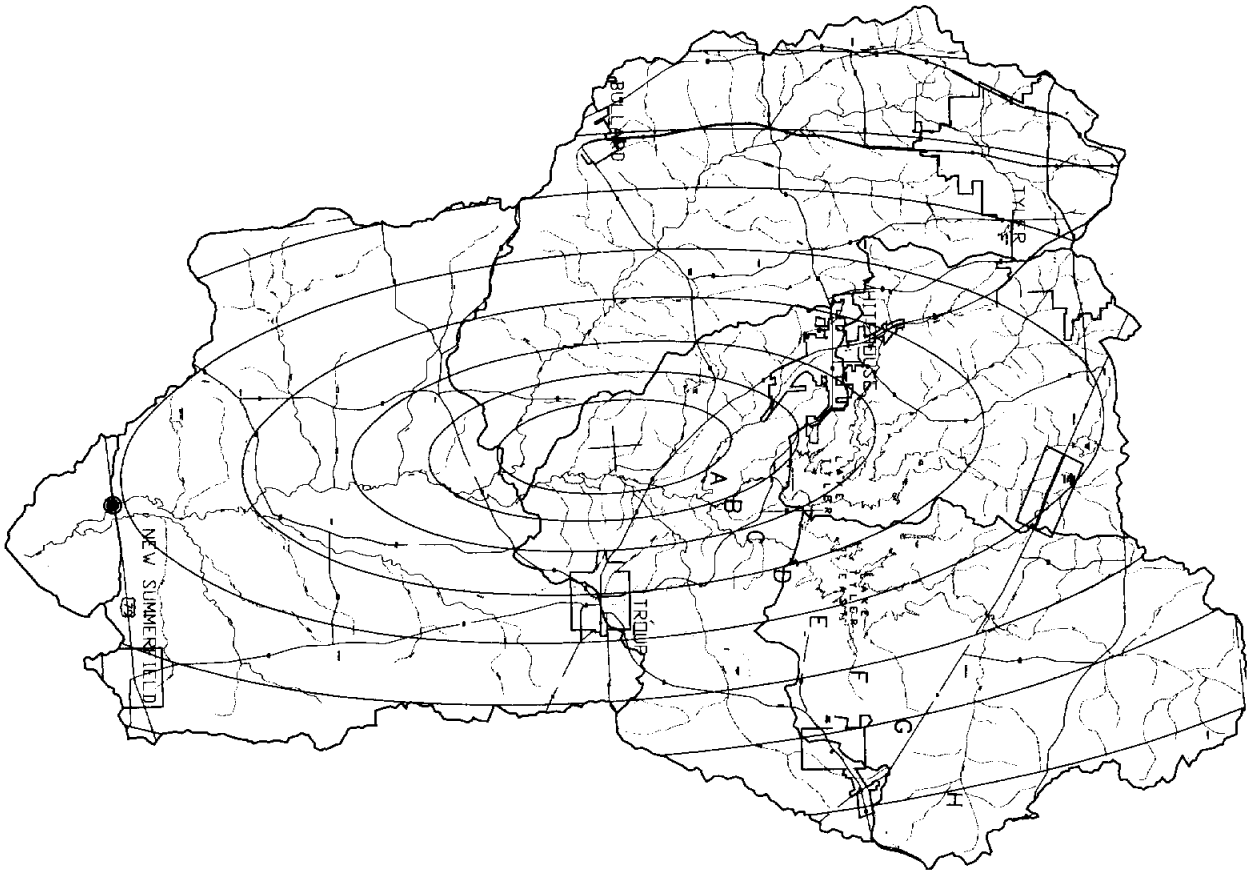

ISOHYET	AREA (SQ. MILES)	72-HOUR RAINFALL (INCHES)
A	10	47.74
B	25	45.85
C	50	43.96
D	100	42.14
E	175	40.57
F	300	38.80
G	450	37.27
H	700	29.33
I	1000	24.17
J	1500	19.50
K	2150	15.86
L	3000	12.47
M	4500	8.84
N	6500	5.17
O	10000	1.87

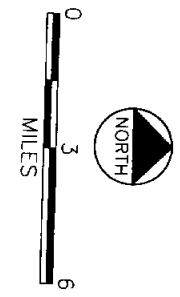

● MUD CREEK NEAR JACKSONVILLE
USGS STREAM FLOW GAGING STATION

ANGELINA AND NECHES RIVER AUTHORITY
 LAKE EASTEX
 PROBABLE MAXIMUM PRECIPITATION

FILE	FIGURE1 - PMP.dwg
T&N JOB NO.	NRD1288
DATE	NOV. 2002
SCALE	AS SHOWN
DESIGNED	JA
DRAFTED	JA

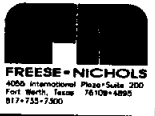

Reservoir Inflows

Peak inflows into the reservoir were calculated for the various frequency floods and the PMF event. The peak stage and discharge are based on a normal pool elevation of 315 feet NGVD, a 200-foot wide service spillway and a 1,100 –foot wide emergency spillway. Inflow, discharge, and stage for each of the frequency floods and the PMF event are presented in Table 6-4.

Table 6-4. Peak Inflows, Discharge and Reservoir Stage

Frequency	Peak Inflow (cfs)	Peak Discharge (cfs)	Peak Stage (feet NGVD)
2-year	13,034	3,478	317.79
5-year	20,829	6,639	319.31
10-year	21,602	6,994	319.46
25-year	26,462	9,069	320.31
50-year	41,199	15,004	322.43
100-year	47,278	17,687	323.3
PMF	214,019	148,552	335.21

6.3 Preliminary Design

6.3.1 TCEQ Regulations

In Texas, the Texas Commission on Environmental Quality (TCEQ) is the regulatory agency responsible for administration of the State’s dam safety laws. Dams are classified according to size and the potential for loss of human life and/or property damage within the area downstream of the dam. The size classification of small, intermediate, or large is based on the storage in the reservoir and height of the embankment. Large dams are those with greater than 50,000 acre-feet of storage or a height of equal to or greater than 100 feet. Although Lake Eastex is only about 65 feet in height, it has a storage capacity of 195,500 acre-feet, placing it in the “large” category. Based on its size classification, the Lake Eastex dam is required to pass 100 percent of the PMF event through the spillways without overtopping the dam.

Spillway Design

The service and emergency spillway will both be uncontrolled structures, meaning that no gates or operated equipment will be used. The crest of the service spillway was set at the

normal pool elevation of 315 feet NGVD. The emergency spillway crest was set so as to not be engaged until a storm event in excess of the 100-year event occurs. Preliminary sizing of the service and emergency spillways was done using the HEC-1 (USACE 1985) flows for the PMF and 100-year storms. Using an iterative process, the spillways were sized such that the crest of the emergency spillway was set above the 100-year storm event and the top of dam set above the PMF, as required by TCEQ. Conceptual plans for the service and emergency spillways are shown in Figures 6-7 and 6-8, respectively.

Rating curves for the service spillway configurations considered were each developed assuming an ogee crest shape and hydraulic design criteria from the Bureau of Reclamation's *Design of Small Dams* (BuRec 1987). The rating curves for the emergency spillway configurations assumed a flat open crest cut into the right or west abutment. These rating curves were combined and input into the HEC-1 for each configuration analyzed. The rating curve is shown in Figure 6-9 and Table 6-5.

Figure 6-9. Spillway Rating Curves

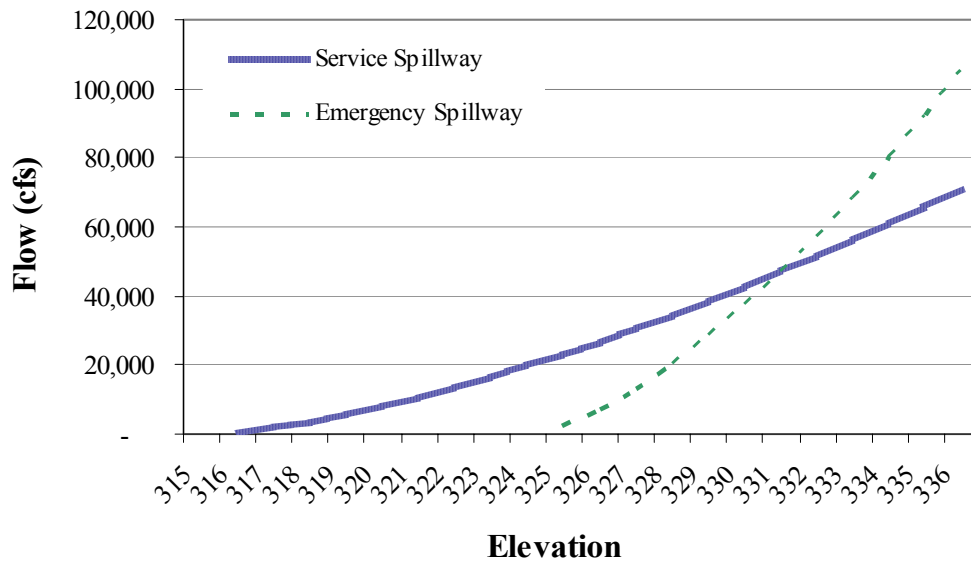

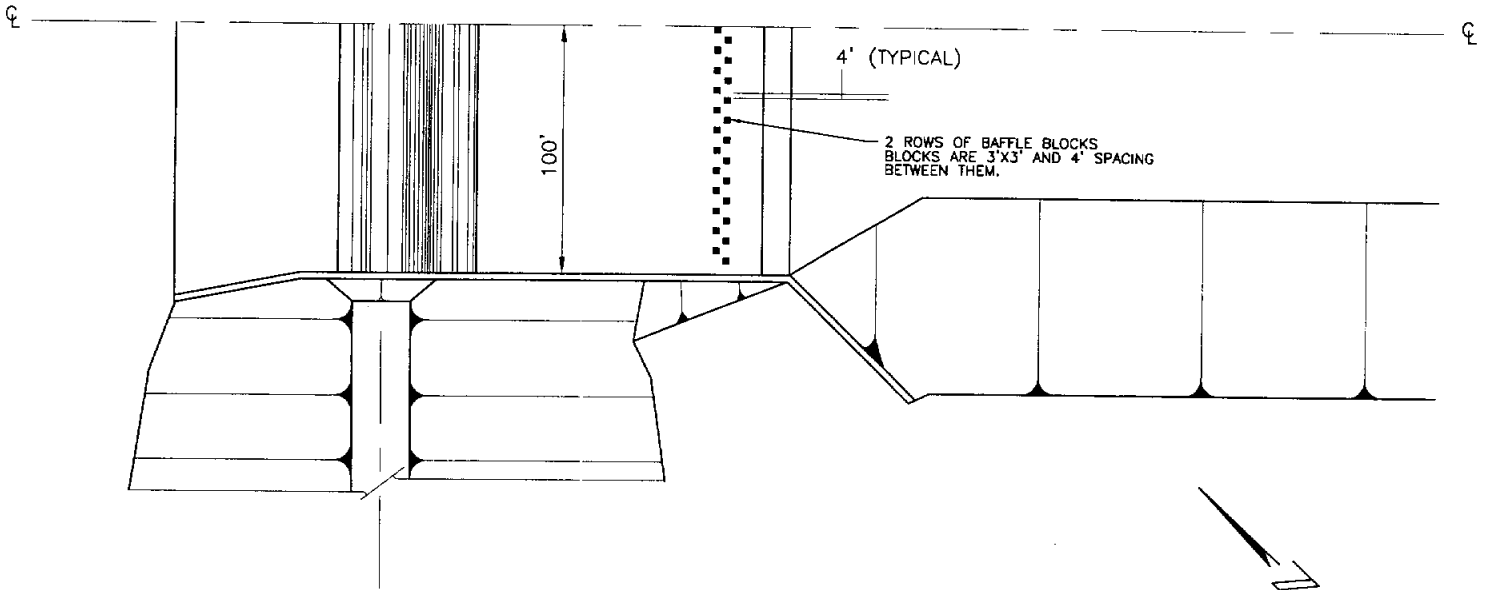

SERVICE SPILLWAY HALF-PLAN

75 0
SCALE: 1"=75'

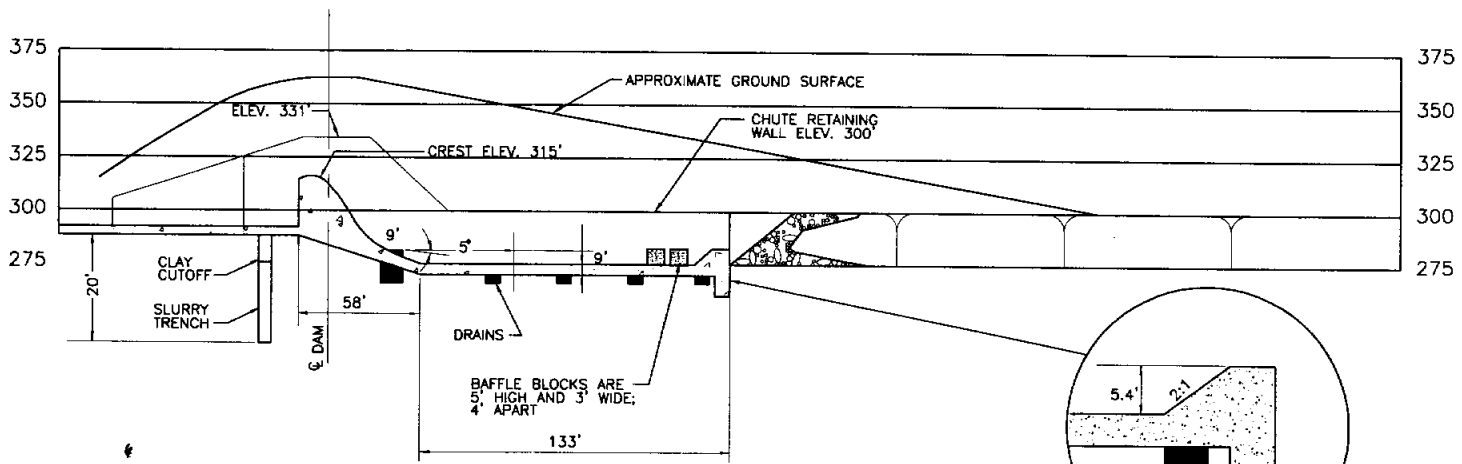

SERVICE SPILLWAY CENTERLINE SECTION

20 0
SCALE: 1"=20'

SILL BLOW-UP DETAIL

ANR01289 N:\WR\CV-SSP-PS-PLAN.DWG LAYOUT: Layout1
 Nov 20, 2003 11:35am LTS: LJS
 REFERENCES: N:\STANDARD\BORDER.DWG



ANGELINA AND NECHES RIVER AUTHORITY
LAKE EASTEX

SERVICE SPILLWAY

F&N JOB NO.	ANR01289
DATE	NOV. 2002
SCALE	AS SHOWN
DESIGNED	JCM
DRAFTED	MDC
FILE	CV-SSP-PS-PLAN.DWG

6-7

FIGURE

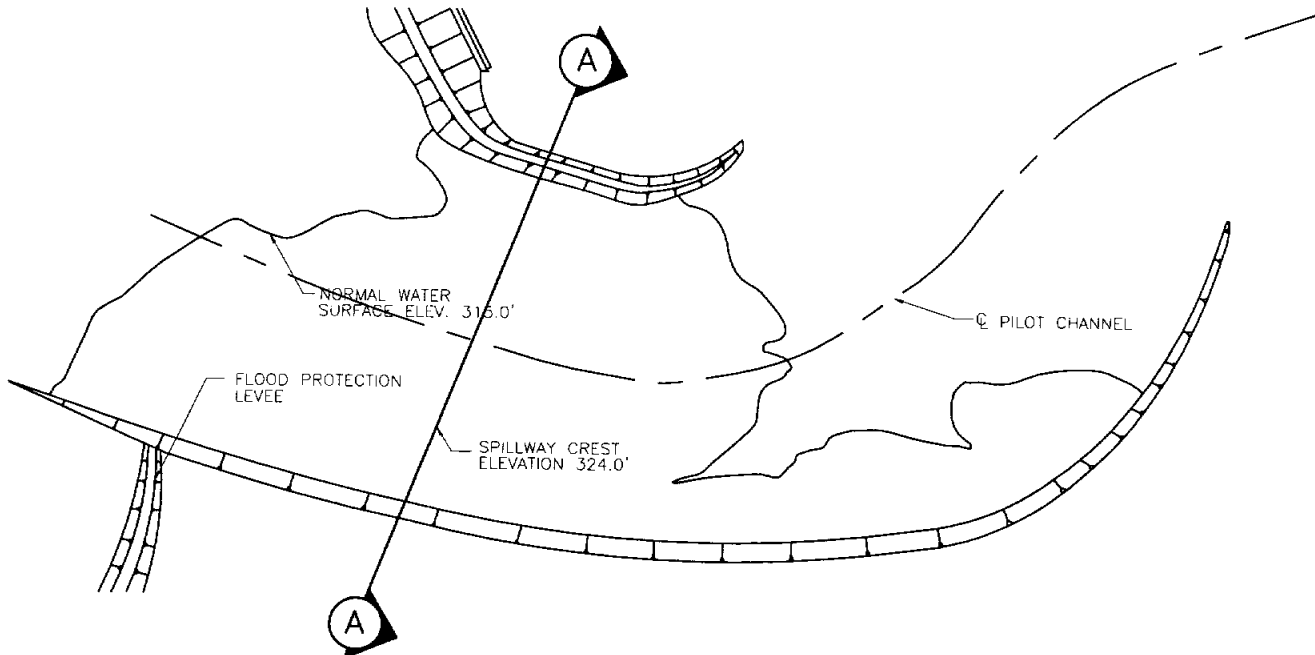

EMERGENCY SPILLWAY PLAN

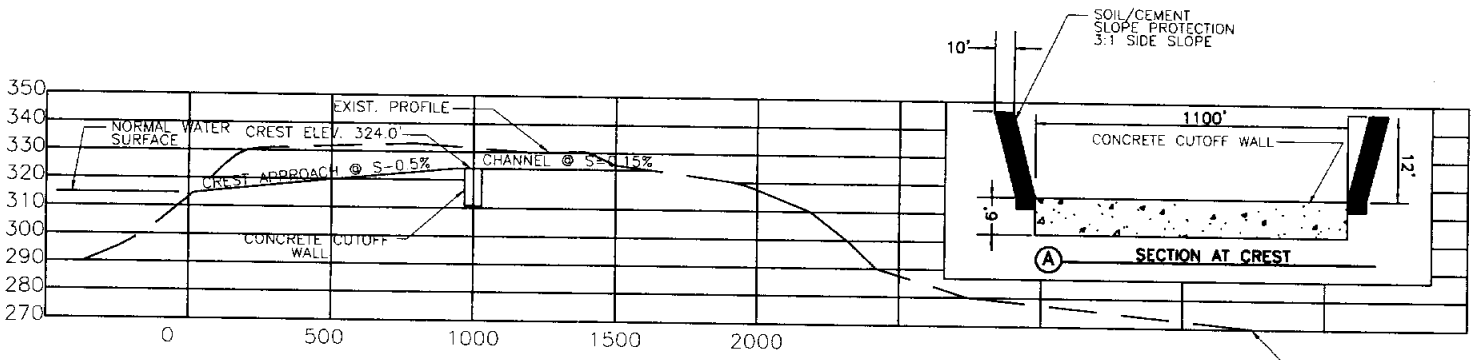

EMERGENCY SPILLWAY PLAN

500 0
SCALE: 3/4"=500'

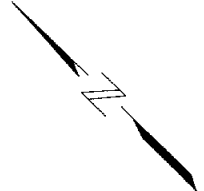

ANR01289 N:\WR\CV-ESP-PP-PLAN.DWG LAYOUT: Layout1
 Mar 20, 2003 11:43am LTS: 1
 REFERENCES: N:\STANDARD\BORDER.DWG TWST: 0.0



ANGELINA AND NECHES RIVER AUTHORITY
 LAKE EASTEX

EMERGENCY SPILLWAY
 PLAN AND PROFILE

F&N JOB NO	ANR01289
DATE	NOV. 2002
SCALE	AS SHOWN
DESIGNED	JCM
DRAFTED	MDC
FILE	CV-ESP-PP-PLAN.DWG

6-8

FIGURE

Table 6-5. Spillway Rating Curve Data

Elevation (NGVD)	Service Spillway (cfs)	Emergency Spillway (cfs)	Combined Outflow (cfs)	Elevation (NGVD)	Service Spillway (cfs)	Emergency Spillway (cfs)	Combined Outflow (cfs)
315	0	0	0	326	26,997	7,156	34,153
316	740	0	740	327	30,761	13,146	43,907
317	2,093	0	2,093	328	34,685	20,240	54,925
318	3,845	0	3,845	329	38,764	28,286	67,050
319	5,920	0	5,920	330	42,990	37,183	80,173
320	8,273	0	8,273	331	47,360	46,856	94,216
321	10,876	0	10,876	332	51,869	57,247	109,116
322	13,705	0	13,705	333	56,512	68,310	124,822
323	16,744	0	16,744	334	61,286	80,006	141,292
324	19,980	0	19,980	335	66,188	92,302	158,489
325	23,401	2,530	25,931	336	71,213	105,170	176,383

In addition, from the available mapping, cross sections were developed along the proposed spillways and dam in order to estimate required excavation and fill volumes during construction. The service and emergency spillway widths and elevations were finalized by trying to balance the required excavation with the fill volumes to make full use of the material excavated from the spillways in the random fill sections of the dam. This helps to minimize the total cost of the structure. The final combination was a 200-foot wide service spillway with a crest elevation of 315.0 feet NGVD and a 1,100-foot wide emergency spillway at elevation 324.0 feet NGVD. For this configuration, the peak 100-year flood elevation was 323.29 feet NGVD and the peak PMF level was 335.21 feet NGVD. Based on this, a top of dam of 336 feet NGVD was assumed. A typical embankment section is shown in Figure 6-10.

The outlet works for the dam would consist of two 48-inch diameter conduits through the dam. A stilling basin would be on the downstream end. The inlet structure in the lake would consist of a tower structure with three gates at different elevations for low flow releases. Pertinent data on the dam are summarized in Table 6-6. A conceptual plan for the outlet works is shown in Figure 6-11.

ZONE	DESCRIPTION	USC	COMPACTION
A	IMPERVIOUS CORE	CL & CH	95% STD. OPT #28
B	UPSTREAM SHELL	CL, SM, SC	90
C	DOWNSTREAM SHELL	CL, SM, SC	90
D	STABILIZING FILL	RANDOM	90% STD. OPT #48
E	FINGER DRAIN	GP & SP	65% RELATIVE DENSITY
F	SLOPE PROTECTION	SOIL CEMENT	95% STD
G	LINEAR DRAIN	GP & SP	65% RELATIVE DENSITY

TYPICAL DAM SECTION
 SCALE: 1"=20'

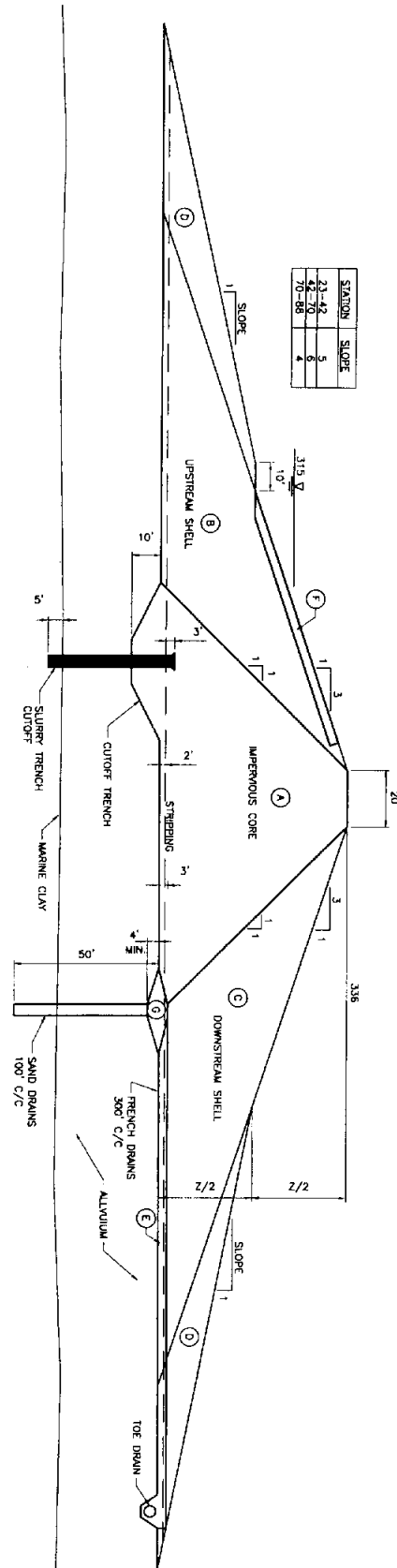

STATION	SLOPE
23+42	5
74+20	4
76+20	4

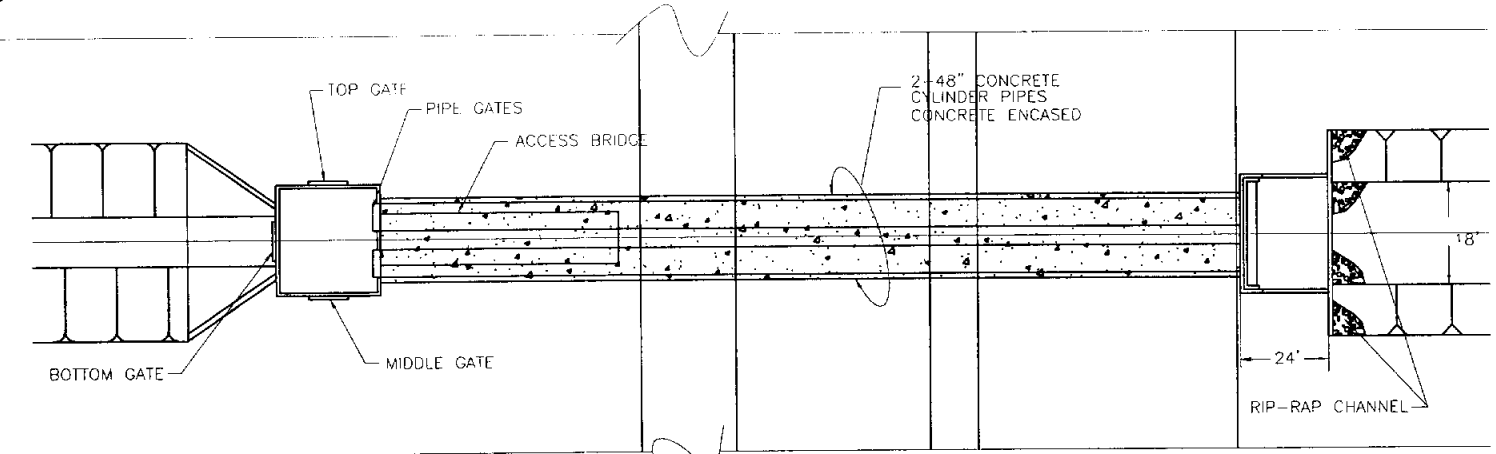

PLAN OF OUTLET WORKS

24' 0
SCALE: 1"=24'

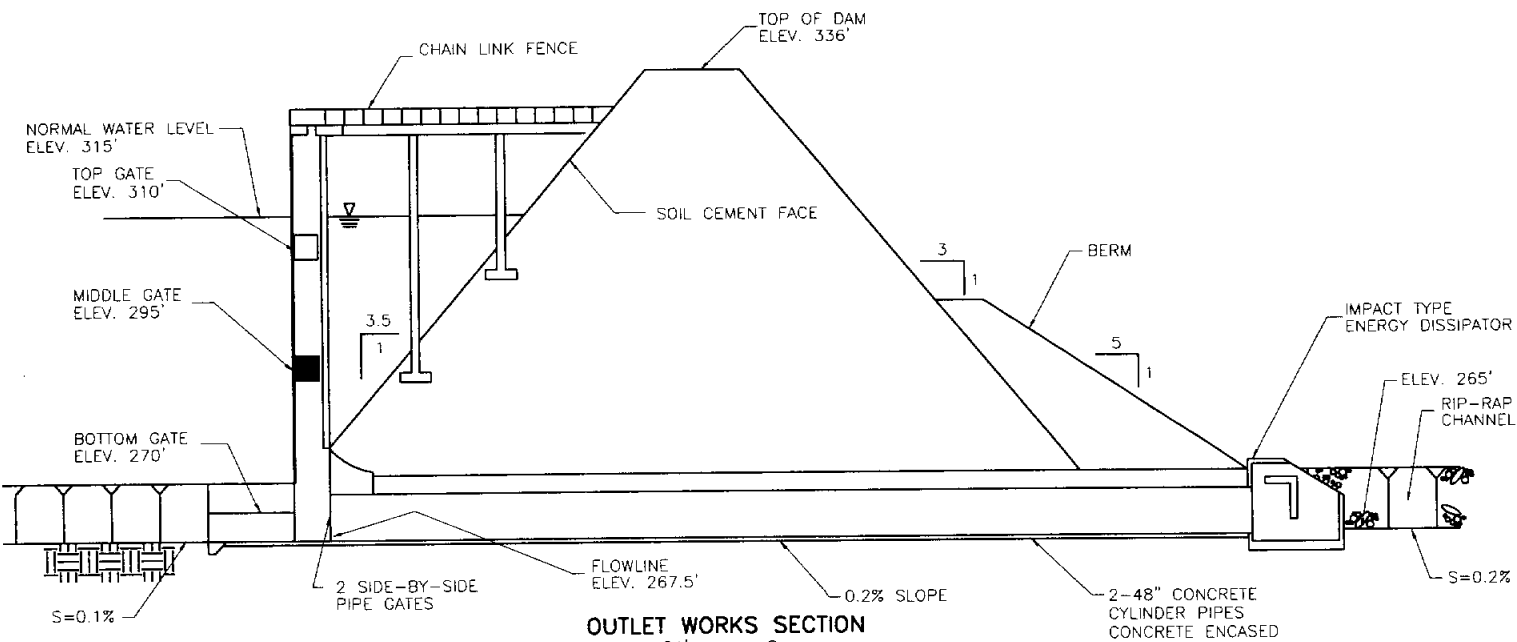

OUTLET WORKS SECTION

24' 0
SCALE: 1"=24'

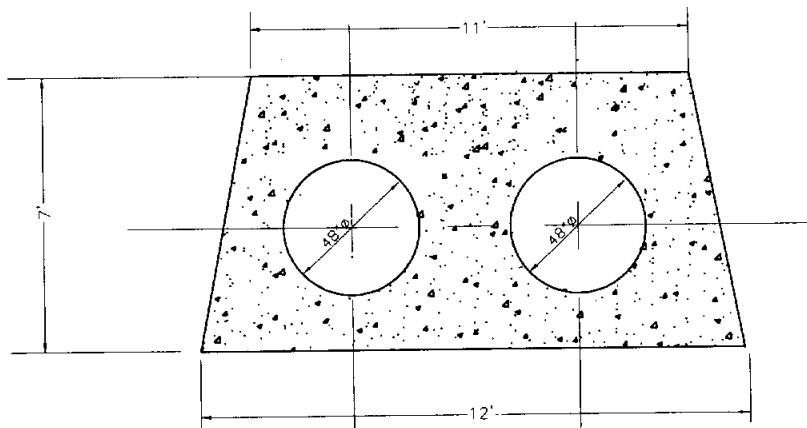

TYPICAL SECTION
NOT TO SCALE

[ANR01289] N:\WR\CV-OUT-PS-OUTW.DWG LAYOUT: Layout1
Mar. 20, 2003 11:50am LTS: 1
REFERENCES: N:\STANDARD\BORDER.DWG



ANGELINA AND NECHES RIVER AUTHORITY
LAKE EASTEX

OUTLET WORKS
PLAN AND PROFILE

F&N JOB NO	ANR01289
DATE	NOV. 2002
SCALE	AS SHOWN
DESIGNED	JCM
DRAFTED	MDC
FILE	CV-OUT-PS-OUTW.DWG

6-11

FIGURE

Table 6-6. Lake Eastex Dam

Embankment	
Type	Rolled Earthfill
Height	67 feet
Maximum Elevation	336 feet NGVD
Length	6,800 feet
Service Spillway	
Control	Uncontrolled Ogee
Width	200 feet
Crest Elevation	315 feet NGVD
Emergency Spillway	
Control	Uncontrolled
Width	1,100 feet
Crest Elevation	324 feet NGVD
Outlet Works	
Type	Two 48-inch conduits
Control	Three sluice gates Elevation 270 feet NGVD, 295 feet NGVD, and 310 feet NGVD

6.4 Geotechnical Analysis

A preliminary geotechnical investigation to help clarify the preliminary design of the embankment was undertaken as part of this effort. This investigation involved six borings along the centerline of the embankment. Some additional sampling and testing of sites was done in potential borrow areas.

6.4.1 Geology

The bedrock formation exposed in the abutments of the dam site is the Queen City Sand of Eocene age. The Queen City Sand is described as “*Quartz sand, fine grained, brownish gray; thin irregular interbeds of light brown to light gray clay; a few glauconite lentils; clay-ironstone beds and concretions common. Sand weathers pale red to grayish orange, clay weathers brownish gray to very light gray, resulting in a distinctive intermixing of colors characteristic of the formation.*”

The Queen City Sand is underlain by the Reklaw Formation, the upper part of which is mostly carbonaceous clay and silt.

Faults roughly paralleling the dam alignment are shown about three quarters of a mile downstream and two miles upstream from the dam site. These faults are part of the Balcones

Fault System. The downstream fault reportedly dips to the northwest and is downthrown to the northwest, whereas the upstream fault is downthrown to the southeast, so the dam site is in a graben. The faults in the region are generally considered to be inactive.

6.4.2 Dam Foundation

A previous feasibility study on the dam (LAN 1991) included a preliminary geotechnical investigation by Rone Engineers, Dallas, Texas. This investigation included three borings and some soil testing. As part of the current investigation, the six additional borings along the dam alignment were completed, along with some laboratory testing.

The borings in the valley show 18 to 28 feet of alluvium underlain by the clays and sands of the Queen City Sand formation. In the abutments the thickness of the alluvium is difficult to determine, but the combined thickness of alluvium and weathered older materials is probably less than 35 feet. The alluvium appears to be primarily firm to very stiff lean clay and loose to medium dense silty and clayey fine-grained sand. A few feet of fat clay was encountered in three of the borings, and a few feet of gravelly sand or gravel was encountered in two borings. The conditions at the right abutment are significantly different than at the other borings. The borings in the right abutment show mostly sand.

The Queen City Sand materials beneath the alluvium include very stiff to hard lean clays and fat clays as well as very dense fine-grained sands. The clays predominate in the valley, where all the borings encountered at least 30 feet of clay. Sand was penetrated a few feet at the bottom of three of the borings, below the clay.

The foundation includes extensive areas underlain by permeable sandy soils that can carry significant quantities of seepage beneath the dam. The geotechnical investigations indicate that these zones are underlain by thick clay deposits that appear to be continuous, except at the right abutment, where the sandy soils extend to nearly 100 feet below the surface of the uplands. The upper foundation soils include some areas with firm to stiff alluvial lean clays and loose silty and clayey sands. These weaker soils are generally limited to the upper 20 feet or less of the profile. The deeper soils are generally very dense or hard.

6.4.3 Embankment Design

Design of the embankment must consider safety, maintenance, and construction cost. Safety requires careful control of seepage through the embankment and foundation, adequate stability of the slopes, and protection against excessive erosion. Maintenance is enhanced by slopes that can be easily mowed, durable wave protection, limited settlement of the embankment and appurtenant structures, and minimization of wet ground conditions. Economical construction requires efficient use of nearby native materials, steeper slopes to minimize quantities, and minimal foundation preparation. Design involves balancing these often-conflicting requirements. The embankment section for Eastex Dam would consist of an earthen fill section with an impervious clay core, a cut-off trench, and a slurry trench to control possible seepage through the sand layers located below the dam. A slurry trench cutoff beneath the dam can provide effective and reasonably economical seepage control. Along most of the embankment length, the slurry trench would need to be approximately 40 feet deep to reach the clay layer below the sand. In the right (southwest) abutment, the surface of the clay appears to be about 40 feet lower, and the cutoff would need to be as much as 100 feet deep.

A zoned section with a clay core and mixed soil shells that make efficient use of the excavated materials will likely be more economical and perform better than a homogeneous section. A clay core with one horizontal to one vertical slopes is recommended. A narrower core might require an expensive downstream chimney drain to lower the phreatic surface and control piping through possible cracks. A wider core would require substituting borrow material for available excavated soil.

The outside section of the dam could be constructed with random fill using the excavated materials from the spillways. The use of three horizontal to one vertical slopes is recommended for ease of maintenance, as well as for stability.

Weak foundation soils can be the controlling factor for slope stability in higher dams. Guidelines recommend stabilizing fills with flatter slopes extending one-half the height of the embankment where weak foundation soils would require flatter slopes than those dictated by the embankment soil types. The slopes of the stabilizing fills are a function of the average consistency and type of soil within a depth equal to the height of the dam. Stabilizing berms can

be built with random available materials, avoiding any soils that may not support vegetation at the downstream face.

Erosion protection of the upstream slope can be provided using a blanket of soil cement about two feet thick. Large quantities of clay suitable for the core and sand suitable for the soil cement are available in the reservoir area within about two miles of the dam.

6.5 Conflict Identification

A large portion of the Lake Eastex area remains undeveloped. There are no towns or cities within the proposed reservoir limits. However, in a project of this size, there will be conflicts which will require modification. As part of the current Planning Studies, Shaumburg and Polk, Inc., identified the potential conflicts and prepared an opinion of probable cost for resolution of the conflicts. A copy of the analysis is included in Volume II. Preliminary analysis of the area for conflicts identified a number of communication utilities, as well as electric utilities. There is also some oil and gas development in the area as well as a waterline. The largest impact will be to the county roads, state highways and the railroad lines in the reservoir area. A summary of the conflicts in the reservoir is included in Table 6-7.

Table 6-7. Conflicts

Category	Item
Communications	Cable
	Fiber Optic Cable
Electric Utilities	Transmission
	Distribution
Oil and Gas	Natural Gas Lines
	Natural Gas Well
	Crude Oil Line
Water	Water Line
Transportation	State Roads
	County Roads
	Railroad

6.5.1 Communication Utilities

Sprint, Verizon, and WorldCom all have communication lines within the reservoir area. There are seven sections of copper, telephone, or fiber optic cable within the lake area. Two sections of telephone line and one section of copper cable will be abandoned. Two sections of copper cable and one section of telephone cable will be rerouted. There are three sections of fiber optic cable. One section will need minor modifications to remain in place. The other sections will be relocated with the State Highway 135 crossing and the Union Pacific Railroad crossing.

6.5.2 Electric Utilities

Cherokee County Electrical Cooperative Association, Oncor Energy Delivery, and Oncor Energy Transmission each have utility lines within the reservoir area. There are four sections of high-voltage transmission lines which currently cross the lake and will need to be modified to provide clearance over the lake. Two sections of distribution line will need to be relocated, and several sections will be abandoned. There are two sections of three phase power which will be relocated. Five sections of single phase will be abandoned and one new section will be added to preserve existing services.

6.5.3 Oil and Gas Utilities

Map Production Company, El Paso Field Services, Seminole Creek, Gulf South, and Dale Resources all have facilities in the area which will need to be modified for the construction of the lake. There are 10 to 15 sections of natural gas pipelines which will need to be modified for construction. In addition there is one natural gas metering station and several natural gas wells which will need to be relocated or modified. There is one crude oil line which will need to be modified or encased.

6.5.4 Water Lines

The Afton Grove Water Supply Corporation has one waterline within the proposed reservoir which will need to be relocated to provide service to several residences.

6.5.5 Transportation

The road and railroad conflicts are the ones which present the biggest challenge and will cost the most. Within the reservoir area there are four state highways which will require modification. In addition there are several sections of county roads within the reservoir which will require realignment. There are six sections of roadway that will be abandoned. Efforts to abandon County Road 2064 have been discussed in the past and are being explored in conjunction with the development of the reservoir. There are two major routes connecting the City of Jacksonville to the City of Troup. Considering this, it is estimated that abandoning the county road could result in savings of approximately \$15 million.

The Union Pacific Railroad has a crossing within the lake area which will need to be realigned and modified with bridge construction. There is an additional crossing at the upper limits of the lake which will be impacted during extreme flood events and will need embankment protection.

6.6 Land Acquisition

Lake Eastex will affect approximately 15,000 acres of land. The following criteria are recommended for the land acquisition:

- Fee simple purchase up to elevation 318 feet NGVD, which is three feet above the conservation pool elevation. This will involve 11,500 acres.
- Purchase of flowage easement up to the 100-year event elevation plus two feet. This will be to elevation 326 feet NGVD and will include an additional 3,000 acres. The flowage easement will limit the type of development and use by permit, but will allow the landowner to retain title to the property.

6.7 Opinion of Probable Construction Cost

Table 6-8 shows the estimated cost of development for the Lake Eastex project. The estimated cost is based on recent experience with similar projects. The 35 percent allowance for engineering and contingencies is intended to cover engineering and construction supervision as

well as unforeseen additional construction costs. The total development cost for Lake Eastex in 2003 construction dollars is estimated to be \$173,854,400.

Table 6-8. Opinion of Probable Construction Cost for the Lake Eastex Project

Dam	Cost
Embankment	\$20,736,200
Internal Drainage	\$445,600
Soil Cement Slope Protection	\$2,394,400
Service Spillway	\$4,381,200
Outlet Works	\$902,800
Miscellaneous Items	\$2,393,800
Engineering and Contingencies	\$10,938,900
Geotechnical Investigations	\$450,000
<i>Subtotal for Dam</i>	<i>\$42,642,900</i>
Conflict Resolution	
Communications	\$1,561,600
Electric Utilities	\$11,142,100
Oil and Gas	\$2,823,800
Water Utilities	\$119,300
State and County Roads ¹	\$32,184,200
Railroad	\$21,237,900
Road and Railroad Erosion Protection	\$2,214,500
Engineering and Contingencies	\$22,602,200
<i>Subtotal for Conflicts</i>	<i>\$93,885,600</i>
Land	
Land and Easement Purchase	\$16,380,000
Survey, Appraisal, Legal costs	\$4,500,000
Contingencies	\$4,176,000
<i>Subtotal for Land</i> ²	<i>\$25,056,000</i>
Environmental/Mitigation ³	\$12,269,900
TOTAL COST FOR FINANCING	\$173,854,400

¹Assumes CR 2064 to be abandoned. Cost for relocation would be an additional \$14,987,300. Other county road costs have been reduced based on expected costs provided by ANRA.

²Land cost provided by ANRA.

³See Section 5 for details.

References

- Bureau of Economic Geology (BEG), The University of Texas at Austin, *Geologic Atlas of Texas, 1967*.
- Bureau of Economic Geology (BEG), The University of Texas at Austin, *Atlas of Salt Domes in the East Texas Basin, 1984*.
- Bureau of Reclamation (BuRec), U.S. Department of the Interior, *Design of Small Dams, 1987*.
- Lockwood, Andrews and Newnam, Inc. (LAN), *Engineering Report on Eastex Reservoir*, prepared for Angelina and Neches River Authority, Houston, Texas, September 1984.
- Lockwood, Andrews and Newnam, Inc. (LAN), *Lake Eastex Regional Water Supply Planning Study*, prepared for Angelina and Neches River Authority, Houston, Texas, August 1991.
- National Weather Service (NWS), National Oceanic and Atmospheric Administration, *Five- to 60-Minute Precipitation Frequency for the Eastern and Central United States, Technical Memorandum NWS HYDRO-35*, Silver Spring, Md., 1977.
- National Weather Service (NWS), Schreiner, Louis C. and Riedel, John T., June 1978. *Probable Maximum Precipitation Estimates, United States, East of the 105th Meridian. Hydrometeorological Report No. 51*, National Oceanic and Atmospheric Administration, U.S. Department of Commerce, Silver Spring, Md., June 1978.
- National Weather Service, Hanson, E.M., Schreiner, L.S., and Miller, J.F., *Application of Probable Maximum Precipitation Estimates, United States, East of the 105th Meridian, Hydrometeorological Report No. 52*, National Oceanic and Atmospheric Administration, U.S. Department of Commerce, Silver Spring, Md., August 1982.
- Soil Conservation Service (SCS), U.S. Department Of Agriculture, Texas Agricultural Experiment Station, *Soil Survey Of Cherokee County, Texas 1959*.
- Texas Water Development Board (TWDB). Report 126, *Engineering Data on Dams and Reservoirs in Texas*, February 1971.
- U.S. Army Corps of Engineers (COE), Hydrologic Engineering Center, *HMR52, Probable Maximum Storm (Eastern United States) User's Manual*, March 1984.
- U.S. Army Corps of Engineers (COE), Hydrologic Engineering Center, *HEC-1 Flood Hydrograph Package*, January 1985.
- U.S. Department of Commerce, Rainfall Frequency Atlas of the United States, Technical Paper No. 40, Weather Bureau, Washington, D.C., 1972.

CONTENTS

	Page
7. PUBLIC COMMUNICATION.....	7-1
7.1. Project Coordination Meetings	7-1
7.2. Lake Eastex Web Site	7-2
7.3. Meetings with State and Federal Agencies.....	7-2

7. PUBLIC COMMUNICATION

The Angelina Neches River Authority's contract with the Texas Water Development Board stipulated that the planning study include meetings and coordination with Lake Eastex Participants and the public to communicate the status of the Lake Eastex Planning Studies. This requirement was fulfilled through project coordination meetings, a publicly accessible web site, and meetings with state and federal resource agencies. The Participants include the cities, counties, industries, and water supply corporations that have supported the Lake Eastex project through funding and contracts to buy water from ANRA when Lake Eastex becomes operational.

7.1. Project Coordination Meetings

Meetings were held with project participants and others throughout the duration of the study. The first meeting was held at the commencement of the project in Jacksonville at the Norman Activities Center on March 20, 2001.

The ANRA hosted a second coordination meeting for Participants in September 2001 at the Jacksonville Convention Center, where Freese and Nichols, Inc. (FNI) and their sub consultant Schaumburg and Polk (S&P) presented information on the scope of the planning study and the overall status of the Lake Eastex project.

In September 2002, at approximately the 50 percent project completion stage, the ANRA hosted the Participants at a third coordination meeting in Jacksonville. FNI and S&P updated the group on the preliminary results and summarized the remaining effort and schedule necessary to complete the planning study.

The fourth and final project coordination meeting was held at ANRA's office in Lufkin on March 12, 2003, at a special session of the ANRA Board of Directors. FNI presented a summary of the draft planning study report at that meeting.

7.2. Lake Eastex Web Site

FNI assisted ANRA with development and maintenance of the Lake Eastex web site, (<http://www.lakeeastex.org>). The site contains general project information; project schedule updates; maps; frequently asked questions and answers; and ANRA contact information. The web site also offers a “Comment” section where the public can submit questions, express concerns, and offer comments or suggestions for consideration as the ANRA develops the Lake Eastex project.

7.3. Meetings with State and Federal Agencies

Several meetings were held with regulatory and natural resource agencies to present project information, obtain comments, and conduct studies. The initial agency meeting was held on November 6, 2001. Participants included the Texas Water Development Board, Texas Commission on Environmental Quality (formerly the Texas Natural Resource Conservation Commission), Texas Parks and Wildlife Department, U.S. Army Corps of Engineers, U.S. Department of Agriculture Natural Resources Conservation Service, U.S. Environmental Protection Agency, and U.S. Fish and Wildlife Service. At that meeting FNI described the scope of the planning study, provided maps and information on the proposed Lake Eastex project, and conducted a field tour of the reservoir site.

The next agency meeting was held at FNI’s office in Fort Worth on December 11, 2001. The same agencies that attended the November meeting were represented at this meeting. The primary purpose of the meeting was to identify methodologies for conducting the terrestrial wildlife habitat study at the Lake Eastex site, reach consensus on the method to use, and identify representatives from each agency to serve on the habitat evaluation team. The U.S. Fish and Wildlife Service’s “Habitat Evaluation Procedures” (HEP) was selected as the methodology to use, and a “HEP Team” was established from the participating agencies.

The HEP Team met on January 16 and February 14, 2002, at the U.S. Fish and Wildlife Service office in Arlington, Texas, to make plans for the HEP field effort. The primary objectives of these meetings were to select the appropriate wildlife species to use in the study,

identify field parameters to measure, develop field data sheets, and set dates for the field effort which was scheduled and conducted during the week of April 22-26, 2002. Follow-up HEP Team meetings were held on December 10, 2002 and January 8, 2003, to discuss and finalize the assumptions for calculating wildlife habitat impacts.

TABLE OF CONTENTS

- Appendix 1. Definitions of Hydrologic and Other Terms
- Appendix 2. Technical Notes on Instream Flow Analyses
- Appendix 3. Red-cockaded Woodpecker Agency Correspondence
- Appendix 4. Determination of HSI Values for HEP Analyses
- Appendix 5. Geotechnical Investigation
- Appendix 6. State Historic Preservation Officer Correspondence
- Appendix 7. TWDB Comments on Draft Report and ANRA Responses

APPENDIX 1 – DEFINITIONS OF HYDROLOGIC AND OTHER TERMS

Source: *USGS Water Basics Glossary* (URL: http://capp.water.usgs.gov/GIP/h2o_gloss) and *US Army Corps of Engineers Wetlands Delineation Manual, Wetlands Research Program Technical Report Y-87-1. (

Acre-foot (acre-ft.) - The volume of water needed to cover an acre of land to a depth of one foot; equivalent to 43,560 cubic feet or 325,851 gallons.

Aerobic * - A situation in which molecular oxygen is a part of the environment.

Anaerobic * - A situation in which molecular oxygen is absent (or effectively so) from the environment.

Aquifer - A geologic formation, group of formations, or part of a formation that contains sufficient saturated permeable material to yield significant quantities of water to springs and wells.

Average discharge - As used by the U.S. Geological Survey, the arithmetic average of all complete water years of record of surface water discharge whether consecutive or not. The term "average" generally is reserved for average of record and "mean" is used for averages of shorter periods, namely, daily, monthly, or annual mean discharges. See also Mean

Backwater - A body of water in which the flow is slowed or turned back by an obstruction such as a bridge or dam, an opposing current, or the movement of the tide.

Backwater flooding * - Situations in which the source of inundation is overbank flooding from a nearby stream.

Bank - The sloping ground that borders a stream and confines the water in the natural channel when the water level, or flow, is normal.

Bank storage - The change in the amount of water stored in an aquifer adjacent to a surface-water body resulting from a change in stage of the surface-water body.

Basal area * - The cross-sectional area of a tree trunk measured in square inches, square centimeters, etc. Basal area is normally measured at 4.5 ft above the ground level and is used as a measure of dominance. The most easily used tool for measuring basal area is a tape marked in square inches. When plotless methods are used, an angle gauge or prism will provide a means for rapidly determining basal area. This term is also applicable to the cross-sectional area of a clumped herbaceous plant, measured at 1.0 in. above the soil surface.

Base flow - The sustained low flow of a stream, usually ground-water inflow to the stream channel.

Basin – See Drainage basin.

Benthic invertebrates - Insects, mollusks, crustaceans, worms, and other organisms without a backbone that live in, on, or near the bottom of lakes, streams, or oceans.

Benthic organism - A form of aquatic life that lives on or near the bottom of streams, lakes, or oceans.

Best management practice (BMP) - An agricultural practice that has been determined to be an effective, practical means of preventing or reducing nonpoint-source pollution.

Biota - All living organisms of an area.

Bottom land - See Flood plain.

Bottom-land forest - Low-lying forested wetland found along streams and rivers, usually on alluvial flood plains.

Braided stream - A stream characterized by an interlacing or tangled network of several small branching and reuniting shallow channels.

- Canopy layer *** - The uppermost layer of vegetation in a plant community. In forested areas, mature trees comprise the canopy layer, while the tallest herbaceous species constitute the canopy layer in a marsh.
- Channel scour** - Erosion by flowing water and sediment on a stream channel; results in removal of mud, silt, and sand on the outside curve of a stream bend and the bed material of a stream channel.
- Channelization** - The straightening and deepening of a stream channel to permit the water to move faster or to drain a wet area for farming.
- Chroma *** - The relative purity or saturation of a color; intensity of distinctive hue as related to grayness; one of the three variables of color.
- Climate** - The sum total of the meteorological elements that characterize the average and extreme conditions of the atmosphere over a long period of time at any one place or region of the Earth's surface.
- Community** - In ecology, the species that interact in a common area.
- Comprehensive wetland determination *** - A type of wetland determination that is based on the strongest possible evidence, requiring the collection of quantitative data.
- Confluence** - The flowing together of two or more streams; the place where a tributary joins the main stream.
- Consumptive use** - The quantity of water that is not available for immediate reuse because it has been evaporated, transpired, or incorporated into products, plant tissue, or animal tissue. Also referred to as "water consumption".
- Contact recreation** - Recreational activities, such as swimming and kayaking, in which contact with water is prolonged or intimate, and in which there is a likelihood of ingesting water.
- Contributing area** - The area in a drainage basin that contributes water to streamflow or recharge to an aquifer.
- Core sample** - A sample of rock, soil, or other material obtained by driving a hollow tube into the undisturbed medium and withdrawing it with its contained sample.
- Cubic foot per second (ft³/s, or cfs)** - Rate of water discharge representing a volume of 1 cubic foot passing a given point during 1 second, equivalent to approximately 7.48 gallons per second or 448.8 gallons per minute or 0.02832 cubic meter per second. In a stream channel, a discharge of 1 cubic foot per second is equal to the discharge at a rectangular cross section, 1 foot wide and 1 foot deep, flowing at an average velocity of 1 foot per second.
- Datum plane** - A horizontal plane to which ground elevations or water surface elevations are referenced.
- Deciduous** - Refers to plants that shed foliage at the end of the growing season.
- Diameter at breast height (DBH) *** - The width of a plant stem as measured at 4.5 ft above the ground surface.
- Direct runoff** - The runoff entering stream channels promptly after rainfall or snowmelt.
- Discharge** - The volume of fluid passing a point per unit of time, commonly expressed in cubic feet per second, million gallons per day, gallons per minute, or seconds per minute per day.
- Dissolved oxygen** - Oxygen dissolved in water; one of the most important indicators of the condition of a water body. Dissolved oxygen is necessary for the life of fish and most other aquatic organisms.
- Diversion** - A turning aside or alteration of the natural course of a flow of water, normally considered physically to leave the natural channel. In some States, this can be a consumptive use direct from another stream, such as by livestock watering. In other States, a diversion must consist of such actions as taking water through a canal, pipe, or conduit.
- Domestic withdrawals** - Water used for normal household purposes, such as drinking, food preparation, bathing, washing clothes and dishes, flushing toilets, and watering lawns and gardens. The water may be obtained from a public supplier or may be self-supplied. Also called residential water use.
- Dominance *** - As used herein, a descriptor of vegetation that is related to the standing crop of a species in an area, usually measured by height, areal cover, or basal area (for trees).

Dominant plant - The plant species controlling the environment.

Dominant species * - As used herein, a plant species that exerts a controlling influence on or defines the character of a community.

Drainage area - The drainage area of a stream at a specified location is that area, measured in a horizontal plane, which is enclosed by a drainage divide.

Drainage basin - The land area drained by a river or stream.

Drained * - A condition in which ground or surface water has been reduced or eliminated from an area by artificial means.

Drawdown - The difference between the water level in a well before pumping and the water level in the well during pumping. Also, for flowing wells, the reduction of the pressure head as a result of the discharge of water.

Drought - A prolonged period of less-than-normal precipitation such that the lack of water causes a serious hydrologic imbalance.

Duration (inundation/soil saturation) * - The length of time during which water stands at or above the soil surface (inundation), or during which the soil is saturated. As used herein, duration refers to a period during the growing season.

Ecoregion - An area of similar climate, landform, soil, potential natural vegetation, hydrology, or other ecologically relevant variables.

Ecosystem - A community of organisms considered together with the nonliving factors of its environment.

Effluent - Outflow from a particular source, such as a stream that flows from a lake or liquid waste that flows from a factory or sewage-treatment plant.

Emergent plant * - A rooted herbaceous plant species that has parts extending above a water surface.

Endangered species - A species that is in imminent danger of becoming extinct.

Environment - The sum of all conditions and influences affecting the life of organisms.

Environmental setting - Land area characterized by a unique combination of natural and human-related factors, such as row-crop cultivation or glacial-till soils.

Ephemeral stream - A stream or part of a stream that flows only in direct response to precipitation; it receives little or no water from springs, melting snow, or other sources; its channel is at all times above the water table.

Erosion - The process whereby materials of the Earth's crust are loosened, dissolved, or worn away and simultaneously moved from one place to another.

Eutrophication - The process by which water becomes enriched with plant nutrients, most commonly phosphorus and nitrogen.

Evaporation - The process by which water is changed to gas or vapor; occurs directly from water surfaces and from the soil.

Evapotranspiration - The process by which water is discharged to the atmosphere as a result of evaporation from the soil and surface-water bodies, and transpiration by plants.

Exotic species - Plants or animals not native to the area.

Fallow - Cropland, tilled or untilled, allowed to lie idle during the whole or greater part of the growing season.

Fecal bacteria - Microscopic single-celled organisms (primarily fecal coliforms and fecal streptococci) found in the wastes of warm-blooded animals. Their presence in water is used to assess the sanitary quality of water for body-contact recreation or for consumption. Their presence indicates contamination by the wastes of warm-blooded animals and the possible presence of pathogenic (disease producing) organisms.

Fecal coliform - See Fecal bacteria.

Flood - Any relatively high streamflow that overflows the natural or artificial banks of a stream.

Flood attenuation - a weakening or reduction in the force or intensity of a flood.

Flood plain - A strip of relatively flat land bordering a stream channel that is inundated at times of high water.

Flooded * - A condition in which the soil surface is temporarily covered with flowing water from any source, such as streams overflowing their banks, runoff from adjacent or surrounding slopes, inflow from high tides, or any combination of sources.

Flow line - The idealized path followed by particles of water.

Fluvial - Pertaining to a river or stream.

Fluvial deposit - A sedimentary deposit consisting of material transported by suspension or laid down by a river or stream.

Frequency (inundation or soil saturation) * - The periodicity of coverage of an area by surface water or soil saturation. It is usually expressed as the number of years (e.g., 50 years) the soil is inundated or saturated at least once each year during part of the growing season per 100 years or as a 1-, 2-, 5- year, etc., inundation frequency.

Frequency (vegetation) * - The distribution of individuals of a species in an area. More than one species may have a frequency of 100 percent within the same area.

Frequently flooded * - A flooding class in which flooding is likely to occur often under normal weather conditions (more than 50-percent chance of flooding in any year or more than 50 times in 100 years).

Freshwater - Water that contains less than 1,000 milligrams per liter of dissolved solids.

Gage height - See Stage

Gaging station - A particular site on a stream, canal, lake, or reservoir where systematic observations of hydrologic data are obtained.

Geomorphic - Pertaining to the form or general configuration of the Earth or of its surface features.

Ground water - In the broadest sense, all subsurface water; more commonly that part of the subsurface water in the saturated zone.

Ground-water flow system - The underground pathway by which ground water moves from areas of recharge to areas of discharge.

Growing season * - The portion of the year when soil temperatures at 19.7 in. below the soil surface are higher than biologic zero (5 °C) (U.S. Department of Agriculture & Soil Conservation Service 1985). For ease of determination this period can be approximated by the number of frost-free days (U.S. Department of the Interior 1970).

Habitat - The part of the physical environment in which a plant or animal lives.

Headwaters - The source and upper part of a stream.

Herb * - A nonwoody individual of a macrophytic species. In this manual, seedlings of woody plants (including vines) that are less than 3.2 ft in height are considered to be herbs.

Herbaceous layer * - Any vegetative stratum of a plant community that is composed predominantly of herbs.

Hue * - A characteristic of color that denotes a color in relation to red, yellow, blue, etc; one of the three variables of color. Each color chart in the Munsell Color Book (Munsell Color 1975) consists of a specific hue.

Hydraulic conductivity - The capacity of a rock to transmit water. It is expressed as the volume of water at the existing kinematic viscosity that will move in unit time under a unit hydraulic gradient through a unit area measured at right angles to the direction of flow.

Hydraulic gradient - The change of hydraulic head per unit of distance in a given direction.

- Hydraulic head** - The height of the free surface of a body of water above a given point beneath the surface.
- Hydric soil** * - A soil that is saturated, flooded, or ponded long enough during the growing season to develop anaerobic conditions that favor the growth and regeneration of hydrophytic vegetation (U.S. Department of Agriculture & Soil Conservation Service 1985). Hydric soils that occur in areas having positive indicators of hydrophytic vegetation and wetland hydrology are wetland soils.
- Hydric soil condition** * - A situation in which characteristics exist that are associated with soil development under reducing conditions.
- Hydrograph** - Graph showing variation of water elevation, velocity, streamflow, or other property of water with respect to time.
- Hydrologic cycle** - The circulation of water from the sea, through the atmosphere, to the land, and thence back to the sea by overland and subterranean routes.
- Hydrologic regime** * - The sum total of water that occurs in an area on average during a given period.
- Hydrologic unit** - A geographic area representing part or all of a surface drainage basin or distinct hydrologic feature as delineated by the U. S. Geological Survey on State Hydrologic Unit Maps. Each hydrologic unit is assigned a hierarchical hydrologic unit code consisting of 2 digits for each successively smaller drainage basin unit.
- Hydrologic zone** * - An area that is inundated or has saturated soils within a specified range of frequency and duration of inundation and soil saturation.
- Hydrology** * - The science dealing with the properties, distribution, and circulation of water.
- Hydrophobic** - Not capable of uniting with or absorbing water.
- Hydrophyte** - Any plant growing in water or on a substrate that is at least periodically deficient in oxygen as a result of excessive water content.
- Hydrophytic vegetation** * - The sum total of macrophytic plant life growing in water or on a substrate that is at least periodically deficient in oxygen as a result of excessive water content. When hydrophytic vegetation comprises a community where indicators of hydric soils and wetland hydrology also occur, the area has wetland vegetation.
- Hydrostatic pressure** - The pressure exerted by the water at any given point in a body of water at rest.
- Impaired** - Condition of the quality of water that has been adversely affected for a specific use by contamination or pollution.
- Importance value** * - A quantitative term describing the relative influence of a plant species in a plant community, obtained by summing any combination of relative frequency, relative density, and relative dominance.
- Index of Biotic Integrity (IBI)** - An aggregated number, or index, based on several attributes or metrics of a fish community that provides an assessment of biological conditions.
- Indicator** * - As used in this manual, an event, entity, or condition that typically characterizes a prescribed environment or situation; indicators determine or aid in determining whether or not certain stated circumstances exist.
- Indicator status** * - One of the categories (e.g., OBL) that describes the estimated probability of a plant species occurring in wetlands.
- Industrial withdrawals** - Water withdrawn for or used for thermoelectric power (electric utility generation) and other industrial and manufacturing uses such as steel, chemical and allied products, paper and allied products, mining, and petroleum refining. The water may be obtained from a public supplier or may be self-supplied.
- Infiltration** - The downward movement of water from the atmosphere into soil or porous rock.
- Instantaneous discharge** - The volume of water that passes a point at a particular instant of time.

- Instream use** - Water use taking place within the stream channel for such purposes as hydroelectric power generation, navigation, water-quality improvement, fish propagation, and recreation. Sometimes called nonwithdrawal use or in-channel use.
- Intermittent stream** - A stream that flows only when it receives water from rainfall runoff or springs, or from some surface source such as melting snow.
- Inundation** * - A condition in which water from any source temporarily or permanently covers a land surface.
- Invertebrate** - An animal having no backbone or spinal column. See also Benthic invertebrate.
- Irrigation** - Controlled application of water to arable land to supply requirements of crops not satisfied by rainfall.
- Irrigation district** - In the United States, a cooperative, self-governing public corporation set up as a subdivision of the state, with definite geographic boundaries, organized to obtain and distribute water for irrigation of lands within the district; created under authority of the State legislature with the consent of a designated fraction of the land owners or citizens and the taxing power.
- Irrigation return flow** - The part of irrigation applied to the surface that is not consumed by evapotranspiration or uptake by plants and that migrates to an aquifer or surface-water body.
- Irrigation withdrawals** - Withdrawals of water for application on land to assist in the growing of crops and pastures or to maintain recreational lands.
- Lacustrine** - Pertaining to, produced by, or formed in a lake.
- Lacustrine wetlands** - Wetlands within a lake or reservoir greater than 20 acres or within a lake or reservoir less than 20 acres if the water is greater than 2 meters deep in the deepest part of the basin; ocean-derived salinity is less than 0.5 part per thousand.
- Limnetic** - The deepwater zone (greater than 2 meters deep); a subsystem of the Lacustrine System of the U.S. Fish and Wildlife Service wetland classification system.
- Littoral** - The shallow-water zone (less than 2 meters deep); a subsystem of the Lacustrine System of the U.S. Fish and Wildlife Service wetland classification system.
- Load** - Material that is moved or carried by streams, reported as weight of material transported during a specified time period, such as tons per year.
- Main stem** - The principal trunk of a river or a stream.
- Marsh** - A water-saturated, poorly drained area, intermittently or permanently water covered, having aquatic and grasslike vegetation.
- Mean** - The arithmetic average of a set of observations, unless otherwise specified.
- Mean discharge (MEAN)** - The arithmetic mean of individual daily mean discharges of a stream during a specific period, usually daily, monthly, or annually.
- Median** - The middle or central value in a distribution of data ranked in order of magnitude. The median is also known as the 50th percentile.
- Mineral soil** * - A soil consisting predominantly of, and having its properties determined predominantly by, mineral matter usually containing less than 20 percent organic matter.
- Mitigation** - Actions taken to avoid, reduce, or compensate for the effects of human-induced environmental damage.
- Monitoring** - Repeated observation, measurement, or sampling at a site, on a scheduled or event basis, for a particular purpose.
- Monitoring well** - A well designed for measuring water levels and testing ground-water quality.
- Mottles** * - Spots or blotches of different color or shades of color interspersed within the dominant color in a soil layer, usually resulting from the presence of periodic reducing soil conditions.

Mouth - The place where a stream discharges to a larger stream, a lake, or the sea.

Muck - Dark, finely divided, well-decomposed, organic matter forming a surface deposit in some poorly drained areas.

National Geodetic Vertical Datum of 1929 - Geodetic datum derived from a general adjustment of first - order level nets of the United States and Canada; formerly called "Sea Level Datum of 1929."

Navigable water - In the context of the Clean Water Act, all surface water.

Noncontact water recreation - Recreational activities, such as fishing or boating, that do not include direct contact with the water.

Nonpersistent emergent plants - Emergent plants whose leaves and stems break down at the end of the growing season from decay or by the physical forces of waves and ice; at certain seasons, there are no visible traces of the plants above the surface of the water.

Nonpoint source - A source (of any water-carried material) from a broad area, rather than from discrete points.

Nonpoint-source contaminant - A substance that pollutes or degrades water that comes from lawn or cropland runoff, the atmosphere, roadways, and other diffuse sources.

Nonpoint-source water pollution - Water contamination that originates from a broad area (such as leaching of agricultural chemicals from crop land) and enters the water resource diffusely over a large area.

Nonwetland * - Any area that has sufficiently dry conditions that indicators of hydrophytic vegetation, hydric soils, and/or wetland hydrology are lacking. As used in this manual, any area that is neither a wetland, a deepwater aquatic habitat, nor other special aquatic site.

Nuisance species - Undesirable plants and animals, commonly exotic species.

Nutrient - Any inorganic or organic compound needed to sustain plant life.

Offstream use - Water withdrawn or diverted from a ground- or surface-water source for use. See also Withdrawal

Overland flow - The flow of rainwater or snowmelt over the land surface toward stream channels.

Oxbow - A bow-shaped lake formed in an abandoned meander of a river.

Palustrine wetlands - Freshwater wetlands including open water bodies of less than 20 acres in which water is less than 2 meters deep; includes marshes, wet meadows, fens, playas, potholes, pocosins, bogs, swamps, and shallow ponds; most wetlands are in the Palustrine system.

Peak stage - Maximum height of a water surface above an established datum plane. Same as peak gage height.

Ped * - A unit of soil structure (e.g., aggregate, crumb, prism, block, or granule) formed by natural processes.

Percolation - The movement, under hydrostatic pressure, of water through interstices of a rock or soil (except the movement through large openings such as caves).

Perennial stream - A stream that normally has water in its channel at all times.

Periodically * - Used herein to define detectable regular or irregular saturated soil conditions or inundation, resulting from ponding of ground water, precipitation, overland flow, stream flooding, or tidal influences that occur(s) with hours, days, weeks, months, or even years between events.

Periphyton - Micro-organisms that coat rocks, plants, and other surfaces on lake bottoms.

Permeability * - A soil characteristic that enables water or air to move through the profile, measured as the number of inches per hour that water moves downward through the saturated soil. The rate at which water moves through the least permeable layer governs soil permeability.

Phytoplankton - See Plankton.

Pioneer plant - Herbaceous annual and perennial seedling plants that colonize bare areas as a first stage in secondary succession.

Plankton - Floating or weakly swimming organisms at the mercy of the waves and currents. Animals of the group are called zooplankton and the plants are called phytoplankton.

Plant community * - All of the plant populations occurring in a shared habitat or environment.

Point source - Originating at any discrete source.

Point-source contaminant - Any substance that degrades water quality and originates from discrete locations such as discharge pipes, drainage ditches, wells, concentrated livestock operations, or floating craft.

Pollutant - Any substance that, when present in a hydrologic system at sufficient concentration, degrades water quality in ways that are or could become harmful to human and/or ecological health or that impair the use of water for recreation, agriculture, industry, commerce, or domestic purposes.

Ponded * - A condition in which water stands in a closed depression. Water may be removed only by percolation, evaporation, and/or transpiration.

Pool - A small part of a stream reach with little velocity, commonly with water deeper than surrounding areas.

Poorly drained * - Soils that commonly are wet at or near the surface during a sufficient part of the year that field crops cannot be grown under natural conditions. Poorly drained conditions are caused by a saturated zone, a layer with low hydraulic conductivity, seepage, or a combination of these conditions.

Population * - A group of individuals of the same species that occurs in a given area.

Positive wetland indicator * - Any evidence of the presence of hydrophytic vegetation, hydric soil, and/or wetland hydrology in an area.

Precipitation - Any or all forms of water particles that fall from the atmosphere, such as rain, snow, hail, and sleet. The act or process of producing a solid phase within a liquid medium.

Prevalent vegetation * - The plant community or communities that occur in an area during a given period. The prevalent vegetation is characterized by the dominant macrophytic species that comprise the plant community.

Reach - A continuous part of a stream between two specified points.

Real-time data - Data collected by automated instrumentation and telemetered and analyzed quickly enough to influence a decision that affects the monitored system.

Regulation (of a stream) - Artificial manipulation of the flow of a stream.

Return flow - That part of irrigation water that is not consumed by evapotranspiration and that returns to its source or another body of water.

Riffle - A shallow part of the stream where water flows swiftly over completely or partially submerged obstructions to produce surface agitation.

Riparian - Pertaining to or situated on the bank of a natural body of flowing water.

Riparian rights - A concept of water law under which authorization to use water in a stream is based on ownership of the land adjacent to the stream. See also Water rights.

Riparian zone - Pertaining to or located on the bank of a body of water, especially a stream.

Riverine wetlands - Wetlands within river and stream channels; ocean-derived salinity is less than 0.5 part per thousand.

Routine wetland determination * - A type of wetland determination in which office data and/or relatively simple, rapidly applied onsite methods are employed to determine whether or not an area is a wetland. Most wetland determinations are of this type, which usually does not require collection of quantitative data.

Runoff - That part of precipitation or snowmelt that appears in streams or surface-water bodies.

- Rural withdrawals** - Water used in suburban or farm areas for domestic and livestock needs. The water generally is self-supplied and includes domestic use, drinking water for livestock, and other uses such as dairy sanitation, evaporation from stock-watering ponds, and cleaning and waste disposal.
- Sample plot** * - An area of land used for measuring or observing existing conditions.
- Sapling/shrub** * - A layer of vegetation composed of woody plants <3.0 in. in diameter at breast height but greater than 3.2 ft in height, exclusive of woody vines.
- Saturated soil conditions** * - A condition in which all easily drained voids (pores) between soil particles in the root zone are temporarily or permanently filled with water to the soil surface at pressures greater than atmospheric.
- Saturated zone** - A subsurface zone in which all the interstices or voids are filled with water under pressure greater than that of the atmosphere. See also Water table.
- Sediment** - Particles, derived from rocks or biological materials, that have been transported by a fluid or other natural process, suspended or settled in water.
- Sedimentation** - The act or process of forming or accumulating sediment in layers; the process of deposition of sediment.
- Seep** - A small area where water percolates (see percolation) slowly to the land surface.
- Shallows** - A term applied to a shallow place or area in a body of water; a shoal.
- Shoal** - A relatively shallow place in a stream, lake, or sea.
- Shrubland** - Land covered predominantly with shrubs.
- Siltation** - The deposition or accumulation of silt (or small-grained material) in a body of water.
- Silviculture** - The cultivation of forest trees.
- Sinuosity** - The ratio of the channel length between two points on a channel to the straight-line distance between the same two points; a measure of meandering.
- Slough** - A small marshy tract lying in a swale or other local shallow, undrained depression; a sluggish creek or channel in a wetland.
- Soil** * - Unconsolidated mineral and organic material that supports, or is capable of supporting, plants, and which has recognizable properties due to the integrated effect of climate and living matter acting upon parent material, as conditioned by relief over time.
- Soil horizon** * - A layer of soil or soil material approximately parallel to the land surface and differing from adjacent genetically related layers in physical, chemical, and biological properties or characteristics (e.g., color, structure, texture, etc.).
- Soil matrix** * - The portion of a given soil having the dominant color. In most cases, the matrix will be the portion of the soil having more than 50 percent of the same color.
- Soil profile** * - A vertical section of a soil through all its horizons and extending into the parent material.
- Soil series** * - A group of soils having horizons similar in differentiating characteristics and arrangement in the soil profile, except for texture of the surface horizon.
- Species** - Populations of organisms that may interbreed and produce fertile offspring having similar structure, habits, and functions.
- Species (taxa) richness** - The number of species (taxa) present in a defined area or sampling unit.
- Species diversity** - An ecological concept that incorporates both the number of species in a particular sampling area and the evenness with which individuals are distributed among the various species.
- Stage** - Height of the water surface above an established datum plane, such as in a river above a predetermined point that may (or may not) be at the channel floor.

- Stream mile** - A distance of 1 mile along a line connecting the midpoints of the channel of a stream.
- Stream order** - A ranking of the relative sizes of streams within a watershed based on the nature of their tributaries. The smallest unbranched tributary is called first order, the stream receiving the tributary is called second order, and so on.
- Stream reach** - A continuous part of a stream between two specified points.
- Stream-aquifer interactions** - Relations of water flow and chemistry between streams and aquifers that are hydraulically connected.
- Streamflow** - The discharge of water in a natural channel.
- Submersed plant** - A plant that lies entirely beneath the water surface, except for flowering parts in some species.
- Substrate** - The surface beneath a wetland, lake, or stream in which organisms grow or to which organisms are attached.
- Surface runoff** - Runoff that travels over the land surface to the nearest stream channel.
- Surface water** - An open body of water such as a lake, river, or stream.
- Swale** - A slight depression, sometimes filled with water, in the midst of generally level land.
- Swamp** - An area intermittently or permanently covered with water, and having trees and shrubs.
- Taxon (plural taxa)** - Any identifiable group of taxonomically related organisms.
- Terrestrial** - Pertaining to, consisting of, or representing the Earth.
- Topography** - The general configuration of a land surface or any part of the Earth's surface, including its relief and the position of its natural and man-made features.
- Transpiration** - The process by which water passes through living organisms, primarily plants, into the atmosphere.
- Tree *** - A woody plant >3.0 in. in diameter at breast height, regardless of height (exclusive of woody vines).
- Tributary** - A river or stream flowing into a larger river, stream or lake.
- Turbidity** - The state, condition, or quality of opaqueness or reduced clarity of a fluid due to the presence of suspended matter.
- Typical *** - That which normally, usually, or commonly occurs.
- Typically adapted *** - A term that refers to a species being normally or commonly suited to a given set of environmental conditions, due to some feature of its morphology, physiology, or reproduction.
- Unconsolidated deposit** - Deposit of loosely bound sediment that typically fills topographically low areas.
- Under normal circumstances *** - As used in the definition of wetlands, this term refers to situations in which the vegetation has not been substantially altered by man's activities.
- Understory** - A foliage layer lying beneath and shaded by the main canopy of a forest.
- Unsaturated zone** - A subsurface zone above the water table in which the pore spaces may contain a combination of air and water.
- Upgradient** - Of or pertaining to the place(s) from which ground water originated or traveled through before reaching a given point in an aquifer.
- Upland *** - As used herein, any area that does not qualify as a wetland because the associated hydrologic regime is not sufficiently wet to elicit development of vegetation, soils, and/or hydrologic characteristics associated with wetlands. Such areas occurring within floodplains are more appropriately termed
- Value (soil color) *** - The relative lightness or intensity of color, approximately a function of the square root of the total amount of light reflected from a surface; one of the three variables of color.

- Vascular plant** - A plant composed of or provided with vessels or ducts that convey water or sap. A fern is an example of this type of plant.
- Vegetation *** - The sum total of macrophytes that occupy a given area.
- Vegetation layer *** - A subunit of a plant community in which all component species exhibit the same growth form (e.g., trees, saplings/shrubs, herbs).
- Water budget** - An accounting of the inflow to, outflow from, and storage changes of water in a hydrologic unit.
- Water column** - An imaginary column extending through a water body from its floor to its surface.
- Water demand** - Water requirements for a particular purpose, such as irrigation, power, municipal supply, plant transpiration, or storage.
- Water exports** - Artificial transfer (by pipes or canals) of freshwater from one region or subregion to another.
- Water imports** - Artificial transfer (by pipes or canals) of freshwater to one region or subregion from another.
- Water rights** - Legal rights to the use of water. See also Riparian rights.
- Water table *** - The upper surface of ground water or that level below which the soil is saturated with water. It is at least 6 in. thick and persists in the soil for more than a few weeks.
- Water year** - A continuous 12-month period selected to present data relative to hydrologic or meteorological phenomena during which a complete annual hydrologic cycle normally occurs. The water year used by the U.S. Geological Survey runs from October 1 through September 30, and is designated by the year in which it ends.
- Watermark *** - A line on a tree or other upright structure that represents the maximum static water level reached during an inundation event.
- Water-quality standards** - State-adopted and U.S. Environmental Protection Agency-approved ambient standards for water bodies. Standards include the use of the water body and the water-quality criteria that must be met to protect the designated use or uses.
- Watershed** - See drainage basin.
- Wetland boundary *** - The point on the ground at which a shift from wetlands to nonwetlands or aquatic habitats occurs. These boundaries usually follow contours.
- Wetland determination *** - The process or procedure by which an area is adjudged a wetland or nonwetland.
- Wetland function** - A process or series of processes that take place within a wetland that are beneficial to the wetland itself, the surrounding ecosystems, and people.
- Wetland hydrology *** - The sum total of wetness characteristics in areas that are inundated or have saturated soils for a sufficient duration to support hydrophytic vegetation.
- Wetland soil *** - A soil that has characteristics developed in a reducing atmosphere, which exists when periods of prolonged soil saturation result in anaerobic conditions. Hydric soils that are sufficiently wet to support hydrophytic vegetation are wetland soils.
- Wetland vegetation *** - The sum total of macrophytic plant life that occurs in areas where the frequency and duration of inundation or soil saturation produce permanently or periodically saturated soils of sufficient duration to exert a controlling influence on the plant species present. As used herein, hydrophytic vegetation occurring in areas that also have hydric soils and wetland hydrology may be properly referred to as wetland vegetation.
- Wetlands *** - Those areas that are inundated or saturated by surface or ground water at a frequency and duration sufficient to support, and that under normal circumstances do support, a prevalence of vegetation typically adapted for life in saturated soil conditions. Wetlands generally include swamps, marshes, bogs, and similar areas.

Withdrawal - Water removed from the ground or diverted from a surface-water source for use. Also refers to the use itself; for example, public-supply withdrawals or public-supply use. See also Offstream use

Yield - The mass of material or constituent transported by a river in a specified period of time divided by the drainage area of the river basin.

Zooplankton - See Plankton.

APPENDIX 2 - TECHNICAL NOTES ON INSTREAM FLOW ANALYSES

Drainage Area

In the 1984 Lockwood, Andrews and Newnam (LAN, 1984) report on Lake Eastex, LAN reported the drainage area of Lake Eastex to be 391 square miles at the dam site. In our study, we found the drainage area to actually be 384 square miles at the dam site (based on digitizing USGS maps, confirmed by USGS gage drainage areas and the WAM ⁽¹⁾).

Runoff

The Neches River WAM inflows were not used in our analyses for two basic reasons:

- Incorrect curve numbers were used in the Neches WAM at the reservoir site and control points.
- Due to limitations in the Water Rights Analyses Package (WRAP) program used in the WAM analysis, Sam Rayburn Reservoir was incorrectly assumed to have a priority call on inflows to Lake Eastex in the WAM studies. This means that Lake Eastex was modeled to release flows to Sam Rayburn to meet Sam Rayburn's water right. The Sam Rayburn water right specifically indicates that Sam Rayburn does not have a priority call on water from the part of the Neches Basin in which Lake Eastex is located. Thus, Sam Rayburn's right cannot force Lake Eastex to bypass inflows for use downstream. (The curve numbers used in the Neches WAM require physically impossible conditions for the watershed between the Mud Creek near Jacksonville USGS gage and the dam site. The result of this error was that the naturalized inflows for Lake Eastex in the WAM were significantly less than the naturalized flows at the upstream gage site, which is not possible in a reach with no channel losses.)

Daily Streamflow Patterns

The monthly runoff data was converted to daily streamflow by the following calculations:

$$\text{Naturalized Daily Streamflow for Yield Studies} = \frac{\text{Monthly Naturalized Runoff} \times \text{Daily Historical Gage Flow}}{\text{Monthly Historical Gage Flow}}$$

Net Evaporation

The following formulas were applied to calculate net evaporation:

$$\text{Precipitation} = (0.26 \times \text{Quadrant 512}) + (0.21 \times \text{Quadrant 513}) + (0.30 \times \text{Quadrant 612}) + (0.23 \times \text{Quadrant 613})$$

$$\text{Gross Evaporation} = (0.26 \times \text{Quadrant 512}) + (0.21 \times \text{Quadrant 513}) + (0.30 \times \text{Quadrant 612}) + (0.23 \times \text{Quadrant 613})$$

$$\text{Runoff Rate} = \frac{\text{Naturalized WAM runoff between Tyler Lakes and Mud Creek near Jacksonville in acre-feet}}{(376 \text{ sq. miles} - 107 \text{ sq. miles}) \times 640 \text{ acres per sq. mile}}$$

$$\text{Net Evaporation} = \text{Gross Evaporation} - \text{Precipitation} + \text{Runoff Rate}$$

Consensus Method Bypass for Lake Eastex

Month	Median Monthly Flow (cfs)	25th Percentile Monthly Flow (cfs)	Annual 7Q2 (cfs)
January	242	112.2	1.9
February	319	157.8	1.9
March	302	161.3	1.9
April	223	119.1	1.9
May	190	73.6	1.9
June	80.2	30.8	1.9
July	31.3	9.6	1.9
August	15.6	2.9	1.9
September	17.1	4.0	1.9
October	25.7	8.1	1.9
November	78.7	37.3	1.9
December	162	65.3	1.9

Note: The median and 25th percentile monthly flows are based on naturalized daily flows. The 7Q2 is based on historical flows

Yield Analyses of Lake Eastex

ACE	Bypass Requirement	Return Flow (MGD)	Maximum Content (ac-ft)	Minimum Content (ac-ft)	Demand (ac-ft/yr)	Critical Period
Original	none	none	195,500	15	79,880	7/1/62-4/18/66
Original	Up to 5 cfs	none	195,500	7	77,600	6/30/62-5/8/69
Original	Up to 10 cfs	none	195,500	37	75,420	6/30/62-1/3/68
Original	consensus method	none	195,500	20	67,600	4/16/61-4/17/66
Original	none	4.66	195,500	18	85,090	7/1/62-4/18/66
Original	Up to 5 cfs	4.66	195,500	14	81,415	6/30/62-4/18/66
Original	Up to 10 cfs	4.66	195,500	22	78,600	6/30/62-4/18/66
Original	consensus method	4.66	195,500	15	71,285	4/16/61-4/17/66
Original	none	9.988	195,500	12	91,040	6/30/62-4/18/66
Original	Up to 5 cfs	9.988	195,500	29	87,360	6/30/62-4/18/66
Original	Up to 10 cfs	9.988	195,500	13	83,690	6/30/62-4/18/66
Original	consensus method	9.988	195,500	37	76,270	4/15/61-4/17/66
After sedimentation	none	none	186,839	12	77,570	6/30/62-4/17/66
After sedimentation	Up to 5 cfs	none	186,839	18	75,380	6/30/62-4/18/66
After sedimentation	Up to 10 cfs	none	186,839	10	73,360	6/30/62-4/18/66
After sedimentation	consensus method	none	186,839	14	65,830	4/15/61-4/17/66
After sedimentation	none	4.66	186,839	16	82,780	6/30/62-4/17/66
After sedimentation	Up to 5 cfs	4.66	186,839	12	79,105	6/30/62-4/17/66
After sedimentation	Up to 10 cfs	4.66	186,839	28	76,290	6/30/62-4/17/66
After sedimentation	consensus method	4.66	186,839	15	69,490	4/15/61-4/17/66
After sedimentation	none	9.988	186,839	15	88730	6/30/62-4/17/66
After sedimentation	Up to 5 cfs	9.988	186,839	30	85050	6/30/62-4/17/66
After sedimentation	Up to 10 cfs	9.988	186,839	10	81380	6/30/62-4/17/66
After sedimentation	consensus method	9.988	186,839	6	74480	4/15/61-4/17/66

INSTREAM FLOW DATA

This section includes information regarding the net evaporation, demand pattern, and the area-capacity-elevation relationships for Lake Eastex. This information was applied in the yield analyses of the reservoir.

Estimated Net Evaporation from Lake Eastex Dam Site

Year	Jan	Feb	Mar	Apr	May	Jun	Jul	Aug	Sep	Oct	Nov	Dec	Total
1940	0.01	-0.18	0.09	-0.20	-0.01	-0.08	0.24	0.16	0.30	0.18	-0.40	-0.09	0.02
1941	0.07	-0.05	0.06	0.03	-0.04	-0.28	0.15	0.30	0.03	-0.25	0.06	0.02	0.10
1942	0.12	0.13	0.12	-0.17	0.06	0.03	0.36	0.00	0.13	0.19	0.14	-0.15	0.96
1943	0.04	0.20	0.01	0.18	-0.13	0.23	0.27	0.51	0.16	0.09	0.07	-0.19	1.44
1944	-0.20	-0.08	0.02	-0.12	-0.10	0.31	0.44	0.14	0.28	0.34	-0.32	-0.21	0.50
1945	0.12	-0.13	-0.19	0.14	0.10	0.01	0.20	0.25	0.22	0.02	0.12	0.07	0.93
1946	-0.18	-0.01	0.01	0.02	-0.20	0.28	0.37	0.20	0.26	0.19	-0.34	0.08	0.68
1947	-0.03	0.14	0.03	0.15	-0.01	0.26	0.47	0.41	0.35	0.30	-0.13	-0.15	1.79
1948	-0.05	-0.04	0.08	0.14	0.03	0.32	0.43	0.50	0.46	0.28	-0.13	-0.03	1.99
1949	-0.44	-0.08	-0.04	-0.02	0.11	0.16	0.09	0.23	0.20	-0.53	0.24	-0.15	-0.23
1950	-0.13	-0.12	0.14	-0.06	-0.18	0.25	0.12	0.35	-0.05	0.22	0.18	0.12	0.84
1951	-0.08	-0.14	0.05	0.20	0.14	0.10	0.35	0.60	-0.12	0.20	-0.01	-0.08	1.21
1952	-0.05	0.03	0.01	-0.12	-0.10	0.35	0.25	0.63	0.55	0.52	-0.26	-0.17	1.64
1953	0.01	-0.08	-0.05	-0.22	-0.07	0.34	0.05	0.26	0.28	0.24	0.01	-0.15	0.62
1954	-0.10	0.23	0.27	0.13	0.00	0.56	0.56	0.56	0.45	-0.23	-0.01	0.03	2.45
1955	-0.06	-0.07	0.21	0.10	0.07	0.37	0.29	0.01	0.28	0.34	0.24	0.05	1.83
1956	-0.08	-0.16	0.17	0.10	0.29	0.35	0.56	0.45	0.47	0.24	-0.07	0.02	2.34
1957	-0.17	-0.15	-0.17	-0.52	0.19	0.14	0.39	0.22	-0.03	-0.46	-0.20	0.00	-0.76
1958	-0.09	0.06	0.03	-0.17	0.38	0.08	0.29	0.12	-0.47	0.12	-0.03	0.05	0.37
1959	0.07	-0.14	0.20	-0.08	0.39	0.17	0.00	0.25	0.18	-0.03	0.01	-0.21	0.81
1960	-0.06	0.03	0.24	0.22	0.33	0.06	0.42	0.07	0.05	-0.05	-0.10	-0.17	1.04
1961	0.04	0.01	0.06	0.38	0.27	-0.22	0.10	0.32	0.05	0.20	-0.17	-0.23	0.81
1962	-0.07	0.10	0.19	0.01	0.39	0.05	0.47	0.51	-0.01	0.10	-0.13	-0.03	1.58
1963	0.06	0.08	0.27	0.02	0.23	0.24	0.34	0.50	0.25	0.42	-0.06	-0.11	2.24
1964	-0.03	-0.02	-0.01	-0.07	0.15	0.40	0.55	0.25	0.09	0.30	-0.01	-0.03	1.57
1965	-0.10	-0.22	-0.01	0.33	-0.28	0.27	0.55	0.40	0.05	0.23	0.03	-0.27	0.98
1966	-0.19	-0.17	0.23	-0.09	0.18	0.47	0.42	-0.01	0.07	0.11	0.17	-0.10	1.09
1967	0.10	0.04	0.25	0.01	-0.15	0.40	0.25	0.46	0.06	0.12	0.11	-0.26	1.39
1968	-0.33	0.00	0.07	-0.14	0.05	-0.06	0.27	0.43	-0.12	0.18	-0.23	-0.04	0.08
1969	0.07	-0.12	0.03	0.07	-0.01	0.45	0.50	0.43	0.26	-0.04	-0.06	-0.16	1.42
1970	0.09	-0.13	0.12	0.07	0.14	0.31	0.31	0.31	-0.01	-0.26	0.11	0.06	1.12
1971	0.17	0.06	0.31	0.29	0.10	0.41	0.24	0.16	0.16	0.02	-0.03	-0.31	1.58
1972	-0.17	0.21	0.20	0.20	0.27	0.17	0.21	0.37	0.08	-0.18	-0.11	-0.11	1.14
1973	-0.17	0.08	-0.11	-0.04	0.26	0.06	0.30	0.41	-0.17	-0.14	0.05	0.01	0.54
1974	-0.21	0.25	0.31	0.21	0.14	0.25	0.43	0.00	-0.27	0.03	-0.10	0.02	1.06
1975	0.06	0.02	0.06	0.02	-0.03	0.17	0.35	0.34	0.25	0.12	0.06	0.01	1.43
1976	0.06	0.12	-0.04	0.02	-0.05	0.22	0.19	0.39	0.01	0.00	0.07	-0.08	0.91

Estimated Net Evaporation from Lake Eastex Dam Site

Year	Jan	Feb	Mar	Apr	May	Jun	Jul	Aug	Sep	Oct	Nov	Dec	Total
1977	-0.04	0.16	0.04	0.18	0.31	0.19	0.42	0.14	0.16	0.24	-0.09	0.06	1.77
1978	-0.27	-0.03	0.15	0.28	0.15	0.36	0.46	0.39	0.06	0.27	-0.26	-0.12	1.44
1979	-0.31	-0.15	0.06	0.15	-0.15	0.43	0.04	0.26	-0.03	0.16	0.00	-0.10	0.36
1980	0.00	0.21	0.03	0.27	0.04	0.41	0.56	0.55	0.21	0.20	-0.03	0.10	2.55
1981	0.05	0.00	0.10	0.22	-0.21	-0.04	0.25	0.36	0.12	-0.22	0.05	0.15	0.83
1982	-0.04	0.03	0.09	0.06	0.13	-0.01	0.37	0.43	0.33	-0.07	-0.23	-0.26	0.83
1983	0.18	0.08	0.09	0.37	-0.08	0.13	0.38	0.15	0.26	0.19	-0.07	-0.17	1.51
1984	-0.01	-0.04	0.20	0.36	0.19	0.29	0.40	0.35	0.24	-0.58	-0.02	0.01	1.39
1985	0.01	-0.07	0.08	0.15	0.23	0.40	0.22	0.55	0.20	-0.42	-0.22	0.09	1.22
1986	0.18	0.00	0.33	-0.07	-0.16	0.05	0.52	0.32	0.04	-0.15	-0.32	-0.10	0.64
1987	0.13	-0.20	0.33	0.41	0.02	0.09	0.26	0.41	0.08	0.21	-0.36	-0.43	0.95
1988	0.19	0.01	-0.04	0.25	0.41	0.41	0.27	0.38	0.31	0.02	-0.08	-0.15	1.98
1989	-0.21	0.13	-0.10	0.47	-0.06	-0.22	0.23	0.37	0.24	0.17	0.14	0.05	1.21
1990	-0.35	0.08	-0.16	0.10	0.04	0.41	0.27	0.39	0.11	0.04	-0.09	-0.18	0.66
1991	-0.23	-0.09	0.20	-0.20	0.17	0.22	0.40	0.15	0.16	0.15	-0.04	-0.21	0.68
1992	-0.04	0.09	0.21	0.24	0.06	0.19	0.33	0.31	0.18	0.10	-0.18	-0.30	1.19
1993	-0.13	-0.03	0.10	0.10	0.15	0.15	0.81	0.58	0.38	-0.09	-0.01	0.04	2.05
1994	-0.01	-0.10	0.18	0.17	-0.11	0.30	0.30	0.23	0.33	-0.41	0.08	-0.18	0.78
1995	0.25	0.11	0.22	0.09	0.22	0.30	0.25	0.27	0.08	0.28	0.15	-0.14	2.08
1996	0.12	0.27	0.22	0.18	0.38	0.19	0.23	-0.03	0.00	0.14	-0.15	-0.05	1.50

Area-Capacity-Elevation of Lake Eastex - Original Conditions

Elevation	Area (Acres)	Capacity (Acre-Feet)
269	0	0
270	125	312
271	250	750
272	400	1,250
273	530	2,000
274	680	2,750
275	830	3,625
276	1,000	4,500
277	1,160	5,250
278	1,320	6,875
279	1,500	7,750
280	1,655	9,210
281	1,820	10,750
282	2,000	12,750
283	2,200	14,750
284	2,370	17,000
285	2,550	19,250
286	2,700	21,500
287	2,920	24,625
288	3,100	27,750
289	3,280	30,750
290	3,469	34,830
291	3,700	37,750
292	3,900	41,750

Elevation	Area (Acres)	Capacity (Acre-Feet)
293	4,110	45,750
294	4,330	50,000
295	4,550	54,750
296	4,760	59,500
297	4,990	64,000
298	5,200	69,250
299	5,440	74,500
300	5,648	80,418
301	5,890	85,750
302	6,115	91,750
303	6,400	98,250
304	6,640	104,500
305	6,910	111,250
306	7,170	118,250
307	7,430	125,750
308	7,710	133,250
309	8,000	141,500
310	8,269	150,005
311	8,640	157,250
312	8,990	166,000
313	9,310	176,250
314	9,640	185,250
315	10,000	195,500

Area-Capacity-Elevation of Lake Eastex – Conditions After 100 Years of Sedimentation

Elevation	Area (Acres)	Capacity (Acre-Feet)
270	0	0
271	0	0
272	150	500
273	280	875
274	410	1,375
275	550	1,875
276	700	2,625
277	850	3,250
278	1,000	4,250
279	1,170	5,000
280	1,322	6,232
281	1,500	7,500
282	1,700	9,250
283	1,870	10,750
284	2,160	12,500
285	2,240	15,000
286	2,430	17,250
287	2,630	19,750
288	2,800	22,250
289	3,000	25,000
290	3,197	28,827
291	3,420	31,750
292	3,650	35,250

Elevation	Area (Acres)	Capacity (Acre-Feet)
293*	3,880	38,700
294	4,090	42,750
295	4,320	47,000
296*	4,540	51,750
297*	4,800	56,250
298	5,030	60,750
299	5,280	66,500
300	5,528	72,455
301	5,740	78,000
302	6,010	83,500
303	6,270	90,250
304	6,540	97,000
305	6,810	103,500
306	7,080	111,250
307	7,350	118,250
308	7,640	125,000
309	7,930	133,250
310	8,256	141,377
311	8,560	148,750
312	8,800	157,500
313	9,240	167,000
314	9,600	176,500
315	10,000	186,839

* LAN reported the capacity at elevation 293 as 32,000, which is less than the capacity at elevation 292. The capacity was adjusted using the curve fitting method. The capacities at elevations 296 and 297 were also adjusted using the curve fitting method.

APPENDIX 3 - RCW AGENCY CORRESPONDENCE

USFWS letter dated February 22, 2002, Re: RCW Habitat Parameter Survey at Lake Eastex

TPWD letter dated June 5, 2002, Re: Potential RCW Habitat Near Lake Eastex



United States Department of the Interior

FISH AND WILDLIFE SERVICE

Ecological Services
WinSystems Center Building
711 Stadium Drive, Suite 252
Arlington, Texas 76011

2-12-02-I-214

February 22, 2002

Mr. Karl W. Hoffman
Freese and Nichols, Inc.
4055 International Plaza, Suite 200
Fort Worth, Texas 76109-4895

Dear Mr. Hoffman:

This responds to your February 6, 2002, request for information related to specific habitat parameters for red-cockaded woodpecker (RCW) presence/absence surveys associated with the proposed Lake Eastex Reservoir site in Cherokee County, Texas.

Your letter references a 1993 endangered species report prepared by Texas Parks and Wildlife Department (TPWD) on this project detailing potentially suitable RCW habitat, and your comparison with 2001 aerial photographs of the project area. It appears that you have concluded that RCW presence/absence surveys are not needed because *"It appears that some of the potential RCW habitat sites identified in the report may have been selectively harvested for pine in the intervening years and may no longer be potential habitat."* Without the benefit of reviewing the TPWD report, we can only suggest that the conditions of these areas be ground-truthed, and if potentially suitable RCW habitat remains, a survey should be conducted as detailed in your endangered species permit (TE024791-1). Since these are private lands, we are not familiar with the areas in question. We suggest you coordinate with Mr. Ricky Maxey of TPWD in Nagogdoches, Texas, (936-564-0234) prior to conducting surveys, since he may be familiar with current habitat conditions of the private lands within the project area.

Should you have any specific questions about the Eastex Reservoir Project, please contact Fish and Wildlife Biologist Mike Armstrong at (817) 277-1100. Additional questions specific to the RCW should be directed to Fish and Wildlife Biologist Jeffrey A. Reid of my staff at (936) 639-8546.

Sincerely,

Thomas J. Cloud, Jr.
Field Supervisor

cc: Jeffrey A. Reid, FWS, Lufkin, Texas



Wildlife Diversity Biologist
Wildlife Division – Region 3 – East Texas
P. O. Box 4655, SFA Station
Nacogdoches, Texas 75962

COMMISSIONERS

KATHARINE ARMSTRONG IDSAL
CHAIRMAN, SAN ANTONIO

ERNEST ANGELO, JR.
VICE-CHAIRMAN, MIDLAND

JOHN AVILA, JR.
FORT WORTH

JOSEPH B.C. FITZSIMONS
SAN ANTONIO

ALVIN L. HENRY
HOUSTON

PHILIP MONTGOMERY
DALLAS

DONATO D. RAMOS
LAREDO

KELLY W. RISING, M.D.
BEAUMONT

MARK E. WATSON, JR.
SAN ANTONIO

LEE M. BASS
CHAIRMAN-EMERITUS
FORT WORTH

ROBERT L. COOK
EXECUTIVE DIRECTOR

June 5, 2002

Karl Hoffman
Environmental Scientist
Freese and Nichols Incorporated
4055 International Plaza, Suite 200
Fort Worth, Texas 76109-4895

Dear Mr. Hoffman:

This letter is written in response to your request for information concerning current potential endangered Red-cockaded Woodpecker (*Picoides borealis*) habitat within and nearby the proposed Lake Eastex site in Cherokee County, Texas. I have reviewed the maps you provided of the project site, and the previous Texas Parks and Wildlife Department evaluation of the project area by Melissa Parker.

Ms. Parker's 1993 report concerning potential impacts upon rare animal and plant species was fairly thorough with exception of a few tracts containing potentially suitable RCW habitat that needed to be surveyed. Those tracts have not been surveyed to-date by the Department, so I can't say that there are no RCW present. Further, I would recommend that any of those sites that contain potentially suitable RCW habitat should be surveyed in conjunction with planning efforts for this project.

Ms. Parker also mentions the area just below the project site that contains the rare plant Neches River rose-mallow (*Hybiscus dasycalyx*). This plant has been listed by the U. S. Fish and Wildlife Service as a candidate species under the Endangered Species Act. This plant appears to prefer periodically disturbed wetland sites along the course of streams and drainages, and it appears to really prefer the margins of these wetland areas. A survey of Mud Creek and the adjoining drainages would identify any additional areas where these plants may occur, and allow consideration for conservation strategies for these plants including relocation. In addition, reservoir management impacts upon existing sites below the reservoir should be considered as well. I

*Give Thanks for
the Memories...*



Lone Star Legacy.

*Give to the
Lone Star Legacy
Endowment Fund*

have enclosed some information on these plants, and recommend consultation with Ms. Kathy Nernec of the U. S. Fish and Wildlife Service at 281/286-8282.

I hope this information is helpful to you in evaluating potential impacts of the project on rare animal and plant species, particularly Red-cockaded Woodpecker and Neches River rose-mallow. Please contact me at 936/564-0234, or by e-mail at rmaxey@sfasu.edu, if I can provide additional information or assistance.

Sincerely,

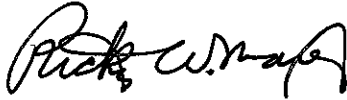
A handwritten signature in black ink, appearing to read "Ricky W. Maxey". The signature is fluid and cursive, with the first name "Ricky" being more prominent and stylized.

Ricky W. Maxey
Wildlife Diversity Biologist



Species: Neches River rose-mallow (*Hibiscus dasycalyx*)

Ecoregions of Occurrence in Texas: Pineywoods.

Counties of Known Occurrence (Present and Historic): Cherokee, Harrison, Houston and Trinity Counties.

Federal Status: Candidate for Listing.

State Status: None.

Recovery Plan(s): None.

Description: Buerennial herb growing 0.8-2.3m (2.6-7.6 ft) in height. Leaves are triangular and deeply 3-lobed, each lobe 3-8mm wide. Flowers produced in leaf axils near tips of branches, petals white to cream colored, usually with some reddish coloration near base; sepals densely covered with long hairs. Seeds densely reddish and hairy.

Habitat: Endemic to wetlands. Occurs in open habitats in seasonally wet soils, most often near standing water as opposed to flowing water. Plants are normally immersed during late-winter and early-spring, but surface soils may be relatively dry by late-summer, although with groundwater present at depths of less than 1.5m. The species likely occurred originally on the banks of sloughs, oxbows, and depositional shores or rivers, streams and associated wetlands.

Natural History: Budding and leafing normally late-March to early-April, but delayed if water depths are more than 3 dm over plants. Flowers normally early-June to late-October, unless heavy spring flooding has occurred. Mature fruits observed July through November. Appears to be erratic in flower production, with generally few flowers open

at any given time, combined with small numbers of plants. Most populations are subdivided into subpopulations due to their propensity to grow near vernal pools which are often separated from other pools. Seeds remain buoyant in water for several hours, so floods are likely the major dispersal mechanism, although bumblebees have been observed visiting the flowers.

Threats and Reasons for Concern: Possible threats to the species include mowing, discing, bulldozing, herbicide use, loss of water supply, genetic swamping, herbivory, disease, and potentially over-collecting. A 1994 status survey by Dr. Mike Warnock of Sam Houston State University found the species to be extremely restricted in range and vulnerable to loss.

Conservation Measures: (1). Protect the hydrology of known sites; (2). Maintain herbaceous growth and control shrubby growth with some form of regular disturbance; (3). Avoid use of herbicides during the plant's growing season; (4). Avoid over-collecting of the plant for purely aesthetic reasons; (5). Protect known sites of occurrence; and (6). Continue cooperative genetics research; and (7). Continue annual cooperative monitoring of the species.

Neches River rose-mallow [*Hibiscus dasycalyx*]

Mallow family (Malvaceae)

Candidate species

Found in Texas only - Houston, Trinity, and Cherokee counties

Shrub-like but perennial herb growing 3-7 feet tall; one or more stems per clump, fairly erect, often branched, cylindrical in shape; stems not pubescent.

LEAVES:

- o alternate on stem, simple, light- to dark-green; petioles 1-2 inches long.
- o not pubescent.
- o 2-4 inches long and 1-4 inches wide at base.
- o deeply 3-lobed and arrowhead-shaped, with basal lobes turned outward.
- o lobes linear and slenderly tapering, 0.1-0.2 inch wide; margins irregularly cut or saw-toothed.
- o early leaves may be eaten by caterpillars by late-June to mid-August, but new leaves are soon produced which suffer little herbivory.

FLOWERS:

- o in leaf axils near tips of branches.
- o large and showy (about 3-6 inches wide); white with red or purple center.
- o bracteoles: 12 in number, to 0.6 inches long, linear or slenderly tapering; inner surface and margins densely pubescent, outside less pubescent.
- o calyx: 5 sepals 1-1.5 inch long, fused marginally to form bell-shaped tube; densely pubescent with long-white hairs on inner surface.
- o petals: 5 in number, 2-4 inches long; about 2 inches wide near tip, less than 0.5 inch wide near base.
- o pistil: fused style 1.5-2.5 inches long, tipped with 5 round stigmas, ovary pubescent.
- o stamen: filaments fused around style, with uppermost tips separating to form bottle-brush structures 1-1.5 inches high; anthers pinkish, pollen pink to white and spiny.
- o **FLOWERS present June-August** (initiation may be delayed if water levels are high; numbers may be reduced by dry conditions).
- o flower production may be erratic, with generally few flowers open at any given time; blossoms tend to close at night (and possibly when disturbed) and open in sunlight.

FRUITS:

- o 0.5-1 inch long, rounded capsule with pointed tip containing 2 rows of seeds, 7-11 seeds per row.
- o splits open to release tiny seeds densely covered with brown-to-reddish hairs; seeds buoyant in water for several hours and may be primary method of dispersal.
- o **FRUITS generally present July-November.**

NOTE: To recover this species, new populations must be found. If you believe you have the species on your land and wish to protect it, please contact Kathy Nemecek of the U.S. Fish and Wildlife Service (281-286-8282). Financial support for landowners may be possible.

APPENDIX 4 – DETERMINATION OF HSI VALUES FOR HEP ANALYSES

The following sections describe any exceptions or assumptions made regarding how HSI values were calculated. In some instances measurements or observations pertinent to a variable (i.e., summer conditions with spring sampling) could not be made and the treatments of these data gaps are described for each species below.

Barred Owl

Field data were collected for the Barred Owl HSI Model (Allen 1987) variables in the BLH and upland forest cover types. Variable averages were used to calculate reproductive suitability indices according to the procedure provided in Allen (1987). The SIR is equivalent to the final HSI value for each cover type.

Belted Kingfisher

Field data were collected for the Belted Kingfisher HSI Model (Prose 1985) variables in the riverine cover type. Variable averages were used to calculate three requisite indices. The Water Life Requisite (SIW) was calculated with the assumption that neither the lacustrine nor the riverine cover type habitats are constantly subject to severe wave action. Also calculated were the Cover Requisite value and Reproduction Requisite Value. The final HSI for each cover type was the lower of the three requisite indices.

Two field variables, water turbidity (V2) and availability of perch sites (V6), were taken from the February 1980 Review Copy Belted Kingfisher HSI Model. The 1980 Review Copy V2 data are categorical water turbidity parameters as opposed to the Secchi disk measurement data used in the 1985 Model for V2. The V6 perch site availability data for the 1980 Review Copy Model are much easier to gather in the field than is estimating the average number of lentic shoreline or stream subsections that contain one or more perches. It was assumed that an “abundant” number of perch sites would be equivalent to “many and adjacent” perch sites (category 5), and that an average between two scores of “many and adjacent” perch sites and one score of “few and adjacent” (category 3) would equal a mode average of category 5.

Category 4, “many, none adjacent,” results in a lower SI value than either category 3 or category 5.

Downy Woodpecker

Field data were collected for the Downy Woodpecker HSI Model (Schroeder 1982) variables in the deciduous forested wetland and upland forest cover types. Variable averages were entered into Suitability Index Curves to obtain SI values. SI1 represents the Food Requisite value, while SI2 represents the Reproduction Requisite value. The final HSI value for each cover type equals the lowest Life Requisite value for that cover type.

Eastern Meadowlark

Field data were collected for the Eastern Meadowlark HSI Model (Schroeder and Sousa 1982) variables in the grassland cover type at the proposed Lake Eastex project area. Variable averages were entered into Suitability Index Curves to obtain SI values. The Food/Reproduction Life Requisite value was obtained using all five SI values in the calculation provided by the model. This value represents the final Eastern Meadowlark HSI value for the Grassland cover type.

Green Heron

Field data were collected for the Green Heron HSI Model (author unknown 1980) variables in the deciduous forested wetland, herbaceous wetland, shrub wetland, and riverine cover types. Variable averages were entered into Suitability Index Curves to obtain SI values. Appropriate SI values were used to obtain Food Requisite, Water Requisite, and Reproductive Requisite values, according to the calculations provided by the model. The final HSI value for each cover type equals the lowest Life Requisite value for that cover type.

Several assumptions were made concerning variables that were not readily measurable in the field. Water current (average summer conditions) data (V6), for example, were not available at every deciduous forested wetland, shrub wetland, or riverine site. Where data were lacking, it was assumed that the current would be moderately slow (category 2), resulting in a SI value of 1.0. Distance to deciduous forested or deciduous shrub wetland (V7) was assumed to

be 0.25 miles for the lacustrine and riverine cover types, giving an SI value of 1.0. Water regime (V5) conditions of semi-permanent water (category 2) were assumed in the shrub wetland cover type, giving an SI value of 0.9.

Red-tailed Hawk

Field data were collected for the red-tailed hawk HSI model (author 1980) in the upland forest, grassland, and shrubland cover types. The red-tailed hawk HSI model is a multi cover model with the following conditions and assumptions.

1. The cover types listed for the Red-tailed Hawk HSI Model within the Lake Eastex study area provide both life requisites (food and cover/reproductive).
2. Life Requisite Values were computed for each cover type using the appropriate variables and aggregate functions provided by the model.
3. Because no cover types within the study area are missing life requisites, Life Requisite SI values were adjusted using Relative Area values rather than by using Spatial Relationship Indices.
4. Relative Area (relative abundance) of each cover type was determined by dividing the area of each cover type by the total area of cover types listed in the Red-tailed Hawk HSI Model.
5. Life Requisite Support by Cover Type values for the food requisite were determined by using the adjusted life requisite values from Step 3 in the life requisite aggregation functions from Step 2. Cover/reproduction Requisite Support values are equivalent to the adjusted cover/reproduction requisite values. The food and cover/reproduction Life Requisite Support values were summed to determine the Total Life Requisite Support values.
6. Actual Life Requisite Values were computed by dividing the Total Life Requisite Support Values by the minimal Optimal Percent Estimates provided by the model. The Final Red-tailed Hawk HSI Value for the Lake Eastex project area equals the lower of the Actual Life Requisite Values.

Wood Duck

Field measurements were collected for the wood duck HSI model (Sousa and Farmer 1983) at the deciduous forested wetland, herbaceous wetland, shrub wetland, and riverine cover types. The wood duck HSI model is a multi cover model with the following conditions and assumptions.

Breeding HSI Model

Field data were entered into the proper suitability index (SI) curves and the index values SI1 and SI2 were used in the supplied equation to calculate V3 (density of potential nest sites/acre). Variables V4 and V5 (% water surface covered by potential brood cover and potential winter cover, respectively) received values of 0% at most Bottomland Hardwood and Riverine sites. If used, these values would have resulted in final HSI values of 0.0 for these two cover types. Instead, values of 25% were substituted for the 0% values, resulting in SI values of 0.5.

1. The Percent Relative Area for each cover type within the study area was calculated by dividing the area of each cover type listed in the Wood Duck HSI model by the combined area of all appropriate cover types and multiplying each result by one hundred.
All cover types in the study area provided both nesting and brood-rearing habitat, so using Variable 6 (V6) to compute an Average Interspersion Index to estimate the juxtaposition of resources was unnecessary.
2. Calculating the Percent Useable Relative Area of each cover type using an Average Interspersion Index was unnecessary. Instead, the Percent Relative Area of each cover type was used.
3. The Percent Area in Optimal Condition values for Nesting and Brood-rearing Habitat were determined by multiplying the Percent Relative Area of each cover type by the life requisite values for that cover type and summing the Adjusted Area products across each cover type for each life requisite.
4. Overall Life Requisite Values for Nesting and Brood-rearing were determined by entering the Percent Area in Optimal Condition values for Nesting and Brood-rearing into the SI curves for V7 and V8, respectively.
5. The lower of the two values calculated in Step 6 represents the Breeding Suitability Value for the Lake Eastex project area.

Winter HSI Model:

The winter HSI for the wood duck in a specific cover type equals the SI value calculated from the average of V5 for that cover type. The SI5 values were summed for all appropriate cover types and divided by the total area of those cover types to obtain the Overall Winter Habitat Life Requisite Value.

Year-round Use Areas:

The wood duck is a resident species in East Texas (Stokes 1996), so an overall HSI value was calculated for the Lake Eastex project area. The Overall Winter Habitat Life Requisite Value was compared to the single HSI determined for Breeding Habitat; the higher of the two values was used to represent the Year-round Wood Duck HSI Value for the Lake Eastex project area.

Eastern Cottontail

Field variables were measured for the eastern cottontail HSI model (Allen 1984) in the upland forest, grassland, and shrubland cover types. The eastern cottontail HSI model is a multi cover model with the following conditions and assumptions.

Winter Cover/Food Index Value

1. The proposed Lake Eastex project area was delineated (stratified) into cover types using remote sensing and GIS technology. Listed cover types for the Eastern Cottontail HSI model include grassland, upland forest, and shrubland.
2. Relative Cover Type Area was calculated by dividing the area of each cover type by the total area of all relevant cover types.
3. Equation 1 was used to determine the Winter Food/Cover Index (WCFI) for each cover type.
4. Adjusted Relative Cover Type Areas were calculated by multiplying the Relative Area of each cover type by the WCFI value for each cover type.
5. The products from step 4 (Adjusted Relative Cover Type Areas) were summed to obtain the Weighted WCFI Value (Final Eastern Cottontail HSI Value) for the Lake Eastex project area.

Fox Squirrel

Field data were collected for the Fox Squirrel HSI Model (Allen 1982a) variables in the deciduous forested wetland and upland forest cover types. Variable averages were entered into Suitability Index Curves to obtain SI values. The appropriate SI values were used to obtain Winter Food and Cover/Reproduction Life Requisite values according to the calculations

provided by the model. The final HSI value for each cover type equals the lowest Life Requisite value for that cover type.

Gray Squirrel

Field data were collected for the Gray Squirrel HSI Model (Allen 1982b) variables in the deciduous forested wetland and upland forest cover types. Variable averages were entered into Suitability Index Curves to obtain SI values. The appropriate SI values were used to obtain Winter Food and Cover/Reproduction Life Requisite values according to the calculations provided by the model. The final HSI value for each cover type equals the lowest Life Requisite value for that cover type.

Swamp Rabbit

Field data were collected for the Swamp Rabbit HSI Model (Allen 1985) variables in the deciduous forested wetland, herbaceous wetland, and shrub wetland cover types. Variable averages were entered into Suitability Index Curves to obtain SI values. Appropriate SI values were used to obtain Food/Cover Index (FCI) values, according to the calculations provided by the model for each cover type. The final HSI values for each cover type equal the FCI values multiplied by SIV6.

Racer

Field data were collected for the Racer HSI Model (author unknown 1980) variables in the shrubland cover type. Variable averages were entered into Suitability Index Curves to obtain Suitability Index (SI) values. SI1, SI2, and SI3 were used to obtain the Food Requisite value with the calculation provided by the model, while SI4 represents the Winter Cover Requisite. The final HSI value for each cover type equals the lowest Life Requisite value for that cover type.

Table 1. HSI Calculation Deciduous Forested Wetland Cover Type

Deciduous Forested Wetland		
Species: Swamp Rabbit, Downy Woodpecker, Wood Duck, Gray Squirrel, Green Heron, Fox Squirrel, Barred Owl		
FOX SQUIRREL		
Variable name/number		Value
% canopy closure of trees that produce hard mast >10 in dbh	V1	64.24
Distance to available grain	V2	1000.00
Average dbh of overstory trees	V3	12.71
% tree (>16.5 ft height) canopy closure	V4	89.47
% shrub (<16.5 ft height) crown cover	V5	41.12
		SI Value
	SI1	0.96
	SI2	0.10
	SI3	0.69
	SI4	0.63
	SI5	0.80
		<i>Winter Food Requisite = ((3*V1) + V2)/3</i>
		0.99
		<i>Cover/Reproduction Requisite = (V3 + V4 + V5)0.33</i>
		0.71
	HSI=	0.71

GRAY SQUIRREL		
Variable name/number		Value
% canopy closure of trees that produce hard mast >10 in dbh	V1	64.24
Diversity of tree species that produce hard mast	V2	2.82
% tree (>16.5 ft height) canopy closure	V3	89.47
Mean dbh of overstory trees that are >80% of height of tallest tree in stand	V4	12.88
% shrub (<16.5 ft height) crown cover	V5	41.12
		SI Value
	SI1	0.96
	SI2	0.80
	SI3	0.88
	SI4	0.79
	SI5	0.86
		<i>Winter Food Requisite = (V1 * V2)0.5</i>
		0.88
		<i>Cover/Reproduction Requisite = (V3 * V4)0.5 * V5</i>
		0.71
	HSI=	0.71

Deciduous Forested Wetland		
Species: Swamp Rabbit, Downy Woodpecker, Wood Duck, Gray Squirrel, Green Heron, Fox Squirrel, Barred Owl		
GREEN HERON		
Variable name/number		Value
Aquatic substrate composition in littoral zone	V1	1.00
% water area <10 in deep	V2	12.88
% emergent herbaceous canopy cover in littoral zone	V3	5.47
% water surface obstruction	V4	2.80
Water regime (average summer conditions)	V5	1.00
Water current (average summer conditions)	V6	1.00
Distance to deciduous forested or deciduous shrub wetland	V7	0.25
		SI Value
	SI1	1.00
	SI2	0.24
	SI3	0.22
	SI4	0.29
	SI5	0.30
	SI6	1.00
	SI7	1.00
<i>Food Requisite = (V1 * V2 * V3)0.33 + V4</i>		0.67
<i>Water Requisite = (V5 * V6)0.5</i>		0.55
<i>Reproductive Requisite = V7</i>		1.00
	HSI=	0.55

BARRED OWL		
Variable name/number		Value
# of tree >20" dbh/acre	V1	3.53
Average dbh of overstory trees	V2	12.71
% canopy cover of overstory trees	V3	85.24
		SI Value
	SI1	1.00
	SI2	0.51
	SI3	1.00
<i>SIR = (SIV1 * SIV2)0.5 * SIV3</i>	HSI=	0.72

DOWNY WOODPECKER		
Variable name/number		Value
Basal area (ft2 per acre)	V1	98.82
# of snags >6 in dbh/acre	V2	19.76
		SI Value
<i>Food Requisite</i>	SI1	0.86
<i>Reproduction Requisite</i>	SI2	1.00
	HSI=	0.86

Deciduous Forested Wetland		
Species: Swamp Rabbit, Downy Woodpecker, Wood Duck, Gray Squirrel, Green Heron, Fox Squirrel, Barred Owl		
SWAMP RABBIT		
Variable name/number		Value
% tree canopy closure	V1	89.47
% shrub crown closure	V2	41.12
% herbaceous canopy	V3/V4	29.82
Average height of herbaceous (feet)	V5	0.82
Water Regime	V6	3.76
		SI Value
	SI1	0.63
	SI2	0.84
	SI3/SI4	0.40
	SI5	0.01
	SI6	0.80
<i>Forest Food/Cover Index = SIV1</i>		0.63
HSI = FCI * SIV6	HSI=	0.51

WOOD DUCK		
Variable name/number		Value
# of potentially suitable tree cavities/acre*	V1	22.35
# of nest boxes/acre*	V2	0.00
Density of potential nest sites per acre	V3	4.02
% of water surface covered by pot. brood cover	V4	26.18
% of water surface covered by pot. winter cover	V5	26.18
		SI Value
<i>*V3=(0.18*V1) + (0.98*V2)</i>	SI3	0.80
	SI4	0.52
<i>See Wood Duck Multi-cover Type Worksheet</i>	SI5	0.52
	HSI=	0.68

Table 2. HSI Calculation Herbaceous Wetland Cover Type

Herbaceous Wetland		
Species: Swamp Rabbit, Wood Duck, Green Heron		
GREEN HERON		
Variable name/number		Value
Aquatic substrate composition in littoral zone (avg summer)	V1	1.00
% water area <10 in deep	V2	25.00
% emergent herbaceous canopy cover in littoral zone	V3	18.00
% water surface covered by logs, trees, or woody vegetation	V4	11.63
Water regime (average summer conditions)	V5	2.00
Water current (average summer conditions)	V6	2.00
Distance to deciduous forested or shrub wetland (miles)	V7	0.25
		SI Value
	SI1	1.00
	SI2	0.48
	SI3	0.51
	SI4	0.57
	SI5	0.90
	SI6	0.90
	SI7	1.00
	<i>Food Requisite = (V1 * V2 * V3)0.33 + V4</i>	1.19
	<i>Water Requisite = (V5 * V6)0.5</i>	0.90
	<i>Reproductive Requisite = V7</i>	1.00
	HSI=	0.90

WOOD DUCK		
Variable name/number		Value
# of potentially suitable tree cavities/acre*	V1	31.88
# of nest boxes/acre*	V2	0.00
Density of potential nest sites per acre	V3	5.74
% of water surface covered by potential brood cover	V4	42.50
% of water surface covered by potential winter cover	V5	39.50
		SI Value
	<i>*V3=(0.18*V1) + (0.98*V2)</i>	SI3 1.15
		SI4 0.85
		SI5 0.79
	<i>See Wood Duck Multi-cover Type Worksheet</i>	HSI= 0.68

Herbaceous Wetland		
Species: Swamp Rabbit, Wood Duck, Green Heron		
SWAMP RABBIT		
Variable name/number		Value
% tree canopy closure	V1	3.50
% shrub crown closure	V2	6.88
% herbaceous canopy cover	V3/V4	88.00
Average height of herbaceous (feet)	V5	3.53
Water Regime	V6	3.00
		SI Value
	SI1	0.14
	SI2	0.23
	SI3/SI4	1.00
	SI5	1.00
	SI6	0.50
<i>Herbaceous Wetland Food/Cover Index = (SIV4 * SIV5)0.5</i>		1.00
HSI = FCI * SIV6	HSI=	0.50

Table 3. HSI Calculation Shrub Wetland Cover Type

Shrub Wetland		
Species: Swamp Rabbit, Green Heron, Wood Duck		
SWAMP RABBIT		
Variable name/number		Value
% tree canopy closure	V1	21.00
% shrub crown cover	V2	62.50
% herbaceous canopy cover	V3/V4	71.50
Average height of herbaceous canopy (feet)	V5	1.13
Water Regime	V6	3.00
		SI Value
	SI1	0.84
	SI2	1.00
	SI3/SI4	0.95
	SI5	0.13
	SI6	0.50
<i>Shrub Wetland Food/Cover Indx = (SIV2+SIV3)/2</i>		0.98
HSI = FCI * SIV6	HSI =	0.49

WOOD DUCK		
Variable name/number		Value
<i># of potentially suitable tree cavities/acre*</i>	V1	20.00
<i># of nest boxes/acre*</i>	V2	0.00
Density of potential nest sites per acre	V3	3.60
% of water surface covered by potential brood cover	V4	45.00
% of water surface covered by potential winter cover	V5	40.00
		SI Value
<i>*V1=(0.18*V1) + (0.98*V2)</i>	SI3	0.72
	SI4	0.90
	SI5	0.80
<i>See Wood Duck Multi-cover Type Worksheet</i>	HSI =	0.68

Shrub Wetland		
Species: Swamp Rabbit, Green Heron, Wood Duck		
GREEN HERON		
Variable name/number		Value
Aquatic substrate composition in littoral zone	V1	1.00
% water area <10 in deep	V2	25.00
% emergent herbaceous canopy cover in littoral zone	V3	75.00
# water surface obstruction	V4	37.50
Water regime (average summer conditions)	V5	2.00
Water current (average summer conditions)	V6	2.00
Distance to deciduous forested or deciduous shrub wetland	V7	0.00
		SI Value
	SI1	1.00
	SI2	0.48
	SI3	2.83
	SI4	1.00
	SI5	0.90
	SI6	0.90
	SI7	1.00
<i>Food Requisite = (V1 * V2 * V3)0.33 + V4</i>		2.10
<i>Water Requisite = (V5 * V6)0.5</i>		0.90
<i>Reproductive Requisite = V7</i>		1.00
	HSI=	0.90

Table 4. HSI Calculation Upland Forest Cover Type

Cover Type: Upland Forest		
Species: Eastern Cottontail, Downy Woodpecker, Gray Squirrel, Fox Squirrel, Barred owl, Red-tailed Hawk		
FOX SQUIRREL		
Variable name/number		Value
% canopy closure of trees that produce hard mast >10 in dbh	V1	25.88
Distance to available grain	V2	1000.00
Average dbh of overstory trees	V3	11.38
% tree (>16.5 ft height) canopy closure	V4	78.63
% shrub (<16.5 ft height) crown cover	V5	30.38
		SI Value
	SI1	0.65
	SI2	0.10
	SI3	0.52
	SI4	0.77
	SI5	0.99
	<i>Winter Food Requisite = ((3*V1) + V2)/3</i>	0.68
	<i>Cover/Reproduction Requisite = (V3 + V4 + V5)0.33</i>	0.73
	HSI=	0.68

BARRED OWL		
Variable name/number		Value
% of trees >20" dbh/acre	V1	7.50
Average dbh of overstory trees	V2	11.38
% canopy cover of overstory trees	V3	77.50
		SI Value
	SI1	1.00
	SI2	0.43
	SI3	1.00
	<i>Reproduction Suitability Index (SIR) = (SIV1 * SIV2)0.5 * SIV3</i>	HSI= 0.65

RED-TAILED HAWK		
Variable name/number		Value
% canopy cover of overstory trees	V6	77.50
# of woody stems (>1 m tall) per acre	V7	439.38
# of tree >20" dbh/acre	V8	7.50
		SI Value
	SI6	0.47
	SI7	0.54
	SI8	0.80
	<i>See Red-tailed Hawk Multi-cover Type Worksheet</i>	HSI= 0.84

Cover Type: Upland Forest		
Species: Eastern Cottontail, Downy Woodpecker, Gray Squirrel, Fox Squirrel, Barred owl, Red-tailed Hawk		
GRAY SQUIRREL		
Variable name/number		Value
% canopy closure of trees that produce hard mast >10 in dbh	V1	25.88
Diversity of tree species that produce hard mast	V2	1.63
% tree (>16.5 ft height) canopy closure	V3	78.63
Mean dbh of overstory trees of those trees that are >80% of the height of the tallest tree in the stand	V4	11.38
% shrub (<16.5 ft height) crown cover	V5	30.38
		SI Value
	SI1	0.65
	SI2	0.50
	SI3	0.97
	SI4	0.64
	SI5	0.99
		<i>Winter Food Requisite = (V1 * V2)0.5</i>
		0.57
		<i>Cover/Reproduction Requisite = (V3 * V4)0.5 * V5</i>
		0.78
	HSI=	0.57

DOWNY WOODPECKER		
Variable name/number		Value
Basal area (ft ² per acre)	V1	80.00
% of snags >6 in dbh/acre	V2	12.75
		SI Value
		<i>Food Requisite</i>
	SI1	1.00
		<i>Reproduction Requisite</i>
	SI2	1.00
	HSI=	1.00

EASTERN COTTONTAIL		
Variable name/number		Value
% shrub (<16.5 ft height) crown cover	V1	30.38
% tree (>16.5 ft height) canopy closure	V2	78.63
% canopy closure of persistent herbaceous vegetation	V3	73.75
		SI Value
	SI1	1.00
	SI2	0.54
	SI3	0.44
		<i>Winter Cover/Food Index = max value of ((4*(SIV1)+SIV2)/5) + SIV3</i>
		1.35
	<i>See Eastern Cottontail Multi-cover Type Worksheet</i>	HSI= 0.73

Table 5. HSI Calculation Grassland Cover Type

Cover Type: Grassland		
Species: Racer, Eastern Cottontail, Eastern Meadowlark, Red-tailed Hawk		
EASTERN MEADOWLARK		
Variable name/number		Value
% herbaceous canopy cover	V1	98.33
Proportion of herbaceous canopy cover that is grass	V2	50.00
Average height of herbaceous canopy (spring conditions) (centimeters)	V3	20.74
Distance to perch site (meters)	V4	30.00
% shrub (<16.5 ft height) crown cover	V5	0.00
		SI Value
	SI1	1.00
	SI2	0.50
	SI3	1.00
	SI4	1.00
	SI5	1.00
<i>Food/Reproduction Requisite = (V1 * V2 * V3 * V4)0.5 * V5</i>	HSI=	0.71

EASTERN COTTONTAIL		
Variable name/number		Value
% shrub (<16.5 ft height) crown cover	V1	0.00
% tree (>16.5 ft height) canopy closure	V2	0.00
% canopy closure of persistent herbaceous vegetation	V3	71.67
Diversity Index; ratio of cover type edge to total area	V4	1.00
		SI Value
	SI1	0.00
	SI2	0.00
	SI3	0.43
	SI4	0.67
<i>Winter Cover/Food Index = max value of ((4*(SIV1)+SIV2)/5) + SIV3</i>		0.43
<i>See Eastern Cottontail Multi-cover Type Worksheet</i>	HSI=	0.73

RACER		
Variable name/number		Value
% herbaceous canopy cover	V1	98.33
Average height of herbaceous canopy (feet)	V2	0.68
Distance to shrubby edges or shrub thickets (feet)	V3	83.33
# of refuge sites per acre	V4	0.00
		SI Value
	SI1	1.00
	SI2	0.25
	SI3	1.00
	SI4	-0.00
<i>Food Requisite = (2(V1 * V2)0.5 + V3)/2</i>		1.00
<i>Winter Cover Requisite (SI4)</i>		-0.00
	HSI=	-0.00

RED-TAILED HAWK		
Variable name/number		Value
% herbaceous canopy cover	V1	98.33
% herbaceous canopy 6-24 in tall	V2	10.00
# of tree >20" dbh/acre	V8	0.00
		SI Value
	SI1	1.00
	SI2	0.32
	SI8	0.30
<i>See Red-tailed Hawk Multi-cover Type Worksheet</i>	HSI=	0.84

Table 6. HSI Calculation Riverine Cover Type

WOOD DUCK		
Variable name	Variable Number	Value
# of potentially suitable tree cavities/acre*	V1	28.86
# of nest boxes/acre*	V2	0.00
Density of potential nest sites per acre	V3	4.11
% of the water surface covered by potential brood cover	V4	28.57
% of water surface covered by potential winter cover	V5	25.00
		SI Value
<i>*V3 = (0.18*V1)+(0.95*V2)</i>	SI3	0.82
	SI4	0.57
	SI5	0.50
<i>See Wood Duck Multi-cover Type Worksheet</i>	HSI=	0.68

BELTED KINGFISHER		
Variable name/number		Value
% of shoreline subject to severe wave action	V1	0.00
Water turbidity*	V2	3.00
% water surface obstruction	V3	16.86
% of water that is < 24" in depth	V4	42.86
% riffles	V5	0.00
Availability of perch sites*	V6	5.00
Distance to nearest suitable soil bank from 1-km sections of lentic shore	V7	0.00
		SI Value
<i>*1980 Review Copy</i>	SI1	1.00
	SI2	0.30
	SI3	0.83
	SI4	0.57
	SI5	0.20
	SI6	1.00
	SI7	1.00
<i>Water Requisite Value (Eq.1): SIW=(SIV2 *SIV4)1/2 * SIV3</i>		0.34
<i>Cover Requisite Value (SIV6)</i>		1.00
<i>Reproduction Requisite Value (SIV7)</i>		1.00
	HSI=	0.34

GREEN HERON		
Variable name/number		Value
Aquatic substrate composition in littoral zone	V1	1.00
% water area <10 in deep	V2	27.67
% emergent herbaceous canopy cover in littoral zone	V3	2.57
# water surface obstruction	V4	16.86
Water regime (average summer conditions)	V5	3.00
Water current (average summer conditions)	V6	2.00
Distance to deciduous forested or deciduous shrub wetland	V7	0.25
		SI Value
	SI1	1.00
	SI2	0.53
	SI3	0.16
	SI4	0.74
	SI5	1.00
	SI6	0.90
	SI7	1.00
	<i>Food Requisite = (V1 * V2 * V3)0.33 + V4</i>	1.18
	<i>Water Requisite = (V5 * V6)0.5</i>	0.95
	<i>Reproductive Requisite = V7</i>	1.00
	HSI=	0.95

Table 7. HSI Calculation Shrubland Cover Type

Cover Type: Shrubland		
Species: Eastern Cottontail, Red-tailed Hawk, Racer		
EASTERN COTTONTAIL		
Variable name/number		Value
% shrub (<16.5 ft height) crown closure	V1	68.33
% tree (>16.5 ft height) canopy closure	V2	0.33
% canopy closure of persistent herbaceous vegetation	V3	68.25
		SI Value
	SI1	0.85
	SI2	0.01
	SI3	0.41
<i>Winter Cover/Food Index = max value of ((4*(SIV1)+SIV2)/5) + SIV3</i>		1.09
<i>See Eastern Cottontail Multi-cover Type Worksheet</i>	HSI=	0.73

RACER		
Variable name/number		Value
% herbaceous canopy cover	V1	91.00
Average height of herbaceous canopy (feet)	V2	0.86
Distance to shrubby edges or shrub thickets (feet)	V3	23.33
# of refuge sites per acre	V4	83.33
		SI Value
	SI1	1.00
	SI2	0.33
	SI3	1.00
	SI4	1.00
<i>Food Requisite = (2(V1 * V2)0.5 + V3)/2</i>		1.08
<i>Winter Cover Requisite (SI4)</i>		1.00
	HSI=	1.00

RED-TAILED HAWK		
Variable name/number		Value
% herbaceous canopy cover	V1	91.00
% herbaceous canopy 6-24" tall	V2	80.00
% shrub (<16.5 ft height) crown closure	V3	68.33
# trees >20" dbh	V8	0.00
		SI Value
	SI1	1.00
	SI2	1.00
	SI3	0.96
	SI8	0.30
<i>See Red-tailed Hawk Multi-cover Type Worksheet</i>	HSI=	0.84

Table 8. Wood Duck Multi-cover Type Worksheet

% Relative Areas of Wood Duck Cover Types at Lake Eastex					
Cover Type	Bottomland Hardwood	Herbaceous Wetland	Shrub Wetland	Riverine	Totals
Area (acres)	3652.6	1349.5	132.8	297.0	5431.9
Relative Area	67.24	24.84	2.44	5.47	100.00

% Useable Relative Areas (adjusted by Life Requisite Values)			
BH	Nesting (SI3*)	Brooding (SI4)	Winter (SI5)
Average SI	0.8	0.6	0.5
Adjusted Area	54.11	40.35	1826.3
S. Wetland			
Average SI	1.0	0.9	0.8
Adjusted Area	2.44	2.20	106.24
H. Wetland			
Average SI	1.0	0.9	0.8
Adjusted Area	24.84	22.36	1066.11
Riverine			
Average SI	0.7	0.6	0.5
Adjusted Area	4.08	3.28	148.50

% Area in Optimal Condition	
Nesting	85.5
Brooding	68.2
<i>sums of adjusted areas</i>	

Overall Wood Duck Life Requisite Values	
Nesting (V7)	1.00
Brood Rearing (V8)	0.68
Winter Habitat*	0.58
Breeding Suitability Value	0.68
Year-round HSI Value	0.68
<i>*adjusted by area, sum divided by total area</i>	

Table 9. Eastern Cottontail Multi-cover Type Worksheet

Eastern Cottontail Winter Food/Cover Index (WCFI) Calculations by Cover Type				
Suitability Index Averages				
Cover Type	SI 1	SI 2	SI 3	WCFI
Grassland	0.0	0.0	0.4	0.43
Upland Forest	1.0	0.5	0.4	1.00
Shrubland	0.9	0.0	0.5	1.00

Winter Cover/Food Index = maximum value of $((4(SIV1)+SIV2)/5) + SIV3$ or 1.0

Grassland WCFI: $((4(0.0)+0.0)/5) + 0.43 = 0.43$*

Upland forest WCFI: $((4(1.0)+0.54)/5) + 0.44 = 1.35$*

Shrubland WCFI: $((4(0.85)+0.01)/5) + 0.41 = 1.09$*

Adjusted Relative Area Calculations for Eastern Cottontail by Cover Type				
Cover Type	Area (acres)	Relative Area	WCFI	Adjusted Relative Area*
Grassland	2188.9	0.48	0.43	0.21
Upland Forest	2181.6	0.48	1.00	0.48
Shrubland	189.7	0.04	1.00	0.04
Totals	4560.2	1.00	Final HSI Value** = 0.73	

**product of Relative Area and WCFI*

***Weighted WCFI Value (sum of Adjusted Relative Areas)*

Table 10. Red-tailed Hawk Multi-cover Type Worksheet

Life Requisites for Red-Tailed Hawk (RTHA) by Cover Type						
Cover Type	Variables					
	V1	V2	V3	V6	V7	V8
Grassland	F	F	~	~	~	C/R
Upland Forest	~	~	~	F	F	C/R
Shrubland	F	F	F	~	~	C/R
<i>F=Food Value</i>						
<i>C/R=Cover/Reproductive Value</i>						

Relative Areas of RTHA Cover Types at Lake Eastex				
Cover Type	G	UF	S	Totals
Area (acres)	2188.9	2181.6	189.7	4560.2
Relative Area	0.48	0.48	0.04	1.00

Life Requisite Support by Cover Type				<i>(adjusted by Cover Type Relative Area)</i>	
Grassland	Food		Cover/Reproduction		
	SI1	SI2	SI8	Food Requisite Aggregation Functions	
Average	1.0	0.3	0.3		
Adjusted Ave.	0.48	0.14	0.14		
<i>Product = 0.26</i>				<i>(SI1 x SI2)0.5</i>	
Upland Forest	SI6	SI7	SI8	Food Requisite Aggregation Functions	
Average	0.5	0.5	0.8		
Adjusted Ave.	0.24	0.24	0.38		
<i>Product = 0.24</i>				<i>(SI6 + SI7)/2</i>	
Shrubland	SI1	SI2	SI3	SI8	Food Requisite Aggregation Functions
Average	1.0	1.0	1.0	0.3	
Adjusted Ave.	0.04	0.04	0.04	0.01	
<i>Product = 0.08</i>				<i>(SI1 x SI2)0.5 + SI3</i>	

Total RTHA Life Requisite Support	
Food	C/R
0.59	0.54
<i>sums</i>	

Actual RTHA Life Requisite Value	
Food	C/R
0.84	5.39
<i>adjusted by Optimal % Estimates</i>	

RTHA HSI
0.84

APPENDIX 5 – FNI GEOTECHNICAL INVESTIGATION

LAKE EASTEX DAM
PRELIMINARY GEOTECHNICAL INVESTIGATION
REPORT

Prepared for

Angelina and Neches River Authority

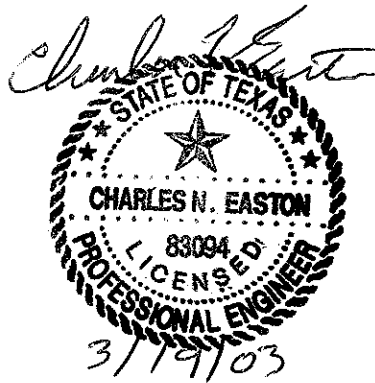

Prepared by



ANR01289

APPENDIX 5 – GEOTECHNICAL INVESTIGATION

TABLE OF CONTENTS

	PAGE
1.0 INTRODUCTION	1
1.1 Project Description.....	1
1.2 Authorization and Scope	1
2.0 FIELD AND LABORATORY INVESTIGATIONS.....	3
2.1 Field Investigation	3
2.2 Laboratory Investigation	5
3.0 GEOLOGIC AND SUBSURFACE CONDITIONS.....	6
3.1 Site Description	6
3.2 Geology	6
3.3 Subsurface Conditions	8
3.3.1 Dam Foundation.....	8
3.3.2 Borrow Areas.....	8
3.4 Groundwater	9
4.0 ANALYSIS AND DISCUSSION.....	10
4.1 Embankment Design.....	10
4.1.1 Embankment Materials.....	10
4.1.2 Embankment Foundation.....	11
4.1.3 Embankment Zones.....	11
4.1.4 Embankment Slopes.....	12
4.1.5 Stabilizing Fills	12
4.1.6 Foundation Preparation	13
4.1.7 Underseepage Control	13
4.1.8 Drainage	13
4.1.9 Embankment Settlement.....	15
4.2 Structure Foundations	15
4.3 Slope Protection.....	15
4.3.1 Downstream Slope.....	15
4.3.2 Upstream Slope.....	16
5.0 CONCLUSIONS.....	17
6.0 LIMITATIONS	18

TABLES	PAGE
Table 1 – Boring Coordinates and Elevations	4

FIGURES

- Figure 1 – Geologic Map
- Figure 2 – Boring Location Plan – USGS Topo Base Map
- Figure 3 – Boring Location Plan – Aerial Photo August 2001
- Figure 4 – Surface Soil Types
- Figure 5 – Geologic Profile Along proposed Dam
- Figure 6 – Typical Dam Section

APPENDICES

- APPENDIX A – Figures
- APPENDIX B – Boring Logs
- APPENDIX C – Laboratory Test Results

1.0 INTRODUCTION

1.1 Project Description

The Angelina and Neches River Authority (ANRA) plans to develop a water supply reservoir on Mud Creek, a tributary of the Angelina River. The reservoir, Lake Eastex, will be created by a dam located in Cherokee County about nine miles east-southeast of Jacksonville, Texas. The reservoir will have a surface area of about 10,000 acres and a storage capacity of about 195,000 acre-feet with a normal pool level at elevation 315 feet msl.

The dam for Lake Eastex will be an earthen structure about 6,600 feet long. The top of dam elevation will be 339 feet msl. The maximum height will be about 77 feet above the streambed. Across the floodplain, a distance of about 5,100 feet, the height will generally be between 64 and 69 feet. The dam is expected to be a zoned embankment with a clay core and random fill shells. A slurry trench cutoff extending to a low permeability clay layer is preferred for underseepage control. A layer of soil cement is planned for wave protection on the upstream slope. A drainage blanket beneath the downstream slope and a chimney drain will be considered.

The outlet works are expected to consist of an intake tower near the upstream toe of the dam, a single or double conduit through or below the base of the embankment, control valves, and a stilling basin. It will likely be constructed near the east edge of the floodplain.

The service spillway will be an uncontrolled overflow structure 200 feet wide constructed in a cut through the left (east) abutment. It will have vertical reinforced concrete sidewalls and a concrete ogee section. Approach and outlet channels will be excavated through the abutment with sloping sides and protected with a combination of soil-cement and grass.

The emergency spillway will be an unlined earth channel 1,100 feet wide excavated through the right abutment. The side slopes may be protected with soil cement. An eight-foot deep concrete cutoff wall at the crest is planned for a control section.

1.2 Authorization and Scope

A water rights permit for Lake Eastex was obtained in 1985. The feasibility study supporting the water rights permit application was prepared by Lockwood, Andrews & Newnam, Inc. in 1984.

This report presents the findings of a preliminary geotechnical investigation performed to provide information for the preliminary design of the dam. This work was authorized by the Engineering Services Agreement dated June 11, 2001, between the ANRA and Freese and Nichols, Inc.

The feasibility study completed in 1984 included a preliminary geotechnical investigation by Rone Engineers, Dallas, Texas. That investigation included three borings numbered B-1, B-2, and B-3, and laboratory testing of index properties. We have included graphical logs of those borings, with laboratory test results, on the dam profile presented in Figure 5. The individual boring logs are reproduced in Appendix B.

Our investigation included six additional borings along the proposed dam alignment, eight borings in potential borrow areas within the proposed reservoir area, and laboratory testing to determine classification and index properties of selected soil samples. Some of the available literature reviewed included geologic maps, the Cherokee County Soil Survey Report, and a report of salt domes in the general area. Additional investigations and analyses will be needed for final design.

The data obtained in the field and laboratory investigations are presented in this report with a discussion relating the observed geotechnical conditions to preliminary dam design issues.

FIELD AND LABORATORY INVESTIGATIONS

2.1 Field Investigation

A site visit was made by Mr. Charles Easton and Mr. Larry Clendenen on November 16, 2001, to stake the locations of Borings B-101 through B-105.

Six borings numbered B-101 through B-106 were drilled approximately along the proposed dam centerline, and eight borings numbered C-1 through C-4 and S-1 through S-4 were drilled in potential borrow areas during the periods November 19-26, 2001 and July 24-26, 2002. The boring locations are shown on Figures 2 and 3, and the coordinates and surface elevations are listed in Table 1. The borings were located and staked in the field using a hand-held GPS receiver and adjusted for local conditions. Locations of Boring B-102 through B-105 were also determined using a backpack GPS receiver and are considered accurate within about two feet. The locations of the other borings are considered accurate within about thirty feet. The ground surface elevations at Borings B-101 through B-106 were estimated from a topographic strip map presented in the 1983 geotechnical report by Rone Engineers. They are considered accurate within about two feet. The ground surface elevations at the other boring locations were estimated from the 1:24,000-scale USGS topographic map: they are considered accurate within about ten feet.

The borings were drilled using a truck-mounted Mobile B-61 drilling rig and a track-mounted Diedrich D-50 drilling rig. Borings B-101 through B-106 were drilled with augers until groundwater was encountered, then continued by rotary wash boring using plain water or bentonitic drilling fluid as necessary. Samples were obtained generally at 5-foot intervals by pushing 3-inch diameter thin-walled tubes or by driving a standard 2-inch O.D. split-spoon sampler and running the Standard Penetration Test. The bore holes were filled with grout. Borings C-1 through C-4 and S-1 through S-4 were drilled with continuous flight augers, and disturbed samples were taken from the auger cuttings. The bore holes were backfilled with soil.

Hand-held penetrometer tests were run in the field on cohesive samples, and the results are shown on the boring logs. Where penetrometer values are shown for split-spoon samples, the results were probably affected significantly by the disturbance caused by sampling.

Table 3-1. Boring Locations

Boring Number	Elevation (feet msl)	UTM Coordinates, meters	
		Easting	Northing
B-1	320	298359.6	3536722.3
B-2	271	297895.7	3536369.7
B-3	325	296594.6	3535198.0
B-101	288	296768.5	3535353.3
B-102	270	296987.8	3535566.8
B-103	273	297218.0	3535790.6
B-104	270	297581.7	3536144.9
B-105	301	298071.8	3536589.3
B-106	320	296658.7	3535318.8
C-1	305	296358.9	3536425.2
C-2	310	296045.7	3537123.6
C-3	313	295590.8	3537513.2
C-4	272	297162.2	3537341.2
S-1	302	297090.1	3539278.2
S-2	287	297130.8	3538885.2
S-3	283	296940.6	3538370.5
S-4	283	296704.9	3535866.2

Notes:

- Borings B-1, B-2 & B-3 (also called CB-1, CB-2 & CB-3) were drilled by Rone Engineers in 1983. Elevations and locations are taken from their report.*
- Locations of the other borings were determined by GPS receiver and are considered accurate within about 30 feet. Elevations were estimated from 10-foot contours of the USGS 7.5-minute quadrangle or from a strip contour plan in Rone Engineers' 1983 report. Actual elevations may vary several feet from those shown.*

Indications of free subsurface water observed during drilling, such as water entry or the first samples that appeared saturated, were noted on the boring logs. Borings B-101 through B-104 and B-106 were partially bailed after drilling to reduce the effects of adding drilling fluid, and the water levels were measured 30 minutes to two days later, as noted on the logs. The water levels in Borings B-105, C-1 through C-4, and S-1 through S-4 were measured immediately after completion.

The individual boring logs are presented in Appendix B. Graphical boring logs with selected laboratory test results are shown on the dam profile in Figure 5.

2.2 Laboratory Investigation

Laboratory tests were run by E TTL on samples selected by their engineer to determine index and classification properties of representative soil samples. The test results are summarized on the boring logs in Appendix B. Several samples of clay from Borings B-106 and C-1 through C-4 were tested for dispersive behavior using the crumb test. The results are presented in Appendix C.

3.0 GEOLOGIC AND SUBSURFACE CONDITIONS

3.1 Site Description

Mud Creek has a broad, flat valley flanked by low hills. The maximum local relief is about 200 feet. The valley floor at the dam site is about elevation 270 feet msl. Keys Creek joins Mud Creek from the west about 1-1/4 miles downstream from the dam site. A narrow ridge with its crest at about elevation 335 feet msl separates the two creek valleys at the right (west) abutment.

Mud Creek has a low gradient and multiple meandering channels. The USGS topographic map shows two channels at the dam site and marshy areas between the channels and the edges of the valley. A 1994 aerial photo showed the left (east) abutment and most of the valley to be heavily wooded. In recent years the dam site has been logged and cleared, and the channels have been straightened. The central part of the valley is a plowed field. The rest of the dam site is pasture with scattered trees. The marshy areas remain. In November 2001 there was general seepage from the hillside below Boring B-101. The water is collected by several small drainage ditches and directed to a pond. Springs were seen on the hillside near Boring B-105.

The potential borrow areas around Borings C-101 through C-104 and S-101 through S-104 are mostly open pasture with scattered trees.

3.2 Geology

Part of the Palestine Sheet of the Geologic Atlas of Texas is reproduced in Figure 1. The map indicates that the bedrock formation exposed in the abutments of the dam site is the Queen City Sand of Eocene age. The Queen City Sand is described as "*Quartz sand, fine grained, brownish gray; thin irregular interbeds of light brown to light gray clay; a few glauconite lentils; clay-ironstone beds and concretions common. Sand weathers pale red to grayish orange, clay weathers brownish gray to very light gray, resulting in a distinctive intermixing of colors characteristic of the formation. Thickness 325 feet in Southwestern Anderson County, feathers out eastward in western San Augustine County.*" Local experience indicates that the Queen City Sand formation can vary considerably and individual beds may not be continuous across the spacing of the borings drilled for our preliminary investigation.

The Queen City Sand is underlain by the Reklaw Formation, the upper part of which is mostly carbonaceous clay and silt. It is possible that the clays encountered in the lower part of the borings are part of the Reklaw Formation. Mr. Les Jeske, Senior Geologist with ETTL, has indicated his opinion that the clays are part of the Queen City Sand.

The regional dip of the Eocene formations is generally southeast at one to two percent. There was not sufficient correlation of distinct horizons between the borings to determine the general dip of the beds at the dam site.

Alluvium is mapped in the floodplain of Mud Creek. A large Quaternary terrace is shown along the west side of the valley upstream from the dam site, however, the Cherokee County Soil Survey and borings made for this investigation indicate that this is actually not an alluvial terrace, but an exposure of clays of the Queen City Sand formation at an elevation intermediate between the floodplain and the uplands.

Faults roughly paralleling the dam alignment are shown mapped three quarters of a mile downstream and two miles upstream from the dam site. These faults are part of the Balcones Fault System. The downstream fault reportedly dips to the northwest and is downthrown to the northwest, whereas the upstream fault is downthrown to the southeast, so the dam site is in a graben. The faults in the region are generally considered to be inactive.

Salt domes occur within Jackson County, and a salt pillow is mapped immediately southeast of the dam site. The top of the salt pillow is about 14,000 feet below the ground surface. It is considered possible but unlikely that the salt deformation has affected the local dip of the shallow formations.

The Cherokee County Soil Survey prepared by the U.S. Department of Agriculture shows numerous types of surface soils within the proposed dam and reservoir area. We prepared a simplified map to aid exploration for potential borrow materials by grouping the soils into four general classifications:

- Sandy terrace and floodplain alluvium (loamy fine sand),
- Sandy and clayey alluvium (fine sandy loam and sandy clay loam),
- Sandy and clayey marine and alluvial sediments (sandy clay loam, sandy clay, and clay loam), and
- Marine clay, sandy clay, or shale (clay).

The map is shown in Figure 4. The borings drilled in potential borrow areas generally confirmed the mapped conditions.

3.3 Subsurface Conditions

3.3.1 Dam Foundation

The dam profile on Figure 5 shows the graphical logs of the borings along the proposed dam centerline. The borings in the valley show 18 to 28 feet of alluvium underlain by the clays and sands of the Queen City Sand formation. In the abutments the thickness of the alluvium is difficult to determine, but the combined thickness of alluvium and weathered older materials is probably less than 35 feet. The alluvium appears to be primarily firm to very stiff lean clay and loose to medium dense silty and clayey fine-grained sand. A few feet of fat clay was encountered at Borings B-3, B-101, and B-105. A few feet of gravelly sand or gravel was encountered in Borings B-101 and CB-2.

The Queen City Sand materials beneath the alluvium include very stiff to hard lean clays and fat clays as well as very dense fine-grained sands. The clays predominate in the valley, where all the borings encountered at least 30 feet of clay. Sand was penetrated a few feet at the bottom of Borings B-101, B-2, and B-1, below the clay.

The conditions at the west abutment as shown by Borings B-3 and B-106 are significantly different than at the other borings. Boring B-106 shows mostly sand from 43 to 88 feet followed by 12 feet of lean clay. Boring B-3 showed sand from 22 feet to the bottom of the boring at 90 feet; it was the only boring that did not locate an underlying layer of clay. The thick sand deposits in the west abutment are thought to have been placed after the clays were eroded by a stream in Eocene times.

3.3.2 Borrow Areas

Borings C-1 through C-3 show mostly stiff to very stiff lean and fat clays believed to be part of the Eocene formations. Boring C-4 encountered silty sand and stiff lean sandy clay alluvium of the present floodplain.

Several clay samples exhibited slight to moderate dispersivity in a crumb test. Additional testing will be needed to further evaluate whether the proposed borrow materials are sufficiently dispersive to limit their use in construction.

Borings S-1 through S-3 encountered mostly silty fine-grained sand. These deposits may be recent alluvium deposited as alluvial fans, or they may be part of a Quaternary

terrace deposited by Mud Creek when it flowed at a higher base level.

Boring S-4 shows a combination of silt, sandy lean clay, and silty sand that may be Recent or Quaternary alluvium.

3.4 Groundwater

The deep borings (B-101 through B-106) were drilled with water. Upon completion, the water level was lowered by bailing. The water level was measured a short time after bailing and again twenty minutes to two days later. In the 1983 investigation an observation well was installed to a depth of 87 feet in Boring B-3, and one was set to a depth of 58 feet in Boring B-2. We have no record of the details of construction. The water level was reportedly 10 feet below the ground surface at B-3 and six feet below the ground surface in B-2 one week after completion.

The observations indicate that the water table in the floodplain was 3 to 8 feet below the ground surface when the borings were drilled. It probably fluctuates a few feet with seasonal variations of rainfall and the creek level. Water levels at the locations of the proposed abutments were indicated 10 to 38 feet below the ground surface. It is likely that both perched water conditions and artesian conditions exist in different sandy layers separated by clay layers in the abutments. The observed springs and swamps on the lower part of the abutments clearly show groundwater movement from the hills towards the valley. The source of this water is probably infiltration of rainfall in the nearby uplands.

The shallow borings in the proposed borrow areas were drilled with augers. The depth at which seepage was observed during drilling and the water level in the boring upon completion are noted on the logs. Boring C-3 was dry. The other borings indicated water levels ranging from 3 to 17 feet below the surface.

4.0 ANALYSIS AND DISCUSSION

4.1 Embankment Design

Design of the embankment must consider safety, maintenance, and construction cost. Safety requires careful control of seepage through the embankment and foundation, adequate stability of the slopes, and protection against excessive erosion. Maintenance is enhanced by slopes that can be easily mowed, durable wave protection, limited settlement of the embankment and appurtenant structures, and minimization of wet ground conditions. Economical construction requires efficient use of nearby native materials, steeper slopes to minimize quantities, minimal foundation preparation, and simplicity that allows the builder freedom in obtaining and utilizing materials as well as sequencing his operations. Design involves balancing these often-conflicting requirements.

Preliminary selection of a typical dam cross section was based on recommendations presented in "Design of Small Dams" (DSOD), Third Edition, by the United States Bureau of Reclamation. The recommendations in the above publication are based on general soil classifications rather than site-specific soil properties determined by laboratory testing.

In general, the types of available fill materials govern the selection of the dam slopes and the shape of the various embankment zones. The foundation soil conditions govern the selection of the seepage control features and the slope of any stabilizing fills, or berms.

Additional borings, field tests, laboratory tests, and analyses will be required in the final design phase to select design criteria and finalize selection of the dam section.

4.1.1 Embankment Materials

4.1.1.1 Material From Required Excavations

The dam will require roughly 3.6 million cubic yards of embankment material. Excavation for the cutoff trench, service spillway, and emergency spillway is expected to produce about 2.2 million cubic yards of material. The materials that must be excavated include silty and clayey sands, lean clays, some relatively clean sands, and a relatively small amount of fat clay. The soils from the emergency spillway excavation will provide most of the excavated quantity, and are expected to be mostly sandy lean clays and clayey sands. Excluding the fat clays would allow the excavated materials to be used in "random fill" zones with design based on the properties of lean clay.

4.1.1.2 Borrow Materials

The borrow area borings indicate that ten-foot deep borrow pits could produce nearly four million cubic yards of lean and fat marine clays in the vicinity of Borings C-1 through C-3 and nearly three million cubic yards of silty fine-grained sands in the vicinity of Borings S-1 through S-3. Both areas are favorably located within the reservoir area but well above the floodplain. Mixed silty sands and lean clays were found at Borings C-4 and S-4, which are probably representative of the abundant floodplain and lower terrace soils.

4.1.2 Embankment Foundation

The foundation includes extensive areas underlain by permeable sandy soils that can carry significant quantities of seepage beneath the dam. The borings indicate that these zones are underlain by thick clay deposits that appear to be continuous, except at the west abutment, where the sandy soils extend to nearly 100 feet below the surface of the uplands.

The upper foundation soils include some areas with firm to stiff alluvial lean clays and loose silty and clayey sands. These weaker soils are generally limited to the upper 20 feet or less of the profile. The deeper soils are generally very dense or hard.

4.1.3 Embankment Zones

An unzoned section constructed using the convenient materials would likely contain some permeable sandy zones that might lead to seepage exiting the downstream embankment slope, which can cause trouble with slope stability and maintenance. The fat clays, available in large quantities, can be nearly impermeable, but are relatively difficult to process. A zoned section with a clay core and mixed soil shells that make efficient use of the excavated materials will likely be more economical and perform better than a homogeneous section.

A clay core with 1 horizontal to 1 vertical slopes is recommended. A narrower core might require an expensive downstream chimney drain to lower the phreatic surface and control piping through possible cracks. A wider core would require substituting borrow material for available excavated soil.

The shells can be constructed using the excavated materials with the fat clay excluded to avoid the flatter slopes that are required for fat clays. It would be desirable to place the cleaner sands adjacent to the downstream boundary of the clay core to facilitate internal drainage.

The stabilizing fills can be built with random available materials, avoiding any soils that may not support vegetation at the downstream face.

Preliminary tests indicated that some of the clays from the borrow areas are slightly to moderately dispersive, that is, they may tend to disperse into a colloidal suspension when exposed to moving water. Dispersive clays can be problematic in earth dams. Dispersive clays on the outer surface of the embankment can be eroded into jug-shaped cavities several feet deep. Where cracks can develop, dispersive clays in the interior of the dam can lead to subsurface erosion called piping. Additional sampling and testing will be needed during final design to determine whether the dispersive potential of any of the borrow soils is sufficient to require restricting their use. Although some restrictions may be necessary, it is unlikely that much difficulty will be encountered in locating sufficient suitable clay for the dam.

4.1.4 Embankment Slopes

Assuming an embankment with a clay core and random shells of lean clay or sandy soils, DSOD guidelines call for a downstream slope of 2.5 horizontal to 1 vertical or flatter. Experience has shown that 3 horizontal to 1 vertical downstream slopes are easier and safer to maintain.

The guidelines recommend an upstream slope of 3.5 horizontal to 1 vertical if sudden drawdown may occur or 3 horizontal to 1 vertical if not. The reservoir will be subject to sudden drawdown only from the maximum water level to the normal pool level after large floods. Penetration of water into the embankment during the flood will be limited. Use of a 3 horizontal to 1 vertical slope is reasonable at this stage of design.

4.1.5 Stabilizing Fills

Weak foundation soils can be the controlling factor for slope stability in higher dams. Given this condition, DOSD guidelines recommend stabilizing fills with flatter slopes extending one-half the height of the embankment. The slopes of the stabilizing fills are a function of the average consistency and type of soil within a depth equal to the height of the dam.

Based on the limited thickness of the weak fine-grained soils, slopes of 4 horizontal to 1 vertical to 6 horizontal to 1 vertical, depending on the location, appear appropriate. The exceptions occur at Borings B-101 and B-105, where stiff fat clays occur at shallow depth. The guidelines indicate slopes of about 10 horizontal to 1 vertical where fat clays occur. It

would be preferable to remove the shallow deposits of fat clay and replace them with sandy soils to allow use of the steeper slopes.

The guidelines indicate slopes of 10 horizontal to 1 vertical where hard fat clays occur, as they do below depths of about 20 to 30 feet at most locations. Because the deep fat clays are dense, old deposits, we believe this recommendation to be overly conservative. However, detailed laboratory testing and stability analyses will be required during final design to confirm this judgment.

4.1.6 Foundation Preparation

With a slurry trench cutoff to control underseepage, foundation preparation can be limited to clearing, grubbing and stripping of topsoil, plus excavation of a minimal cutoff trench intended primarily to permit detection of shallow deposits of sand, organics, or other objectionable materials. The strippings can largely be reused as topsoil on the downstream dam slope. Because much of the site was recently cleared of heavy timber, considerable grubbing may be required to remove tree stumps and roots. Swampy areas will pose some construction difficulties, and existing and abandoned creek channels will need to be cleaned of weak and organic materials.

4.1.7 Underseepage Control

Except at the west abutment, marine clays were encountered at depths of 20 to 30 feet. A slurry trench cutoff beneath the dam can provide effective and reasonably economical seepage control. The trench should extend through the sandy soils and about 5 feet into the marine clay. Additional borings will be needed to confirm that the marine clays are continuous. In the west abutment, the surface of the marine clay appears to be about 40 feet lower, and the cutoff would need to be as much as 100 feet deep. Additional investigation in the west abutment will be needed to define the potential seepage routes and determine whether a deep slurry trench extending into the abutment or an impervious upstream clay blanket is the preferred approach at that location.

4.1.8 Drainage

None of the observed on-site sands are clean enough to serve as drainage materials. The fine silty sand found at Borings S-1 through S-3 could conceivably be washed to create a fine filter sand that could transmit small flows. Concrete sand can probably be used as a

filter against most of the on-site soils. We understand that concrete sand and pea gravel are produced at Malakoff, about 70 miles northwest of the project site.

Seepage through the clay core is expected to be small, on the order of a few gallons per minute for the entire embankment. However, a properly filtered drain under the downstream slope is necessary to lower the phreatic surface to keep seepage from outcropping on the slope and to enhance embankment stability. A linear drain located at the toe of the core can keep the line of seepage low in the embankment. The drain will need a gravel zone to transmit the water surrounded by filter sand to prevent erosion of the embankment soils. It would also be useful to place the more sandy fill materials against the downstream boundary of the core to help transmit seepage to the drain.

Underseepage is expected to be small wherever the slurry trench cutoff can extend to a thick bed of clay. Some seepage will occur, however, and foundation drainage is needed to prevent excessive uplift beneath the embankment and the development of springs or boils at the toe. Silt and clay layers about ten feet thick overlie the permeable sand deposits at several of the boring locations. This natural clay blanket will tend to confine the water and keep a blanket drain or toe drain from being effective. Vertical sand drains extending through the clay and well into the sand would relieve uplift. The sand drains can be one-to-two-foot diameter columns of sand placed into augered or jetted holes. Another approach would be to monitor the uplift after construction and install relief wells only where needed.

Various systems can be considered to convey the water collected by the drains to the stream. A series of finger drains running from the internal linear drain to the toe drain can be less expensive and more effective than a continuous blanket drain. Like the linear drain, the finger drains will need a gravel zone to transmit the water and a surrounding sand zone to hold the foundation and embankment soil particles in place.

A conceptual cross section is shown in Figure 6. The sand drains and linear drain are located at the downstream edge of the clay core to maximize their effectiveness. Finger drains convey the water to a toe drain, which also helps keep the water table a few feet below the ground surface at the toe. Because the valley is broad and flat, it would be desirable to provide outlets from the toe drain into several drainage channels.

Special drainage will probably be needed at the west abutment. There is natural seepage from the hillside now, which will likely be increased by seepage through the sandy

abutment soils unless the slurry trench cutoff is extended far into the abutment. A drainage blanket with collector pipes will probably be needed under the downstream slope of the embankment and on the hillside downstream from the dam.

4.1.9 Embankment Settlement

The foundation soils include compressible clays and loose sands in the upper 30 feet. The most compressible location found is at Boring B-103, where we estimate that a 65-foot high embankment will cause about two feet of foundation settlement. About one-half of this amount can be expected to occur during construction. Some consolidation of the embankment itself will occur after construction; one to two percent of the height is common. The embankment should be cambered about two feet above the design crest elevation to assure that the required freeboard will exist after settlement occurs.

4.2 **Structure Foundations**

The service spillway will be constructed in a cut about 20 feet deep. Materials at that depth will likely be dense marine silty sands and hard clays. Reasonable bearing pressures and small settlements can be expected. Subdrainage will be needed to prevent seepage from creating excessive uplift beneath the outlet channel bottom. The soils can provide reasonable sideshear resistance for soil anchors if needed.

The outlet works are expected to consist of an intake tower, one or two large conduits beneath the embankment, and a stilling basin. Differential settlement of the intake tower and conduits will be an important issue if they are constructed in the floodplain. It would be preferable to construct the outlet works on the dense soils available at relatively shallow depth in the abutments.

High groundwater levels will be a factor in construction of the outlet works at any likely location. Underdrains or anchors may be required to prevent flotation of the stilling basin under some conditions.

4.3 **Slope Protection**

4.3.1 Downstream Slope

Grass is the preferred and most economical protection for the downstream slope. A slope of 2.5 horizontal to 1 vertical can be mowed, but 3 horizontal to 1 vertical is preferable. The random fill materials are generally suitable to support grass if placement of the cleaner sand near the surface is avoided.

4.3.2 Upstream Slope

Riprap would be expensive because sources are distant from the site. The project is well suited for the use of soil cement on the upstream slope. The silty sands found at Borings S-1 through S-3 appear suitable for soil cement. The sand will need to be tested and a mix design developed as work progresses.

5.0 CONCLUSIONS

The following conclusions and recommendations are intended for preliminary design. Additional studies will be needed for confirmation and detailed design.

- The dam foundation through the floodplain and east abutment consists of 20 to 30 feet of weak clays and permeable fine silty and clayey sands underlain by hard marine clays.
- The west abutment foundation consists of up to 100 feet of mostly sandy soils with intermittent clay layers.
- The materials from required excavations will be mostly lean clays and silty and clayey sands that can be used in the outer zones of the dam. Fat clays can be separated and used in the core.
- Lean and fat clay for the dam core and silty sand for soil cement are available in sufficient quantities from the reservoir areas above the floodplain within two miles of the dam site. The silty sand and floodplain materials can also be used in the outer zones of the embankment. Additional testing for dispersivity will be needed to confirm that the clays are suitable for use in the core.
- The typical section shown in Figure 6 can be used for preliminary design.
- Special seepage control and drainage measures will be needed at the west abutment.
- Preliminary design should assume two feet of post-construction settlement of the dam crest across the floodplain.
- Long-term seepage loss from the reservoir is expected to be small.

6.0 LIMITATIONS

This report was prepared specifically for use by Freese and Nichols, Inc., the Angelina-Neches River Authority, and the Texas Water Development Board. Information and recommendations presented in this report should not be used for other projects or purposes. This investigation is preliminary in scope. Additional geologic and geotechnical investigations will be needed for design.

The discussion and conclusions presented in this report are based on our analysis of the data collected for this project. Additive conclusions or recommendations made from these data by others are their responsibility.

APPENDIX A
FIGURES

Legend

Qal - Alluvium

Qt - Fluvatile Terrace Deposits

Es - Sparta Sand

Ew - Weches Formation

Eqc - Queen City Sand

Er - Reklaw Formation

Ec- Carrizo Sand

— — Fault

NOTE:

MAP IS A PORTION OF "GEOLOGIC ATLAS OF TEXAS, PALESTINE SHEET", 1967, BUREAU OF ECONOMIC GEOLOGY, THE UNIVERSITY OF TEXAS AT AUSTIN, AUSTIN, TEXAS 78713

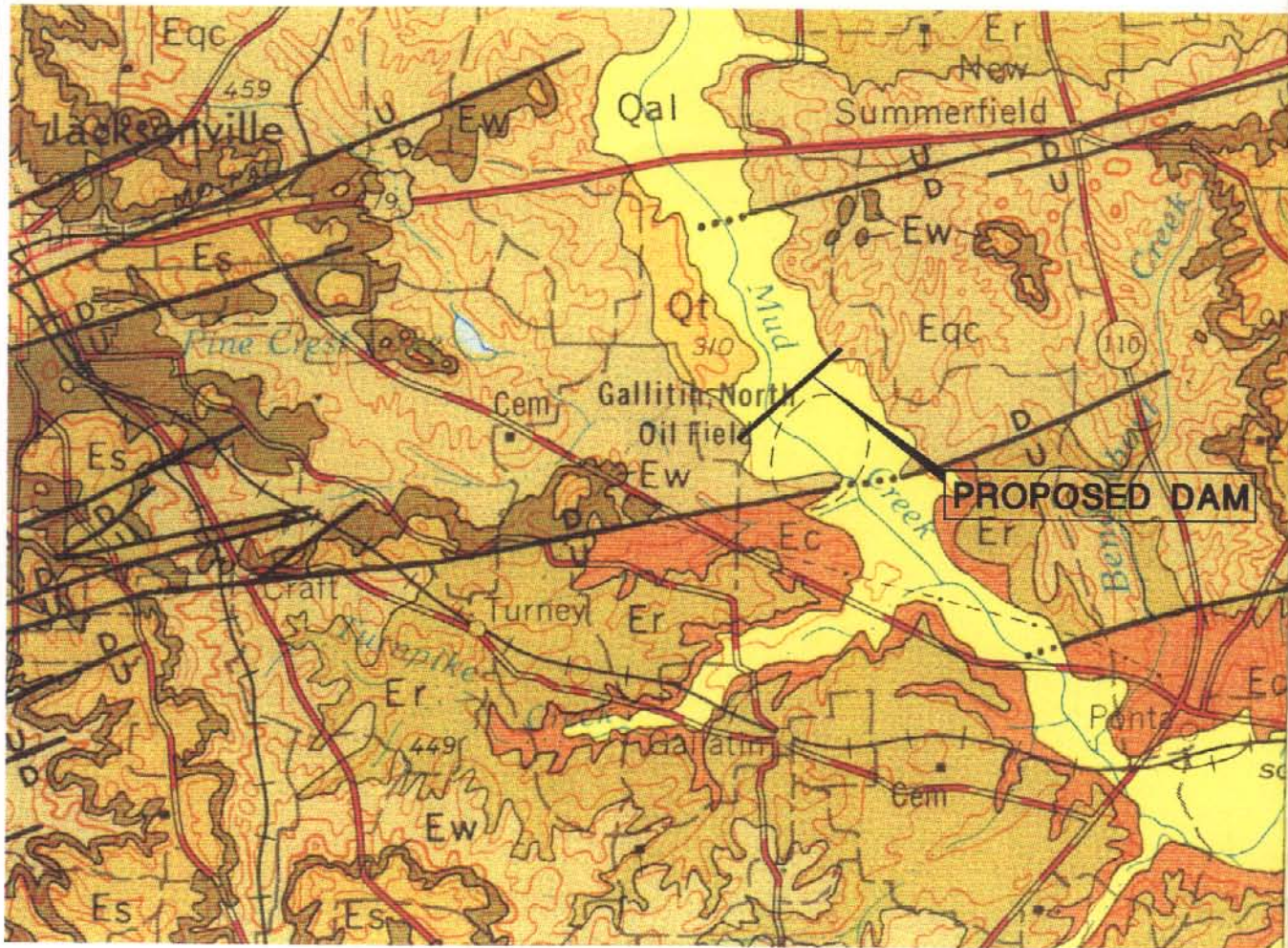

EXPLANATION

SEDIMENTARY ROCKS

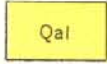

Alluvium

Clay, silt, and sand, organic matter abundant locally; includes point bar, natural levee, stream channel, backswamp, indistinct terrace, and perhaps some Deweyville deposits, as well as a few small inliers of Tertiary formations



Deweyville Formation

Sand, silt, and clay, some gravel; includes point bar, natural levee, stream channel, and backswamp deposits at a level only slightly higher than the present flood plain; sand coarser than in alluvium; surface characterized by relict meanders of much larger radius of curvature than those of present streams, some scattered pimple mounds; thickness locally more than 50 feet

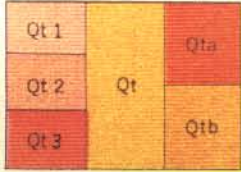

Fluvialite terrace deposits

Gravel, sand, and silt. Differences in elevation between top surfaces of terraces and level of flood plain are as follows: along Trinity River, Qt1, 15-20 feet; Qt2, 30-40 feet; Qt3, 50-75 feet except in vicinity of Palestine dome where higher elevations on terrace surface indicate post-depositional uplift. Along Sabine River, Qta, 25-55 feet; Qtb, 50-70 feet. Elsewhere, Qt, terraces undivided. (Terraces in 50-75-foot range may in part correlate with Beaumont Formation)

QUATERNARY

Recent
Recent or Late
Pleistocene (?)

Eocene



Sparta Sand

Quartz sand, very fine to fine grained, commonly with lignitic clay and silt partings, soft to indurated, light gray to brownish gray; weathers yellowish brown to reddish brown, local beds and upper few feet cemented by limonite; thickness 200± feet



Weches Formation

Includes from top down Therrill, Viesca, and Tyus Members, not separately mapped, glauconitic, glauconitic marl, quartz sand, and clay, grayish green; weathers to yellowish brown and reddish brown, limonitic, banded, clay-ironstone; marine megafossils abundant; forms scarp; thickness 50-90 feet; lower part equivalent to upper part of Cane River Formation in Louisiana



Queen City Sand

Quartz sand, fine grained, brownish gray; thin irregular interbeds of light brown to light gray clay; a few glauconitic lentils; clay-ironstone beds and concretions common. Sand weathers pale red to grayish orange, clay weathers brownish gray to very light gray, resulting in a distinctive intermixing of colors characteristic of the formation. Thickness 325 feet in southwestern Anderson County, feathers out eastward in western San Augustine County



Reklaw Formation

Includes from top down Marquez and Newby Members, not separately mapped; thickness 30-130 feet, thins eastward. Marquez Member, clay and silt, carbonaceous, lentils of glauconitic clay-ironstone contain marine megafossil imprints, calcite and glauconite more abundant in eastern Nacogdoches County, brownish black, brownish gray, and reddish brown; weathers light brown to light gray; merges eastward in Louisiana with light yellowish-gray clay of the lower part of the Cane River Formation. Newby Member, glauconite, quartz sand, and clay, grayish green; weathers to moderate brown and yellowish-brown clay-ironstone; marine megafossils common; forms low scarp; thickness 5-40 feet



Carrizo Sand

Quartz sand, some feldspar and chert grains. Upper part—sand, fine grained, some medium gray to dark gray clay and silt interbeds and black carbonaceous partings, some sparry calcite cement, thinly bedded, light gray to brownish gray; weathers pale red to reddish brown and light gray. Lower part—sand, fine to medium grained, thickly bedded to massive. Thickness 60-150 feet

ANGELINA AND NECHES RIVER AUTHORITY
LAKE EASTEX

INC. REVISION	BY	DATE	FAM JOB NO. ANR01289
			FILE GM LEGND.DWG
			DATE FEB. 2003
			DESIGNED CNE

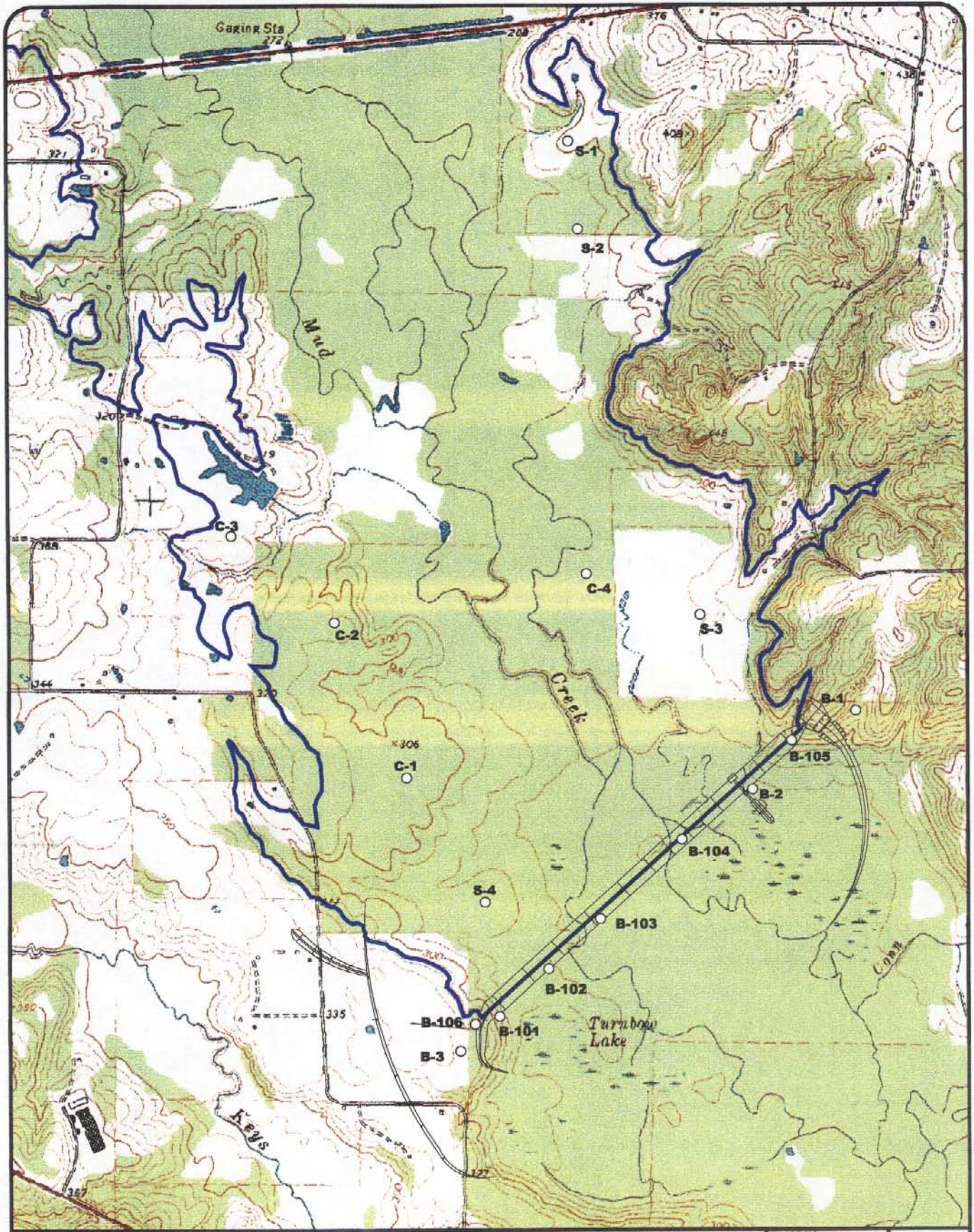

FREESSE + NICHOLS
 4055 International Plaza, Suite 200
 Fort Worth, Texas 76109 4895
 817 735 7300



**Boring Location Plan
 USGS Topo Base Map**

2000 0 2000 Feet



FN JOB NO	ANR01289
FILE	BORINGS.APR
DATE	October 29, 2002
SCALE	1:24,000
DESIGNED	LDC
DRAFTED	LDC

2

FIGURE

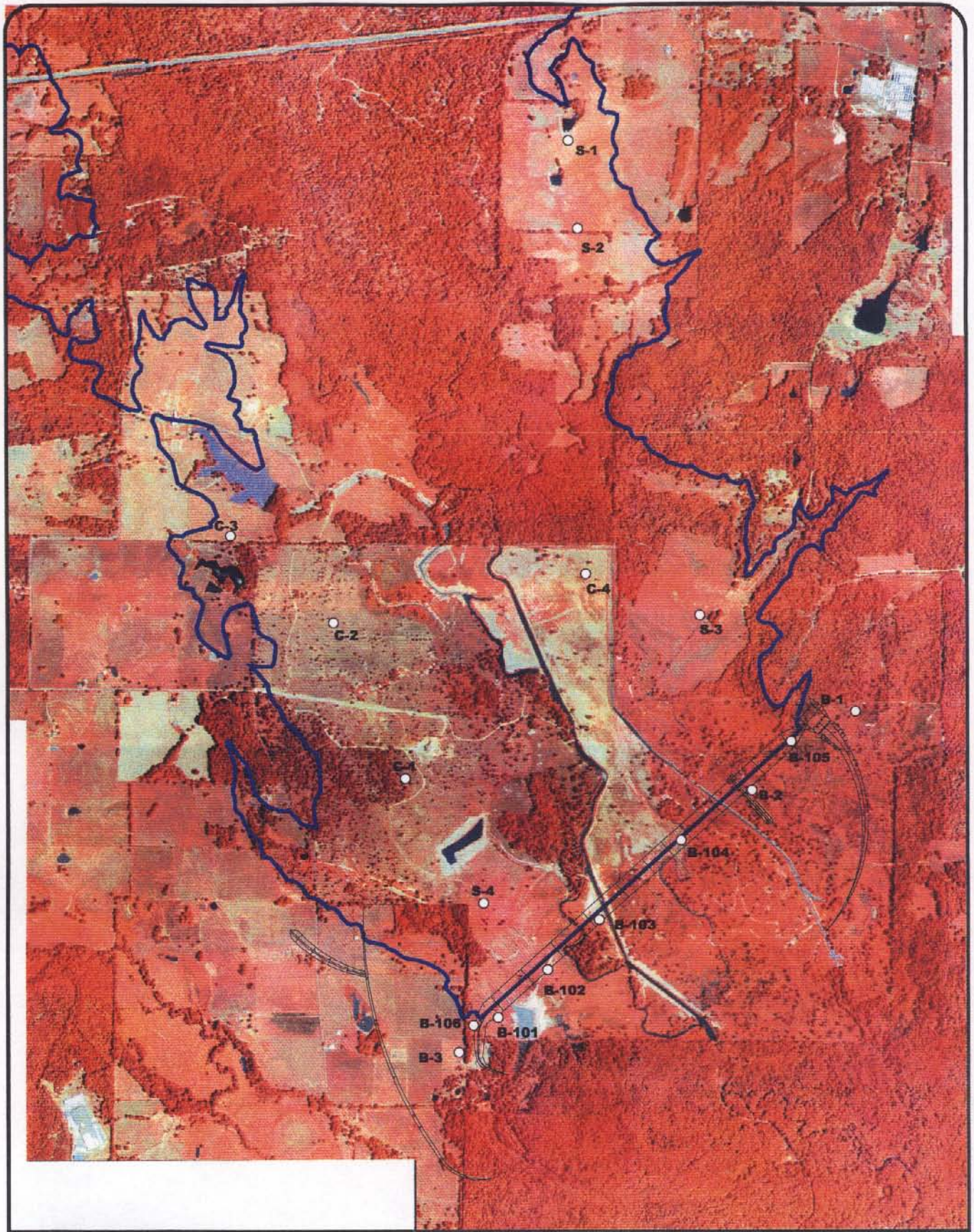

FREESE + NICHOLS
 4055 International Plaza Suite 200
 Fort Worth, Texas 76109 4895
 817 735 7300



**Boring Location Plan
 Aerial Photo August 2001**

2000 0 2000 Feet

FN JOB NO	ANR01288
FILE	BORINGS.APP
DATE	October 28, 2002
SCALE	1:24,000
DESIGNED	LDC
DRAFTED	LDC

3

FIGURE

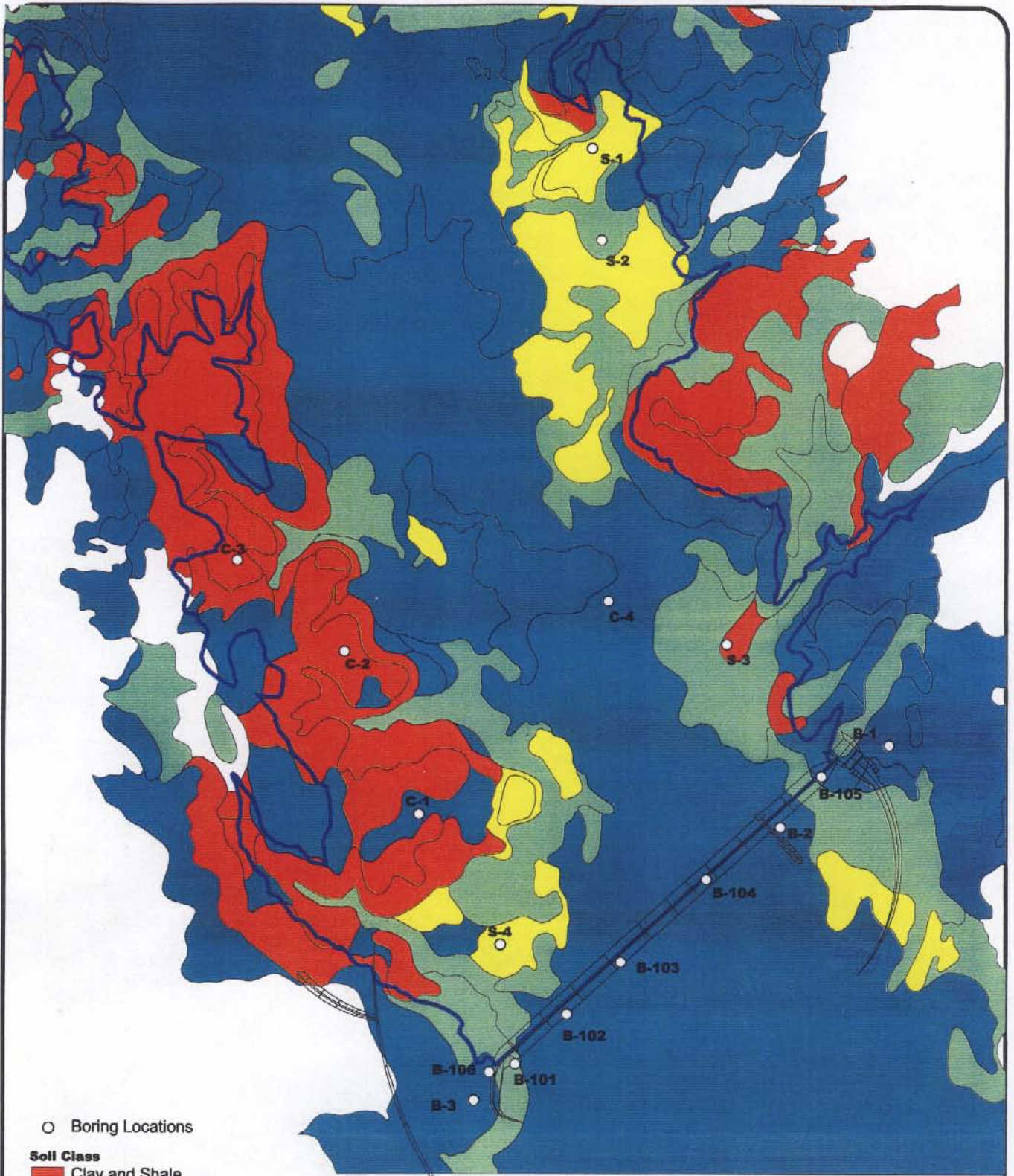

- Boring Locations
- Soil Class**
- Clay and Shale
- Sandy Clay Loam, Sandy Clay & Clay Loam
- Loamy Fine Sand
- Sandy Loam & Sandy Clay Loam
- Normal Pool Elevation - 315-feet

Soil Types based on USDA Cherokee Soil Survey, 1959

FREESE • NICHOLS
 4055 International Plaza Suite 200
 Fort Worth, Texas 76109 4895
 817 735 7300

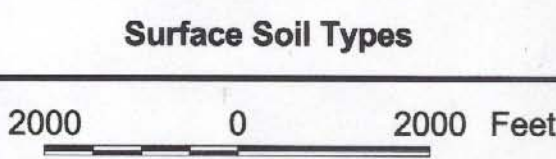
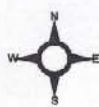

FN JOB NO	ANR01285
FILE	BORINGS.APR
DATE	October 29, 2007
SCALE	1:24,000
DESIGNED	LDC
DRAFTED	LDC

4

FIGURE

LEGEND

SOIL TYPE SYMBOL - SEE BELOW

N = STANDARD PENETRATION RESISTANCE, BLOWS/FOOT OR 50 BLOWS/NUMBER OF INCHES
 P = POCKET PENETROMETER STRENGTH, TONS/FT²
 F = PERCENT PASSING #200 SIEVE
 W = WATER CONTENT, %
 LL = LIQUID LIMIT, %
 PL = PLASTIC LIMIT, %

- SAND (SP, SP-SM, SP-SC)
- CLAYEY SAND (SC)
- SILTY SAND (SM)
- LEAN CLAY (CL)
- FAT CLAY (CH)
- SILT (ML)
- CLAYEY GRAVEL (GC)
- SILTY GRAVEL (GM)

WATER LEVEL AT COMPLETION
 WATER LEVEL NUMBER OF HOURS SHOWN AFTER COMPLETION
 APPARENT PERCHED WATER TABLE

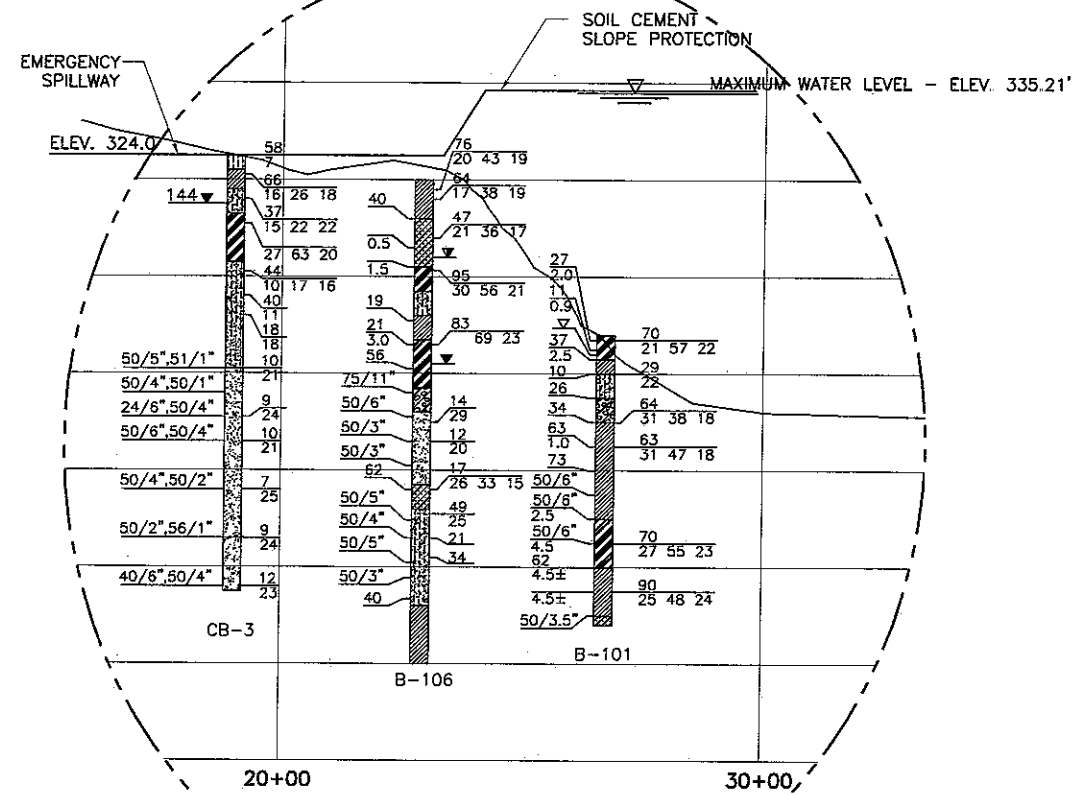

DETAIL
 1"=400'

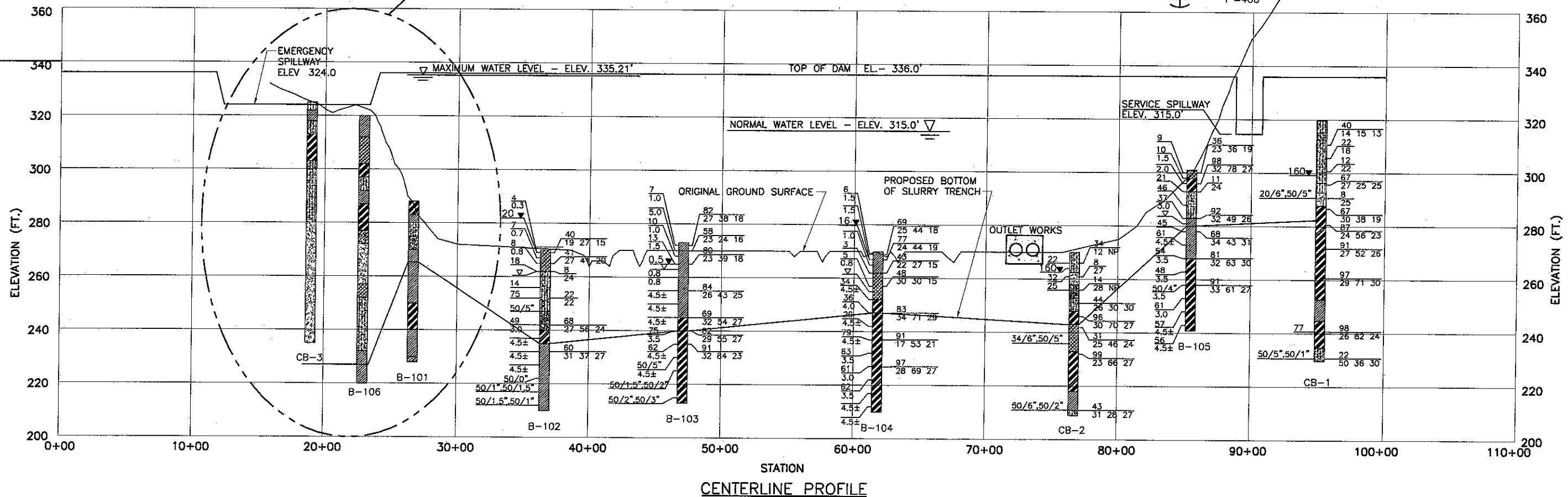

CENTERLINE PROFILE
 1"=400'

NOT FOR CONSTRUCTION
 THIS DOCUMENT IS INTENDED FOR REVIEW ONLY AND IS NOT INTENDED FOR BIDDING, PERMIT OR CONSTRUCTION PURPOSES.
 ENGINEER: CHARLES N. EASTON P.E.
 DATE: 4/4/2003

FRESE-NICHOLS
 4005 West Loop South, Suite 100
 Fort Worth, Texas 76109-4886
 817-335-7300

ANGELINA AND NECHES RIVER AUTHORITY
 LAKE EASTEX
 GEOLOGIC PROFILE
 ALONG PROPOSED DAM

NO. REVISION	BY	DATE	FEIN JOB NO.	ANR01289
			FILE	PROF-LOG.DWG
			DATE	FEB. 2003
			DESIGNED	CNE
			DRAWN	MDC
			REVISED	CAM
			CHECKED	CNE

User: MDC
 ANR01289\N\WR\GEOTECH\PROF-LOG.DWG
 FEB 05, 2003 9:37:01 A.M. LRS: 1.00
 PLS: 1.00
 REFERENCE FILE: N:\STANDARD\FN-BORDER

NOT FOR CONSTRUCTION
 THIS DOCUMENT IS RELEASED FOR THE
 PURPOSES OF RECORD REVIEW UNDER THE
 AUTHORITY OF TEXAS RULES OF COURT
 TEXAS RULES OF COURT, ARTICLE 171C
 IT IS NOT TO BE USED FOR CONSTRUCTION,
 BIDDING OR PERMIT PURPOSES.

FREESE-NICHOLS
 3330 International Plaza-Suite 200
 Fort Worth, Texas 76108-4695
 817-735-7300

ANGELINA AND NECHES RIVER AUTHORITY
 LAKE EASTEX
 TYPICAL DAM SECTION

STATION	SLOPE
23-42	5
42-70	6
70-88	4

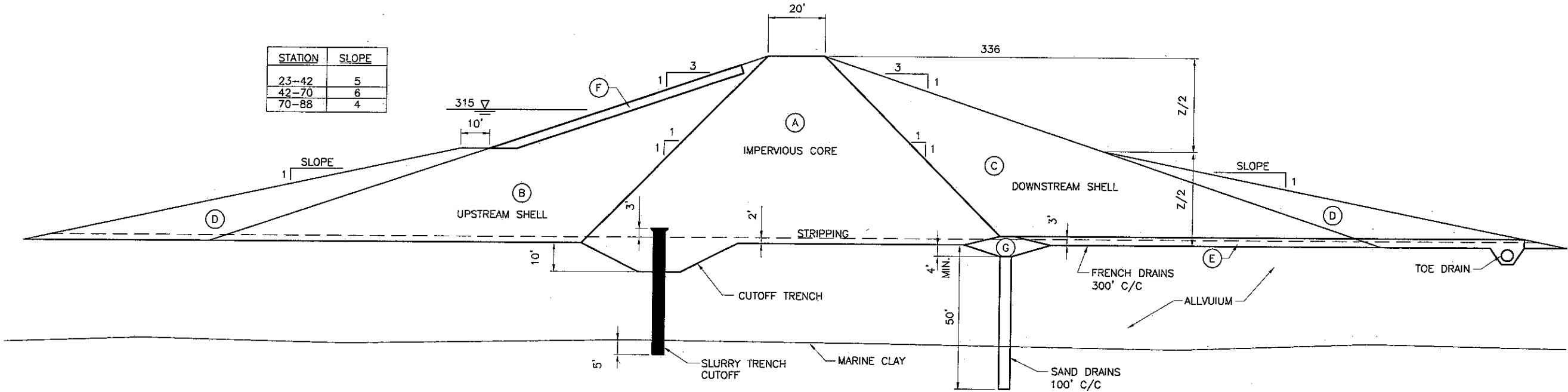

TYPICAL DAM SECTION
 SCALE: 1"=20'

ZONE	DESCRIPTION	USC	COMPACTION
A	IMPERVIOUS CORE	CL & CH	95% STD, OPT ±2%
B	UPSTREAM SHELL	CL, SM, SC	do
C	DOWNSTREAM SHELL	CL, SM, SC	do
D	STABILIZING FILL	RANDOM	90% STD, OPT ±4%
E	FINGER DRAIN	GP & SP	65% RELATIVE DENSITY
F	SLOPE PROTECTION	SOIL CEMENT	95% STD
G	LINEAR DRAIN	GP & SP	65% RELATIVE DENSITY

NO.	REVISION	BY	DATE	FILE	DATE	DESIGNED	DRAWN	CHECKED
0				ANR01289 DAM.DWG	FEB. 2003	ONE	CAM	MDC

Bar is one inch on original drawing. If not one inch on this sheet, adjust scale.

VERIFY SCALE
 0

ACAD Plot 15.08s (LMS Tech) User: MDC
 [ANR01289]N:\WR\GEOTECH\DAM.DWG LAYOUT: Layout1
 FEB 05, 2003 8:04:43 A.M. LTS: 1.00 PLSJTS: 1 TWIST: 0.0
 REFERENCE FILE: N:\STANDARD\FN-BORDER

APPENDIX B
BORING LOGS

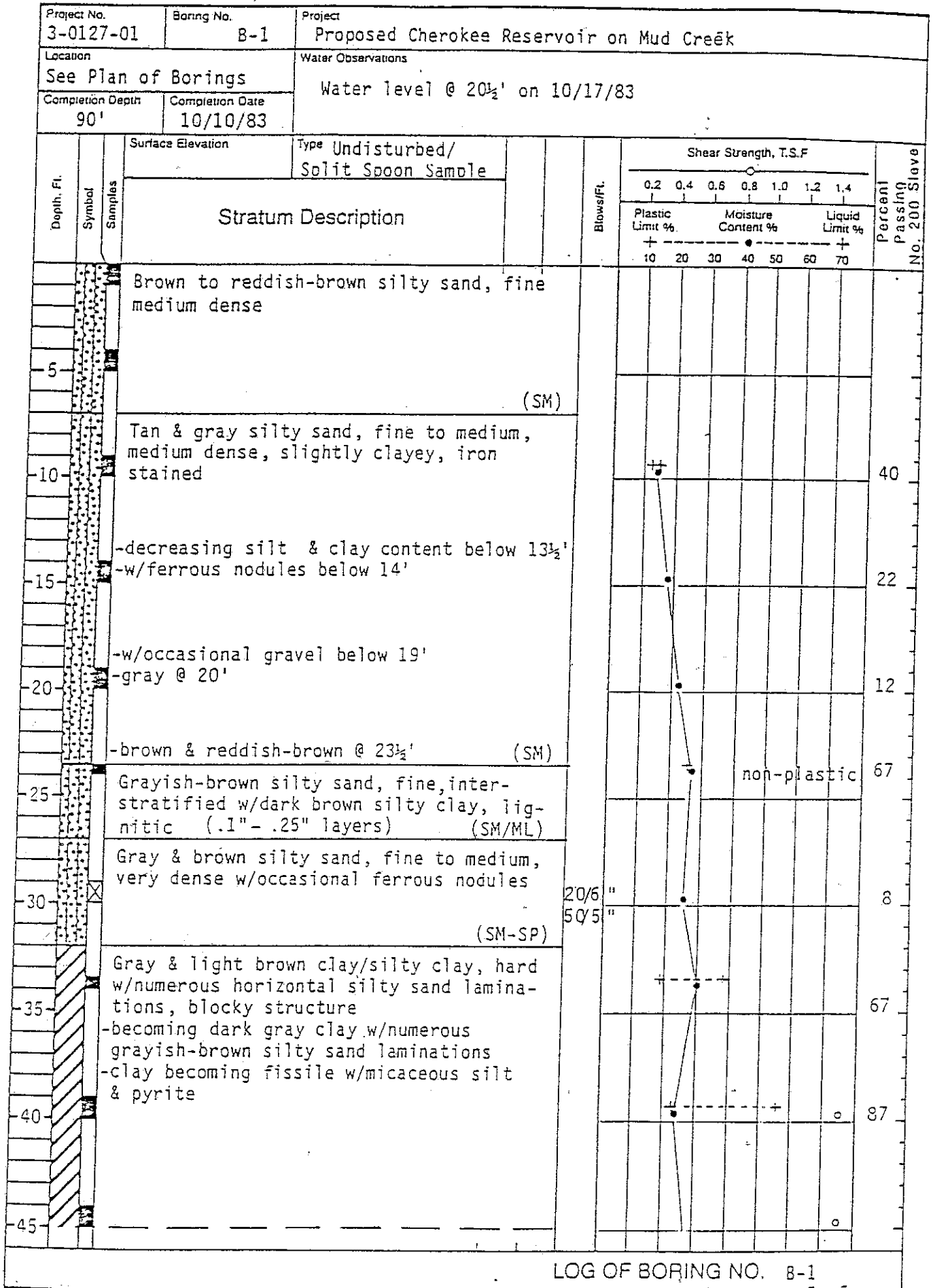

LOG OF BORING NO. B-1

Acme Engineers

PLATE 5

Project No. 3-0127-01	Boring No. 8-1 Cont.	Project Proposed Cherokee Reservoir on Mud Creek
Location See Plan of Borings		Water Observations
Completion Depth 90'	Completion Date 10/10/83	

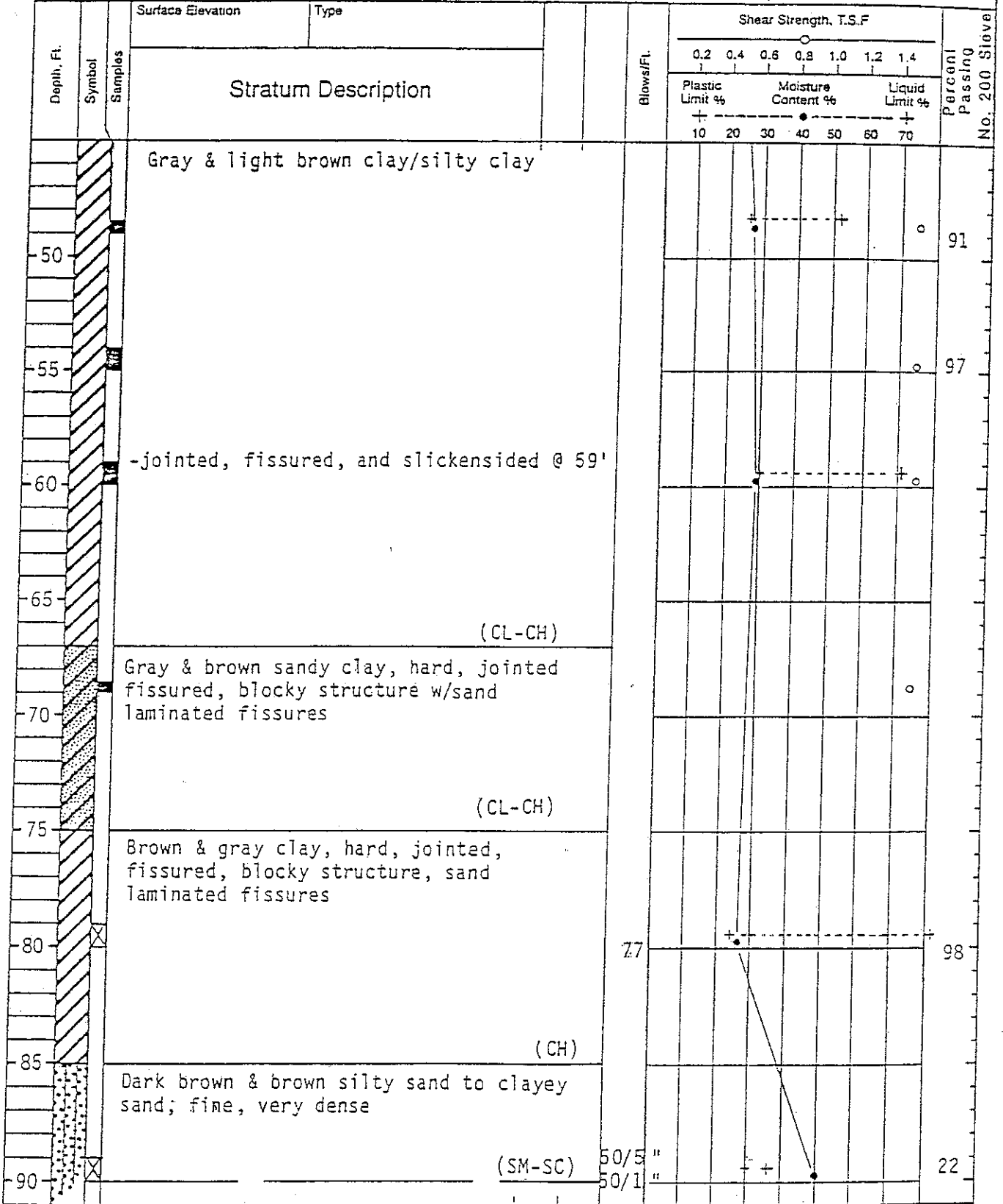

LOG OF BORING NO. 8-1 Cont.

Pone Engineers

Project No. 3-0127-01	Boring No. B-2	Project Proposed Cherokee Reservoir on Mud Creek
Location See Plan of Borings		Water Observations PVC standpipe set @ 58½' upon completion Water @ 6' on 10/17/83
Completion Depth 60'	Completion Date 10/10/83	

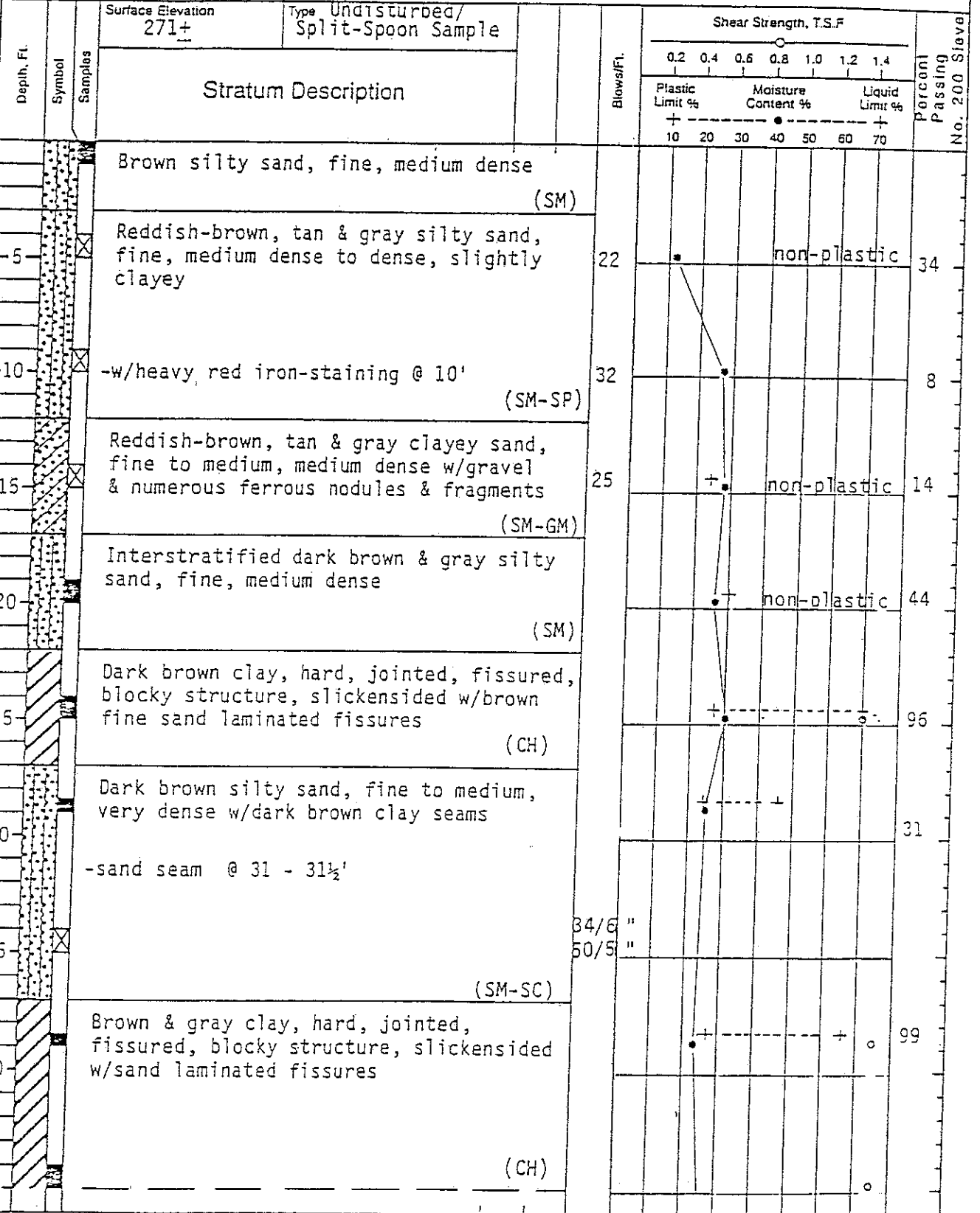

LOG OF BORING NO. B-2

Rone Engineers

Project No. 3-0127-01		Boring No. B-3	Project Proposed Cherokee Reservoir on Mud Creek						
Location See Plan of Borings			Water Observations PVC standpipe set @ 87' upon completion. Water @ 10' on 10/17/83.						
Completion Depth 90'		Completion Date 10/11/83							
Depth, Ft.	Symbol Samples	Surface Elevation 325+		Type Undisturbed/ Split-Spoon Sample	Blows/Ft.	Shear Strength, T.S.F.			Percent Passing No. 200 Sieve
						0.2 0.4 0.6 0.8 1.0 1.2 1.4	Plastic Limit %	Moisture Content %	
Stratum Description						+	+	+	
		Tan sandy silt/silty sand, fine, firm to very stiff, medium dense w/roots (ML)							58
5		Reddish-brown & tan silty sandyclay, hard (CL)							66
10		Tan & reddish-brown silty sand, medium dense to dense w/numerous ferrous nodules & fragments (SM)						non-plastic	37
15		Reddish-brown, tan & gray clay, very stiff, jointed, blocky structure (CH)							
20									
25		Reddish-brown, tan & gray silty sand to clayey sand, fine, very dense w/iron stains -decreasing clay content below 25'							44
30									40
35									
40									18
45		-fine to medium below 44' (SM-SC)			50/8"				10
					50/1"				

LOG OF BORING NO. B-3

Rare Engineers

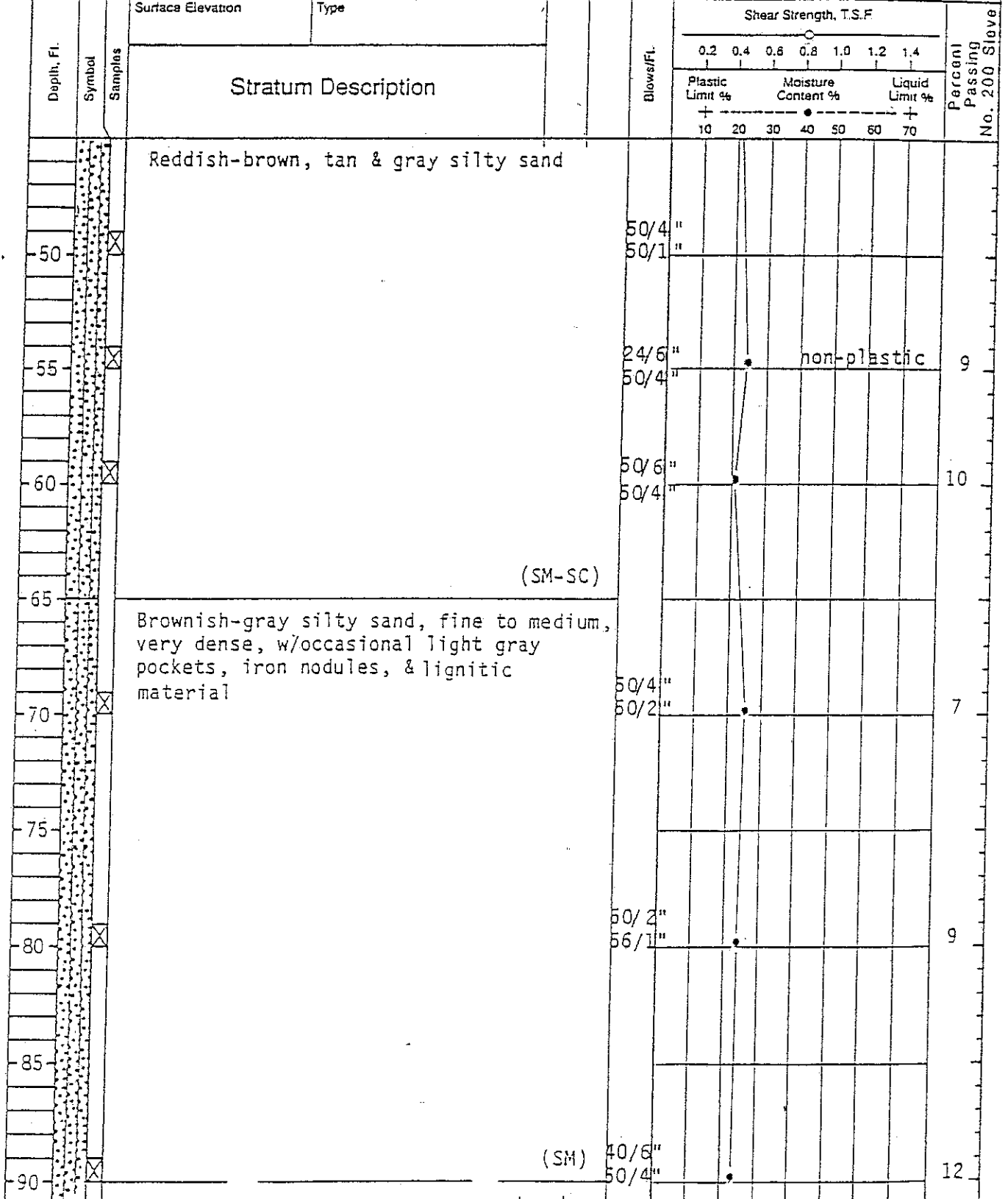
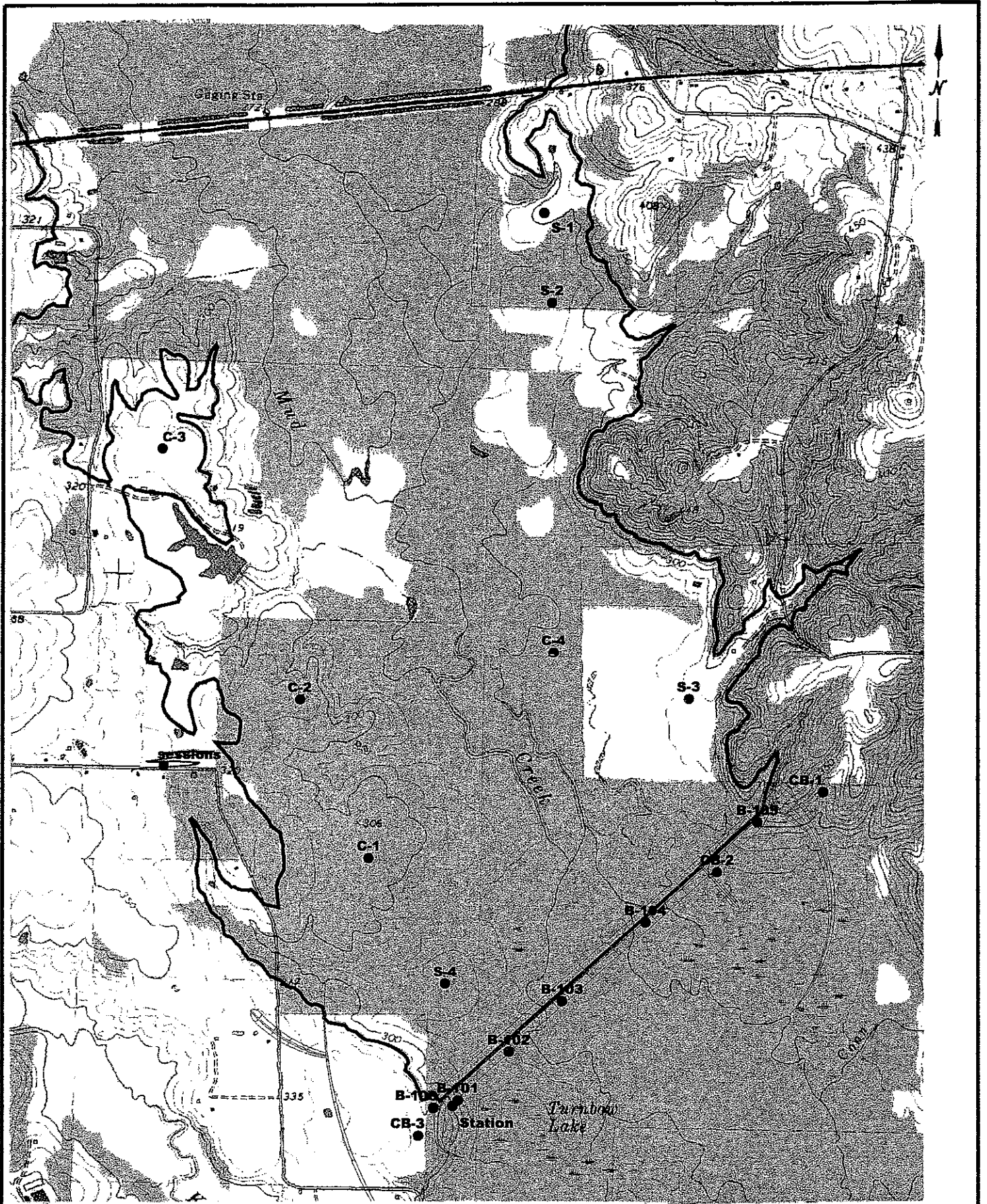

PLATE 9

Project No. 3-0127-01	Boring No. B-3 Cont.	Project
Location See Plan of Borings		Water Observations
Completion Depth 90'	Completion Date 10/11/83	



LOG OF BORING NO. B-3 Cont.

0502

ETTL
ENGINEERS &
CONSULTANTS
 MAIN OFFICE
 1717 East Erwin
 Tyler, Texas 75702
 (903) 585-4421

LAKE EASTEX
JACKSONVILLE, TEXAS

PLATE 1 - PLAN OF BORINGS
JOB NO.: G 1066-02
DATE: AUG. 2002 **SCALE: N.T.S.**

APPROVED BY:

DRAWN BY:
 K.C.R.



**ETTL
ENGINEERS &
CONSULTANTS**

MAIN OFFICE
1717 East Erwin
Tyler, Texas 75702
(903) 595-4421

MATERIAL DESCRIPTION

SANDY LEAN CLAY(CL) red; with organics

--reddish tan; with sand

--red and tan; with sand

CLAYEY SAND(SC) dense; red; mottled

--loose; red and tan; saturated

FAT CLAY(CH) stiff; gray

SILTY SAND(SM) reddish tan

SILTY CLAY(CL-ML) very stiff; tan and gray

FAT CLAY WITH SAND(CH) very stiff; red and tan

--hard; saturated

IRON OXIDE CEMENTED SANDSTONE SEAMS WITH CLAY(GC)

SILTY SAND(SM) very dense; tan and gray

--tan

DEPTH (ft)
0
10
20
30
40
50
WATER LEVEL

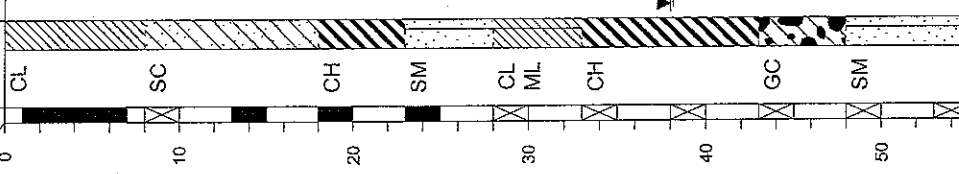

LOG OF BORING B-106

PROJECT: Lake Eastex
Jacksonville, Texas
PROJECT NO.: G 1066-02

BORING TYPE: Rotary Wash

DATE: 7/24/02

SURFACE ELEVATION: 320.0

FIELD STRENGTH DATA	BLOW COUNT ●	Qu (tsf) ▲	PPR (tsf) ■	Torvane (tsf) ◆	DRY DENSITY (pcf)	COMPRESSIONIVE STRENGTH (tsf)	FAILURE STRAIN (%)	CONFINING PRESSURE (1)	Natural Moisture Content and Atterberg Limits			MINUS #200 SIEVE (%)	OTHER TESTS PERFORMED (Page Ref #)	
									Plastic Limit	Moisture Content	Liquid Limit			
SF	20	3.0	3.0	3.0					20	43	19	24	76	+40 Sieve =11%
SF	20	3.0	3.0	3.0					17	38	19	19	64	+40 Sieve =2%
SF	20	3.0	3.0	3.0					21	36	17	19	47	+40 Sieve =1%
N=40	20	3.0	3.0	3.0					30	56	21	35	95	+40 Sieve =3%
P=0.5	20	3.0	3.0	3.0										
P=1.5	20	3.0	3.0	3.0										
SF	20	3.0	3.0	3.0										
N=19	20	3.0	3.0	3.0										
N=21 P=3.0	20	3.0	3.0	3.0										
N=56	20	3.0	3.0	3.0										
N=75/11"	20	3.0	3.0	3.0										
N=50/6"	20	3.0	3.0	3.0										
N=50/3"	20	3.0	3.0	3.0										

ATTERBERG LIMITS(%)		LIQUID LIMIT	PLASTIC LIMIT	PI
LL	PL			
20	43	19	24	76
17	38	19	19	64
21	36	17	19	47
30	56	21	35	95
69	23	46	83	+40 Sieve =3%
29			14	+40 Sieve =2%
20			12	+40 Sieve =2%

Notes:
Lost Circulation @ 43-45'

Key to Abbreviations:
N - SPT Data (Blows/FT)
P - Pocket Penetrometer (tsf)
T - Torvane (tsf)
L - Lab Vane Shear (tsf)

Water Level
Est: Measured: Perched:
Water Observations:
Bailed to 16' and open upon completion.
Water level @ 38' and caved to 38' after 24 hours.



**ETTL
ENGINEERS &
CONSULTANTS**

MAIN OFFICE:
1717 East Erwin
Tyler, Texas 75702
(903) 595-4421

MATERIAL DESCRIPTION

CLAYEY SAND(SC) very dense; gray
SILTY SAND(SM) very dense; gray
--with lignite
--within clay seams
LEAN CLAY(CL) hard; dark gray; laminated
with silt below 88'
--gray
Bottom of Boring @ 100'
Coordinates: X=296658.660, Y=3535318.841

WATER LEVEL

USC

SAMPLES

DEPTH (ft)

60

70

80

90

100

LOG OF BORING B-106

PROJECT: Lake Eastex
Jacksonville, Texas
PROJECT NO.: G 1066-02

BORING TYPE: Rotary Wash

DATE

7/24/02

SURFACE ELEVATION

320.0

FIELD STRENGTH DATA	BLOW COUNT ●	Qu (tsf) ▲	PPR (tsf) ■	Torvane (tsf) ◆	DRY DENSITY (pcf)	COMPRESSIVE STRENGTH (tsf)	FAILURE STRAIN (%)	CONFINING PRESSURE (1)	Natural Moisture Content and Atterberg Limits			MOISTURE CONTENT (%)	LIQUID LIMIT	PLASTIC LIMIT	PLASTICITY INDEX	MINUS #200 SIEVE (%)	OTHER TESTS PERFORMED (Page Ref #)
									Plastic Limit	Moisture Content	Liquid Limit						
N=50/3"	●	▲	■	◆													
N=62	●	▲	■	◆													
N=50/5"	●	▲	■	◆													
N=50/4"	●	▲	■	◆													+40 Sieve =27%
N=50/5"	●	▲	■	◆													+40 Sieve =34%
N=50/3"	●	▲	■	◆													
N=40	●	▲	■	◆													
SF																	
SF																	

Key to Abbreviations:
N - SPT Data (Blows/FT)
P - Pocket Penetrometer (tsf)
T - Torvane (tsf)
L - Lab Vane Shear (tsf)

Notes:
Lost Circulation @ 43-45'

Water Level Est.: Measured: Perched:
Water Observations:
Bailed to 16' and open upon completion.
Water level @ 38' and caved to 38' after 24 hours.



**ETTL
ENGINEERS &
CONSULTANTS**

MAIN OFFICE
1717 East Erwin
Tyler, Texas 75702
(903) 595-4421

MATERIAL DESCRIPTION

SANDY SILT (ML) tan
SANDY FAT CLAY (CH) tan and red
FAT CLAY (CH) tan, red, and gray
SANDY FAT CLAY (CH) tan and gray

Bottom of Boring @ 20'
Coordinates: X=296358.873, Y=3536425.210

LOG OF BORING C-1

PROJECT: Lake Eastex
Jacksonville, Texas
PROJECT NO.: G 1066-02

BORING TYPE: Dry Auger

FIELD STRENGTH DATA	● BLOW COUNT	20	40	60	80
	▲ Qu (tsf)	1.0	2.0	3.0	4.0
	■ PPR (tsf)	1.0	2.0	3.0	4.0
	◆ Torvane (tsf)	1.0	2.0	3.0	4.0

DRY DENSITY (pcf)		
COMPRESSIVE STRENGTH (tsf)		
FAILURE STRAIN (%)		
CONFINING PRESSURE (1)		
Natural Moisture Content and Atterberg Limits		
PLASTIC LIMIT		PL
LIQUID LIMIT		LL
PLASTICITY INDEX		PI

MOISTURE CONTENT (%)	8	22	27	24
LIQUID LIMIT	LL	52	74	50
PLASTIC LIMIT	PL	21	27	18
PLASTICITY INDEX	PI	31	47	32
MINUS #200 SIEVE (%)	68	67	90	61
OTHER TESTS PERFORMED (Page Ref #)		+40 Sieve =5%	+40 Sieve =7%	+40 Sieve =2%
		+40 Sieve =3%		

DATE: 7/25/02
SURFACE ELEVATION: 305.0

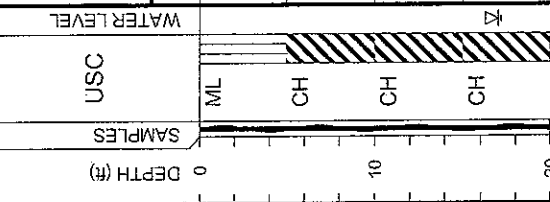

Key to Abbreviations:
N - SPT Data (Blows/FT)
P - Pocket Penetrometer (tsf)
T - Torvane (tsf)
L - Lab Vane Shear (tsf)

Water Level Est.: Measured: Perched:
Water Observations: Seepage @ 17' while drilling. Dry and open upon completion.

Notes:



**ETTL
ENGINEERS &
CONSULTANTS**

MAIN OFFICE
1717 East Erwin
Tyler, Texas 75702
(903) 595-4421

MATERIAL DESCRIPTION

FAT CLAY(CH) tan and red

--with sand

--red and gray

--gray and tan

Bottom of Boring @ 20'

Coordinates: X=296045.699, Y=3537123.588

WATER LEVEL

USC

SAMPLES

DEPTH (ft)

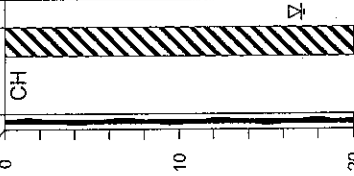

LOG OF BORING C-2

PROJECT: Lake Eastex
Jacksonville, Texas
PROJECT NO.: G 1066-02

BORING TYPE: Dry Auger

DATE

7/25/02

SURFACE ELEVATION

310.0

MOISTURE CONTENT (%)	ATTERBERG LIMITS(%)			MINUS #200 SIEVE (%)	OTHER TESTS PERFORMED (Page Ref #)
	LIQUID LIMIT	PLASTIC LIMIT	PLASTICITY INDEX		
29	81	24	57	91	+40 Sieve =2%
20	57	20	37	78	+40 Sieve =10%
23	58	20	38	90	+40 Sieve =2%
29	62	20	42	95	+40 Sieve =1%

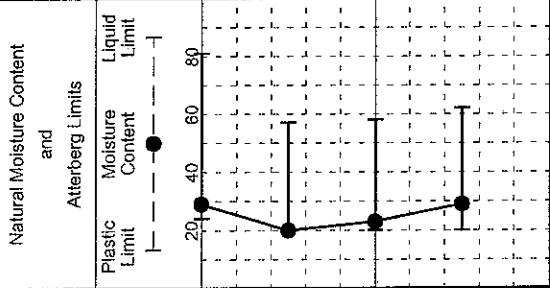

DRY DENSITY (pcf)	COMPRESSION STRENGTH (tsf)	FAILURE STRAIN (%)	CONFINING PRESSURE (1)

FIELD STRENGTH DATA	BLOW COUNT	Qu (tsf)	PPR (tsf)	Tonvane (tsf)
	20	2.0	2.0	1.0
	40	3.0	3.0	2.0
	60	4.0	4.0	3.0
	80	4.0	4.0	4.0

Notes:

Key to Abbreviations:

- N - SPT Data (Blows/Ft)
- P - Pocket Penetrometer (tsf)
- T - Tonvane (tsf)
- L - Lab Vane Shear (tsf)

Water Level Est: Measured: Perched:
 Water Observations: Seepage @ 17' while drilling. Dry and open upon completion.



**ETTL
ENGINEERS &
CONSULTANTS**

MAIN OFFICE
1717 East Erwin
Tyler, Texas 75702
(903) 595-4421

MATERIAL DESCRIPTION

FAT CLAY(CH) tan and red

--tan and gray

LEAN CLAY WITH SAND(CL) tan

Bottom of Boring @ 20'

Coordinates: X=295590.801, Y=3537513.193

DEPTH (#)
0
10
20
SAMPLES
USC
WATER LEVEL

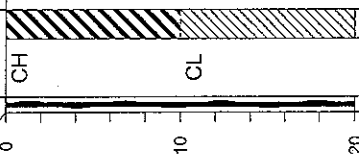

LOG OF BORING C-3

PROJECT: Lake Eastex
Jacksonville, Texas
PROJECT NO.: G 1066-02

BORING TYPE: Dry Auger

DATE

7/25/02

SURFACE ELEVATION
313.0

MOISTURE CONTENT (%)	ATTERBERG LIMITS(%)			MINUS #200 SIEVE (%)	OTHER TESTS PERFORMED (Page Ref #)
	LIQUID LIMIT LL	PLASTIC LIMIT PL	PLASTICITY INDEX PI		
19	80	23	57	92	+40 Sieve =1%
18	54	19	35	80	+40 Sieve =2%
19	46	17	29	80	+40 Sieve =4%
19	40	17	23	72	+40 Sieve =2%

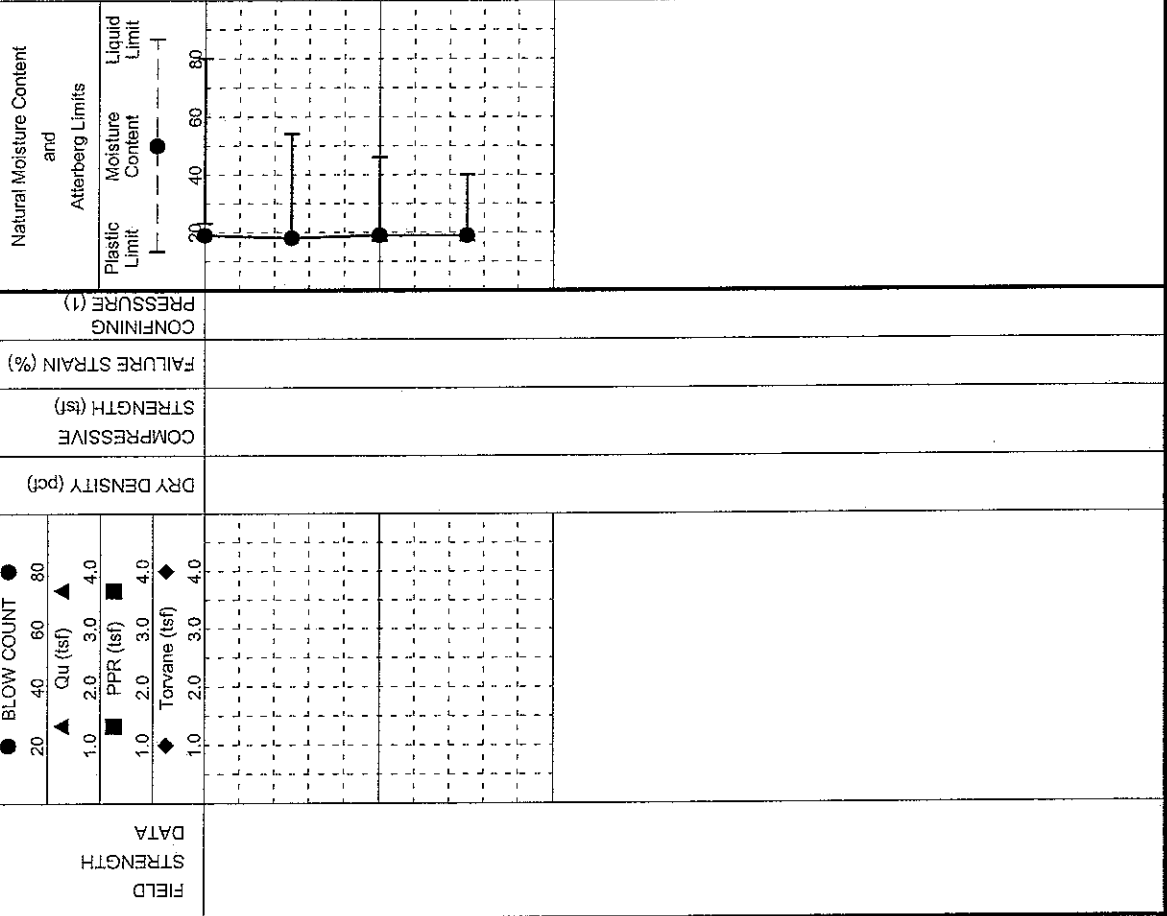

FIELD STRENGTH DATA	DRY DENSITY (pcf)	COMPRESSIVE STRENGTH (tsf)	FAILURE STRAIN (%)	CONFINING PRESSURE (1)
<ul style="list-style-type: none"> ● BLOW COUNT ▲ Qu (tsf) ■ PPR (tsf) ◆ Torvane (tsf) 				

Water Level

Water Observations:

Est. Measured: Perched:

Dry and open upon completion.

Key to Abbreviations:
N - SPT Data (Blows/Ft)
P - Pocket Penetrometer (tsf)
T - Torvane (tsf)
L - Lab Vane Shear (tsf)

Notes:



**ETTL
ENGINEERS &
CONSULTANTS**

MAIN OFFICE
1717 East Erwin
Tyler, Texas 75702
(903) 595-4421

MATERIAL DESCRIPTION

SILTY SAND(SM) tan
SANDY LEAN CLAY(CL) tan, red, and gray
SILTY SAND(SM) tan
SILTY SANDY(SM) red; with iron oxide cemented sandstone gravel

Bottom of Boring @ 20'

Coordinates: X=297462.164, Y=3537341.244

WATER LEVEL

USC

SAMPLES

DEPTH (ft)

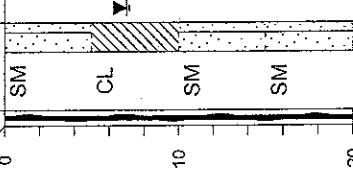

LOG OF BORING C-4

PROJECT: Lake Eastex
Jacksonville, Texas
PROJECT NO.: G 1066-02

BORING TYPE: Dry Auger

DATE

7/26/02

SURFACE ELEVATION

272.0

MOISTURE CONTENT (%)	ATTERBERG LIMITS(%)			MINUS #200 SIEVE (%)	OTHER TESTS PERFORMED (Page Ref #)
	LIQUID LIMIT	PLASTIC LIMIT	PLASTICITY INDEX		
12	LL	PL	PI	48	+40 Sieve =2%
19	31	16	15	53	+40 Sieve =1%
23				23	+40 Sieve =1%
22				12	+40 Sieve =39%

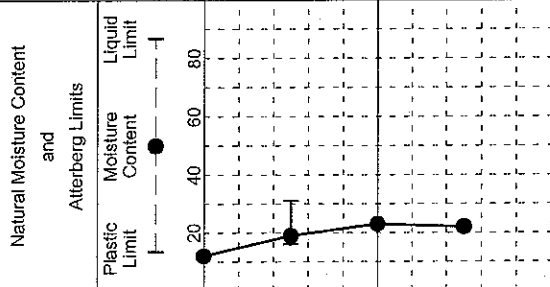

DRY DENSITY (pcf)	COMPRESSIVE STRENGTH (tsf)	FAILURE STRAIN (%)	CONFINING PRESSURE (1)

FIELD STRENGTH DATA	BLOW COUNT		Qu (tsf)	PPR (tsf)	Torrane (tsf)
	20	40			

Notes:

Key to Abbreviations:

- N - SPT Data (Blows/Ft)
- P - Pocket Penetrometer (tsf)
- T - Torrane (tsf)
- L - Lab Vane Shear (tsf)

Water Level Est.: Measured: Perched:
 Water Observations: Seepage @ 11' while drilling. Water level @ 7' and caved to 7' upon completion.



**ETTL
ENGINEERS &
CONSULTANTS**

MAIN OFFICE
1717 East Erwin
Tyler, Texas 75702
(903) 595-4421

MATERIAL DESCRIPTION

SAND(SP) tan

SILTY SAND(SM) tan

Bottom of Boring @ 20'

Coordinates: X=297090.134, Y=3539278.225

WATER LEVEL

USC

SAMPLES

DEPTH (ft)

SP

SM

LOG OF BORING S-1

PROJECT: Lake Eastex
Jacksonville, Texas

PROJECT NO.: G 1066-02

BORING TYPE: Dry Auger

DATE

7/26/02

SURFACE ELEVATION

302.0

ATTERBERG
LIMITS(%)

LIQUID LIMIT

PLASTIC LIMIT

PI

MINUS #200 SIEVE (%)

OTHER TESTS
PERFORMED
(Page Ref #)

Natural Moisture Content
and
Atterberg Limits

Plastic Limit

Moisture Content

Liquid Limit

PI

DRY DENSITY (pcf)

COMPRESSIONIVE STRENGTH (tsf)

FAILURE STRAIN (%)

CONFINING PRESSURE (1)

FIELD STRENGTH DATA

● BLOW COUNT

▲ Qu (tsf)

■ PPR (tsf)

◆ Torvane (tsf)

MOISTURE CONTENT (%)

28

11

12

11

14

+40 Sieve =1%

+40 Sieve =1%

+40 Sieve =1%

+40 Sieve =1%

Notes:

Key to Abbreviations:

N - SPT Data (Blows/Ft)

P - Pocket Penetrometer (tsf)

T - Torvane (tsf)

L - Lab Vane Shear (tsf)

Water Level Est: Measured: Perched:
Water Observations: Seepage @ 13' while drilling. Dry and open upon completion.



**ETTLL
ENGINEERS &
CONSULTANTS**

MAIN OFFICE
1717 East Erwin
Tyler, Texas 75702
(903) 595-4421

MATERIAL DESCRIPTION

SILTY SAND(SM) gray and tan

--gray

--tan

SANDY SILT(ML) tan and gray

Bottom of Boring @ 20'

Coordinates: X=297130.847, Y=3538885.191

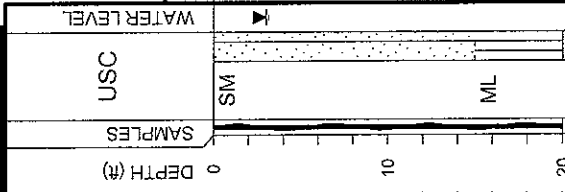

LOG OF BORING S-2

PROJECT: Lake Eastex
Jacksonville, Texas
PROJECT NO.: G 1066-02

BORING TYPE: Dry Auger

DATE
7/26/02

SURFACE ELEVATION
287.0

MOISTURE CONTENT (%)	23
ATTERBERG LIMITS(%)	
LIQUID LIMIT	PL
PLASTIC LIMIT	PI
PLASTICITY INDEX	PL - PI
MINUS #200 SIEVE (%)	16
OTHER TESTS PERFORMED (Page Ref #)	+40 Sieve =2% +40 Sieve =1% +40 Sieve =1% +40 Sieve =1%

FIELD STRENGTH DATA	
BLOW COUNT	● 20 40 60 80
Qu (tsf)	▲ 1.0 2.0 3.0 4.0
PPR (tsf)	■ 1.0 2.0 3.0 4.0
Torvane (tsf)	◆ 1.0 2.0 3.0 4.0
DRY DENSITY (pcf)	
COMPRESSIVE STRENGTH (tsf)	
FAILURE STRAIN (%)	
CONFINING PRESSURE (1)	
Natural Moisture Content and Atterberg Limits	

Water Level Est.: Measured: Perched:
 Water Observations: Water level @ 3' and open upon completion.

Key to Abbreviations:
 N - SPT Data (Blows/Ft)
 P - Pocket Penetrometer (tsf)
 T - Torvane (tsf)
 L - Lab Vane Shear (tsf)

Notes:



**ETTL
ENGINEERS &
CONSULTANTS**

MAIN OFFICE
1717 East Erwin
Tyler, Texas 75702
(903) 595-4421

MATERIAL DESCRIPTION

SILTY SAND(SM) tan

Bottom of Boring @ 20'

WATER LEVEL

USC

SAMPLES

DEPTH (ft)

0 10 20

LOG OF BORING S-3

PROJECT: Lake Eastex
Jacksonville, Texas
PROJECT NO.: G 1066-02

BORING TYPE: Dry Auger

DATE

7/26/02

SURFACE ELEVATION

283.0

FIELD STRENGTH DATA	BLOW COUNT ● 20 40 60 80 ▲ Qu (tsf) 1.0 2.0 3.0 4.0 ■ PPR (tsf) 1.0 2.0 3.0 4.0 ◆ Torvane (tsf) 1.0 2.0 3.0 4.0	DRY DENSITY (pcf)	COMPRESSIVE STRENGTH (tsf)	FAILURE STRAIN (%)	CONFINING PRESSURE (1)	Natural Moisture Content and Atterberg Limits			MOISTURE CONTENT (%)	ATTERBERG LIMITS (%)			OTHER TESTS PERFORMED (Age Ref #)	
						Plastic Limit	Moisture Content	Liquid Limit		LIQUID LIMIT	PLASTIC LIMIT	PL		PI
						●	●	●	5				18	+40 Sieve =1%
													16	+40 Sieve =0%
													17	+40 Sieve =1%
													17	+40 Sieve =7%

Key to Abbreviations:

- N - SPT Data (Blows/Ft)
- P - Pocket Penetrometer (tsf)
- T - Torvane (tsf)
- L - Lab Vane Shear (tsf)

Notes:

Est: Measured: Perched:
Water level @ 13' and open upon

Water Level
Water Observations:
completion.



**ETTL
ENGINEERS &
CONSULTANTS**

MAIN OFFICE
1717 East Erwin
Tyler, Texas 75702
(903) 585-4421

LOG OF BORING S-4

PROJECT: Lake Eastex
Jacksonville, Texas
PROJECT NO.: G 1066-02
BORING TYPE: Dry Auger

DATE: 7/25/02
SURFACE ELEVATION: 283.0

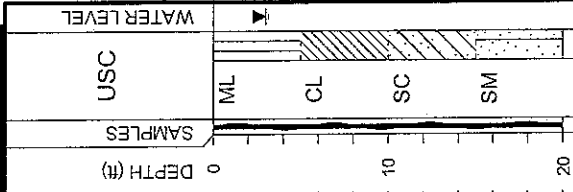

SAMPLES	WATER LEVEL	MATERIAL DESCRIPTION
USC		SANDY SILT (ML) tan
ML		SANDY LEAN CLAY (CL) red, tan, and gray
CL		CLAYEY SAND (SC) red, tan, and gray
SC		SILTY SAND (SM) tan
SM		Bottom of Boring @ 20'

FIELD STRENGTH DATA	BLOW COUNT	DRY DENSITY (pcf)	COMPRESSIONIVE STRENGTH (tsf)	FAILURE STRAIN (%)	CONFINING PRESSURE (1)	Natural Moisture Content and Atterberg Limits
	<ul style="list-style-type: none"> ● BLOW COUNT ▲ Qu (tsf) ■ PPR (tsf) ◆ Torvane (tsf) 					Plastic Limit Moisture Content Liquid Limit
	20, 40, 60, 80					Plastic Limit Moisture Content Liquid Limit

MOISTURE CONTENT (%)		PLASTIC LIMIT		LIQUID LIMIT		PLASTICITY INDEX		MINUS #200 SIEVE (%)	OTHER TESTS PERFORMED (Page Ref #)
LL	PL	PL	PI	LL	PL	PI			
14	20	18	2	20	18	2	66	+40 Sieve =2%	
19	28	15	13	28	15	13	57	+40 Sieve =6%	
18	28	16	12	28	16	12	40	+40 Sieve =32%	
31							29	+40 Sieve =23%	

Water Level: Est: Measured: Perched:
 Water Observations: Seepage @ 11' while drilling. Water level @ 3' and open upon completion.
 Key to Abbreviations:
 N - SPT Data (Blows/Ft)
 P - Pocket Penetrometer (tsf)
 T - Torvane (tsf)
 L - Lab Vane Shear (tsf)
 Notes:

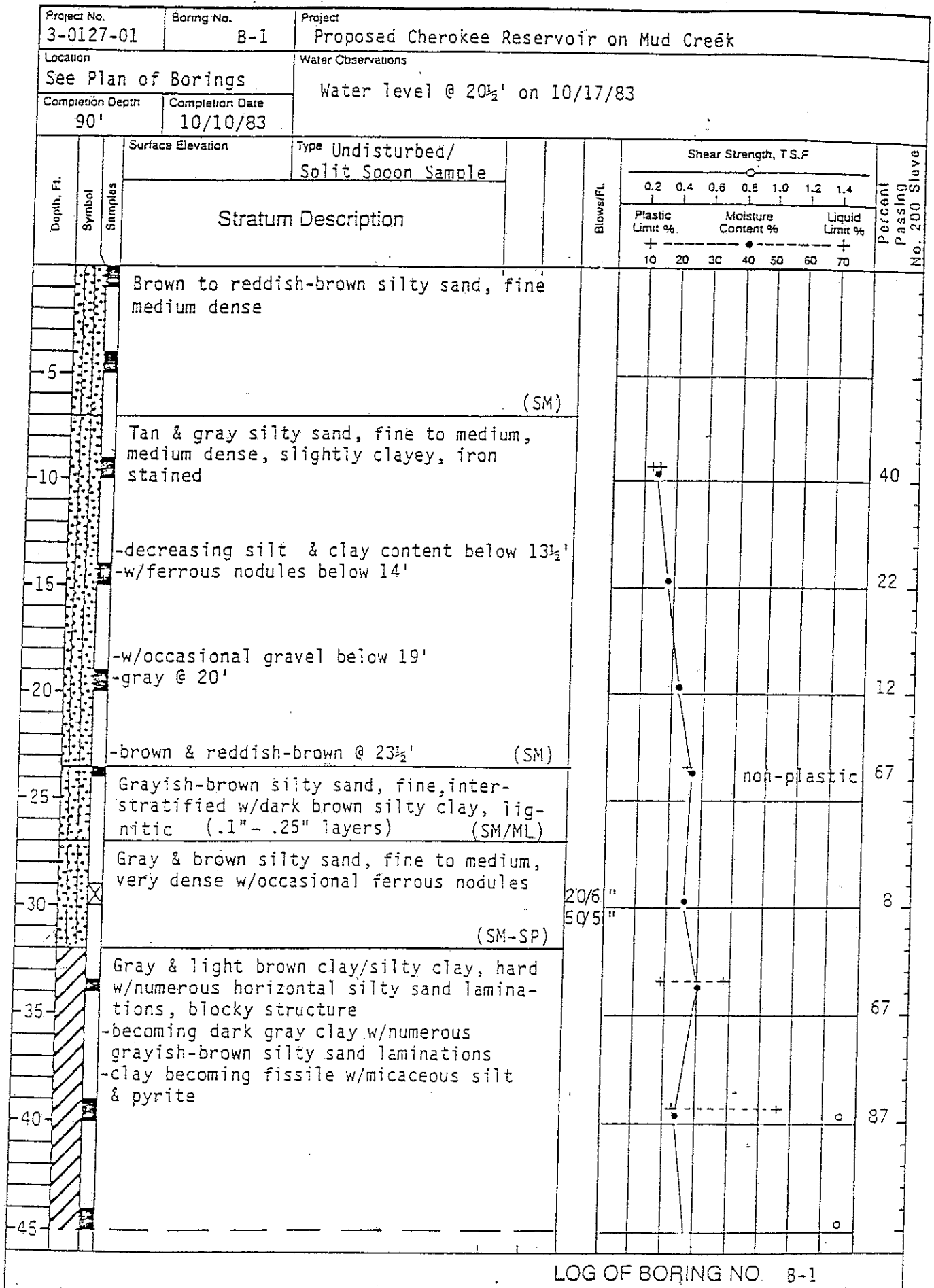

LOG OF BORING NO. B-1

Rone Engineers

PLATE 5

Project No. 3-0127-01	Boring No. B-1 Cont.	Project Proposed Cherokee Reservoir on Mud Creek
Location See Plan of Borings		Water Observations
Completion Depth 90'	Completion Date 10/10/83	

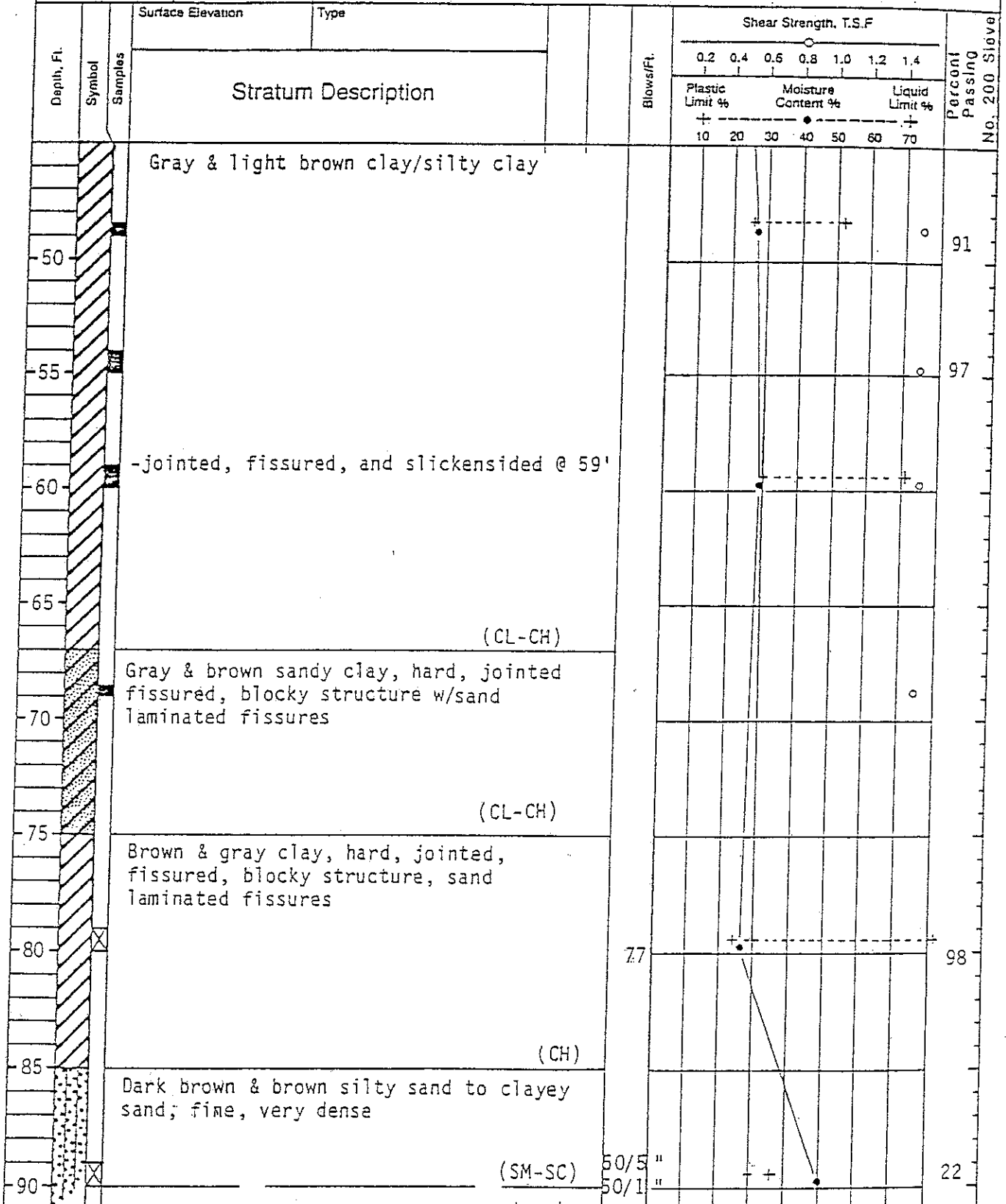

LOG OF BORING NO. B-1 Cont.

Rone Engineers

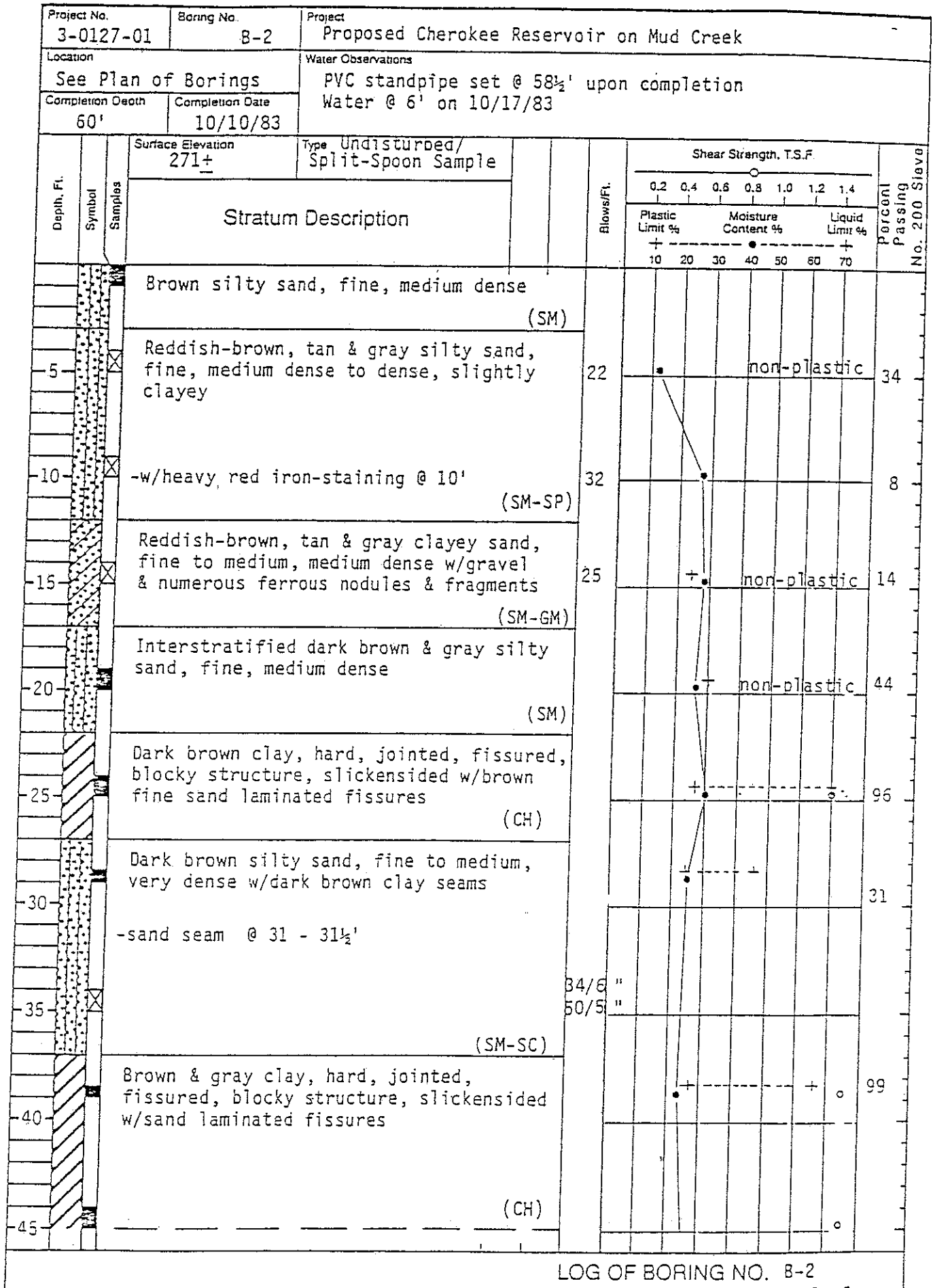

LOG OF BORING NO. B-2

Rone Engineers

Project No. 3-0127-01		Boring No. B-2 Cont.		Project					
Location See Plan of Borings			Water Observations						
Completion Depth 60'		Completion Date 10/10/83							
Depth, Ft.	Symbol	Samples	Surface Elevation	Type	Blows/Ft.	Shear Strength, T.S.F.			Percent Passing No. 200 Sieve
			Stratum Description			0.2 0.4 0.6 0.8 1.0 1.2 1.4	Plastic Limit %	Moisture Content %	
-50			Brown & gray clay						
-55			Brown & gray clay, hard w/grayish-brown silty sand seams, blocky structure						
-60			(CL-CH) Dark brown & brown silty sand, fine, very dense (SM)		50/6" 50/2"				43
-65									
-70									
-75									
-80									
-85									
-90									

LOG OF BORING NO. B-2 Cont.
Rone Engineers

20510

Project No. 3-0127-01	Boring No. B-3 Cont.	Project
Location See Plan of Borings		Water Observations
Completion Depth 90'	Completion Date 10/11/83	

Depth, Ft.	Symbol	Samples	Surface Elevation	Type	Stratum Description	Blows/Ft.	Shear Strength, T.S.F.			Percent Passing No. 200 Sieve
							Plastic Limit %	Moisture Content %	Liquid Limit %	
					Reddish-brown, tan & gray silty sand					
50						50/4" 50/1"				
55						24/6" 50/4"		non-plastic		9
60						50/6" 50/4"				10
					(SM-SC)					
65					Brownish-gray silty sand, fine to medium, very dense, w/occasional light gray pockets, iron nodules, & lignitic material					
70						50/4" 50/2"				7
75										
80						50/2" 56/1"				9
85										
90						(SM) 40/6" 50/4"				12

LOG OF BORING NO. 8-3 Cont.

Rone Engineers

PLATE 10

2050

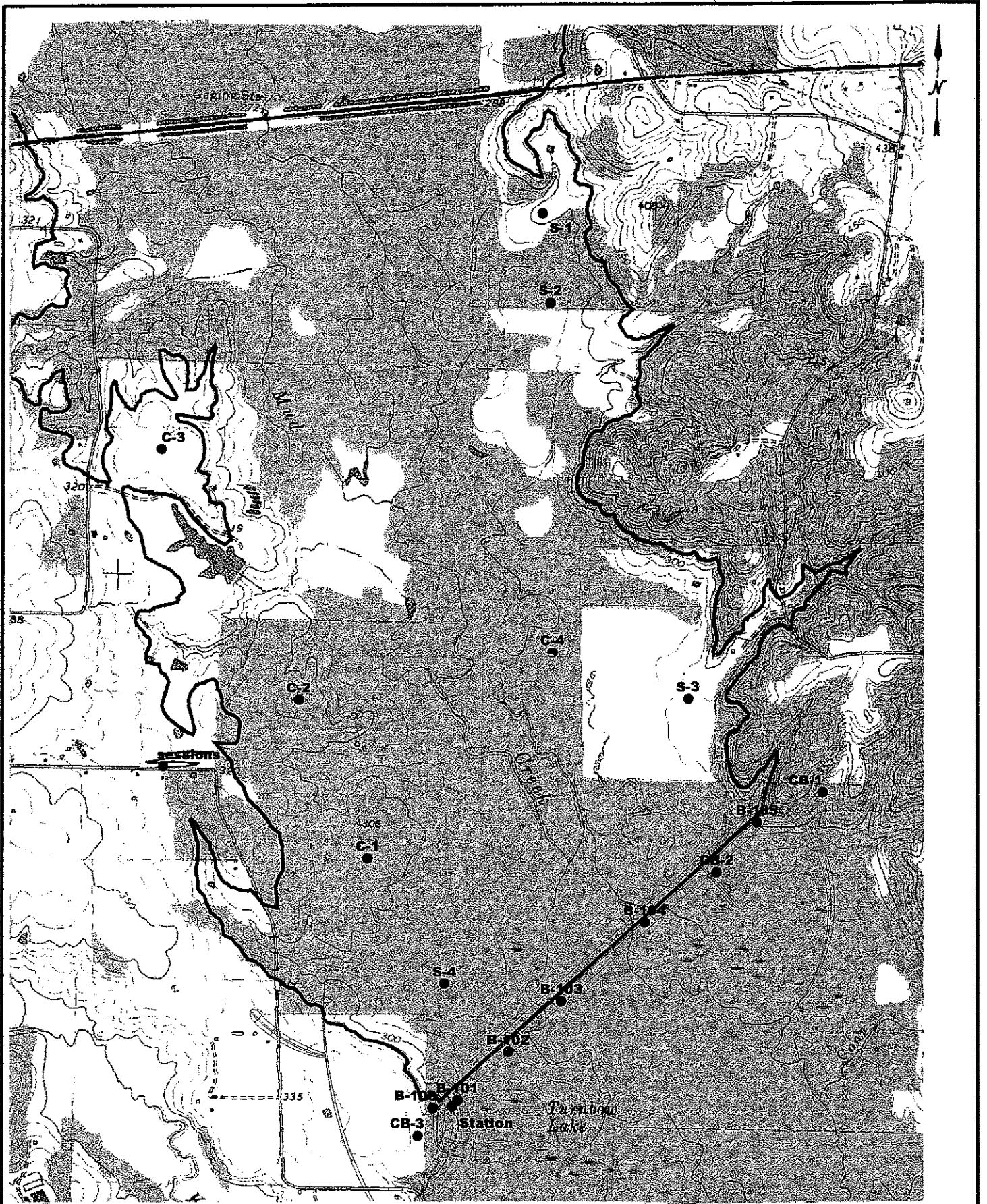

ETTL
ENGINEERS &
CONSULTANTS
 MAIN OFFICE
 1717 East Brash
 Tyler, Texas 75702
 (903) 595-4421

LAKE EASTEX
JACKSONVILLE, TEXAS

PLATE 1 - PLAN OF BORINGS
JOB NO.: G 1066-02
DATE: AUG. 2002 **SCALE: N.T.S.**

APPROVED BY:

DRAWN BY:
K.C.R.



**ETTL
ENGINEERS &
CONSULTANTS**

MAIN OFFICE
1717 East Erwin
Tyler, Texas 75702
(903) 595-4421

LOG OF BORING B-106

PROJECT: Lake Eastex
Jacksonville, Texas
PROJECT NO.: G 1066-02

BORING TYPE: Rotary Wash

DATE: 7/24/02

SURFACE ELEVATION
320.0

DEPTH (ft)	USC	WATER LEVEL	MATERIAL DESCRIPTION	FIELD STRENGTH	TORVANE (tsf)	PPR (tsf)	QU (tsf)	BLOW COUNT	DRY DENSITY (pcf)	COMPRESSIVE STRENGTH (tsf)	FAILURE STRAIN (%)	CONFINING PRESSURE (1)	Natural Moisture Content and Atterberg Limits			MOISTURE CONTENT (%)	ATTERBERG LIMITS (%)			MINUS #200 SIEVE (%)	OTHER TESTS PERFORMED (Page Ref #)
													Plastic Limit	Moisture Content	Liquid Limit		LL	PL	PL		
0														20	43	19	24	76	+40 Sieve =11%		
10	CL		SANDY LEAN CLAY(CL) red; with organics --reddish tan; with sand --red and tan; with sand	SF										17	38	19	19	64	+40 Sieve =2%		
10	SC		CLAYEY SAND(SC) dense; red; mottled	N=40										21	36	17	19	47	+40 Sieve =1%		
20	CH		--loose; red and tan; saturated	P=0.5										30	56	21	35	95	+40 Sieve =3%		
20	CH		FAT CLAY(CH) stiff; gray	P=1.5																	
20	SM		SILTY SAND(SM) reddish tan	SF																	
30	CL ML		SILTY CLAY(CL-ML) very stiff; tan and gray	N=19																	
30	CH		FAT CLAY WITH SAND(CH) very stiff; red and tan	N=21 P=3.0																	
40	CH		--hard; saturated	N=56																	
40	GC		IRON OXIDE CEMENTED SANDSTONE SEAMS WITH CLAY(GC)	N=75/11"																	
50	SM		SILTY SAND(SM) very dense; tan and gray	N=50/6"																	
50	SM		--tan	N=50/3"																	

Water Level: Est. Measured: Perched:

Water Observations: Bailed to 16' and open upon completion.
Water level @ 38' and caved to 38' after 24 hours.

Key to Abbreviations:
N - SPT Data (Blows/Ft)
P - Pocket Penetrometer (tsf)
T - Torvane (tsf)
L - Lab Vane Shear (tsf)

Notes:
Lost Circulation @ 43-45'



**ETTL
ENGINEERS &
CONSULTANTS**

MAIN OFFICE
1717 East Erwin
Tyler, Texas 75702
(903) 595-4421

MATERIAL DESCRIPTION

CLAYEY SAND(SC) very dense; gray
SILTY SAND(SM) very dense; gray
--with lignite
--within clay seams
LEAN CLAY(CL) hard; dark gray; laminated with silt below 88'
--gray
Bottom of Boring @ 100'
Coordinates: X=296658.660, Y=3535318.841

WATER LEVEL
USC
SAMPLES
DEPTH (ft)

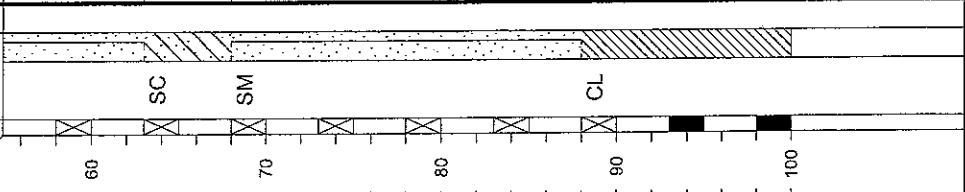

LOG OF BORING B-106

PROJECT: Lake Eastex
Jacksonville, Texas
PROJECT NO.: G 1066-02
BORING TYPE: Rotary Wash

DATE: 7/24/02
SURFACE ELEVATION: 320.0

FIELD STRENGTH DATA	BLOW COUNT	DRY DENSITY (pcf)	COMPRESSIVE STRENGTH (tsf)	FAILURE STRAIN (%)	CONFINING PRESSURE (1)	Natural Moisture Content and Atterberg Limits		MOISTURE CONTENT (%)	ATTERBERG LIMITS (%)			MINUS #200 SIEVE (%)	OTHER TESTS PERFORMED (Page Ref #)
						Plastic Limit	Liquid Limit		LL	PL	PI		
N=50/3"	● 20, ▲ 3.0, ■ 4.0, ◆ 2.0	80				26	33	15	18	17	+40 Sieve =1%		
N=62	● 20, ▲ 3.0, ■ 4.0, ◆ 2.0	80				25	33	15	18	17	+40 Sieve =1%		
N=50/5"	● 20, ▲ 3.0, ■ 4.0, ◆ 2.0	80									+40 Sieve =27%		
N=50/4"	● 20, ▲ 3.0, ■ 4.0, ◆ 2.0	80									+40 Sieve =27%		
N=50/5"	● 20, ▲ 3.0, ■ 4.0, ◆ 2.0	80									+40 Sieve =34%		
N=50/3"	● 20, ▲ 3.0, ■ 4.0, ◆ 2.0	80									+40 Sieve =34%		
N=40	● 20, ▲ 3.0, ■ 4.0, ◆ 2.0	80											
SF													
SF													

Notes:
Lost Circulation @ 43-45'

Key to Abbreviations:
N - SPT Data (Blows/FT)
P - Pocket Penetrometer (tsf)
T - Torvane (tsf)
L - Lab Vane Shear (tsf)

Water Level Est.: Measured: Perched:
Water Observations: Bailed to 16' and open upon completion. Water level @ 38' and caved to 38' after 24 hours.



**ETTL
ENGINEERS &
CONSULTANTS**

MAIN OFFICE
1717 East Erwin
Tyler, Texas 75702
(903) 595-4421

MATERIAL DESCRIPTION

SANDY SILT (ML) tan

SANDY FAT CLAY (CH) tan and red

FAT CLAY (CH) tan, red, and gray

SANDY FAT CLAY (CH) tan and gray

Bottom of Boring @ 20'
Coordinates: X=296358.873, Y=3536425.210

LOG OF BORING C-1

PROJECT: Lake Eastex
Jacksonville, Texas
PROJECT NO.: G 1066-02

BORING TYPE: Dry Auger

DATE: 7/25/02
SURFACE ELEVATION: 305.0

FIELD STRENGTH DATA	BLOW COUNT ● 20 40 60 80	Qu (tsf) ▲ 1.0 2.0 3.0 4.0	PPR (tsf) ■ 1.0 2.0 3.0 4.0	Tonvane (tsf) ◆ 1.0 2.0 3.0 4.0	DRY DENSITY (pcf)	COMPRESSIVE STRENGTH (tsf)	FAILURE STRAIN (%)	CONFINING PRESSURE (1)	Natural Moisture Content and Afterberg Limits			MOISTURE CONTENT (%)	ATTERBERG LIMITS (%)	MINUS #200 SIEVE (%)	OTHER TESTS PERFORMED (Page Ref #)
									Plastic Limit	Moisture Content	Liquid Limit				
												8		68	+40 Sieve =5%
												22	21	67	+40 Sieve =7%
												27	27	90	+40 Sieve =2%
												24	18	61	+40 Sieve =3%

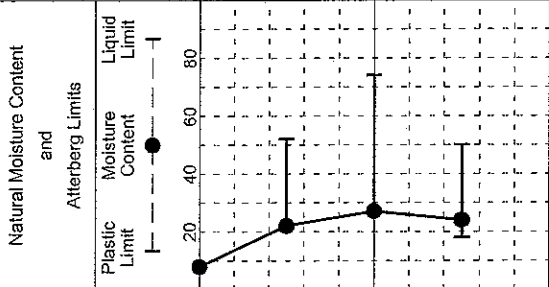

Water Level Est.: Measured: Perched:
 Water Observations: Seepage @ 17' while drilling. Dry and open upon completion.
 Key to Abbreviations:
 N - SPT Data (Blows/Ft)
 P - Pocket Penetrometer (tsf)
 T - Tonvane (tsf)
 L - Lab Vane Shear (tsf)
 Notes:



**EITL
ENGINEERS &
CONSULTANTS**

MAIN OFFICE
1717 East Erwin
Tyler, Texas 75702
(903) 595-4421

MATERIAL DESCRIPTION

FAT CLAY(CH) tan and red

--with sand

--red and gray

--gray and tan

Bottom of Boring @ 20'

Coordinates: X=296045.699, Y=3537123.588

WATER LEVEL
USC
SAMPLES
DEPTH (ft)

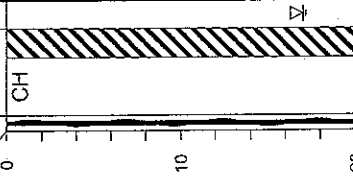

LOG OF BORING C-2

PROJECT: Lake Eastex
Jacksonville, Texas

PROJECT NO.: G 1066-02

BORING TYPE: Dry Auger

DATE

7/25/02

SURFACE ELEVATION

310.0

MOISTURE CONTENT (%)	ATTERBERG LIMITS(%)			MINUS #200 SIEVE (%)	OTHER TESTS PERFORMED (Page Ref #)
	LIQUID LIMIT	PLASTIC LIMIT	PLASTICITY INDEX		
29	81	24	57	91	+40 Sieve =2%
20	57	20	37	78	+40 Sieve =10%
23	58	20	38	90	+40 Sieve =2%
29	62	20	42	95	+40 Sieve =1%

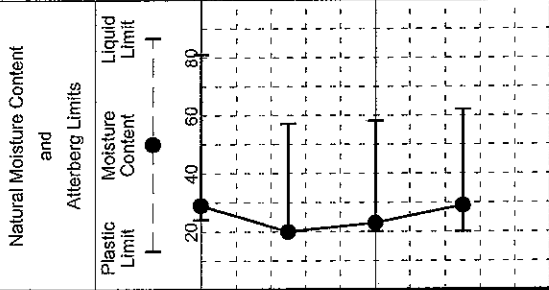

DRY DENSITY (pcf)	COMPRESSIONIVE STRENGTH (tsf)	FAILURE STRAIN (%)	CONFINING PRESSURE (1)

FIELD STRENGTH DATA	BLOW COUNT	Qu (tsf)	PPR (tsf)	Torvane (tsf)
	20	2.0	3.0	4.0
	40	2.0	3.0	4.0
	60	2.0	3.0	4.0
	80	2.0	3.0	4.0

Notes:

Key to Abbreviations:

- N - SPT Data (Blows/Ft)
- P - Pocket Penetrometer (tsf)
- T - Torvane (tsf)
- L - Lab Vane Shear (tsf)

Water Level Est.: ∇ Measured: ∇ Perched: ∇
 Water Observations: Seepage @ 17' while drilling. Dry and open upon completion.

LOG OF BORING C-3

DATE: 7/25/02

SURFACE ELEVATION: 313.0

PROJECT: Lake Eastex
Jacksonville, Texas

BORING TYPE: Dry Auger

PROJECT NO.: G 1066-02

ETTL ENGINEERS & CONSULTANTS

MAIN OFFICE
1717 East Erwin
Tyler, Texas 75702
(903) 595-4421

DEPTH (#)	SAMPLES	USC	WATER LEVEL	FIELD STRENGTH	DATA	BLOW COUNT	DRY DENSITY (pcf)	COMPRESSION STRENGTH (tsf)	FAILURE STRAIN (%)	CONFINING PRESSURE (1)	Atterberg Limits		MOISTURE CONTENT (%)	ATTERBERG LIMITS (%)	MINUS #200 SIEVE (%)	OTHER TESTS PERFORMED (Page Ref #)
											Plastic Limit	Liquid Limit				
0																
10		CH														
20		CL														

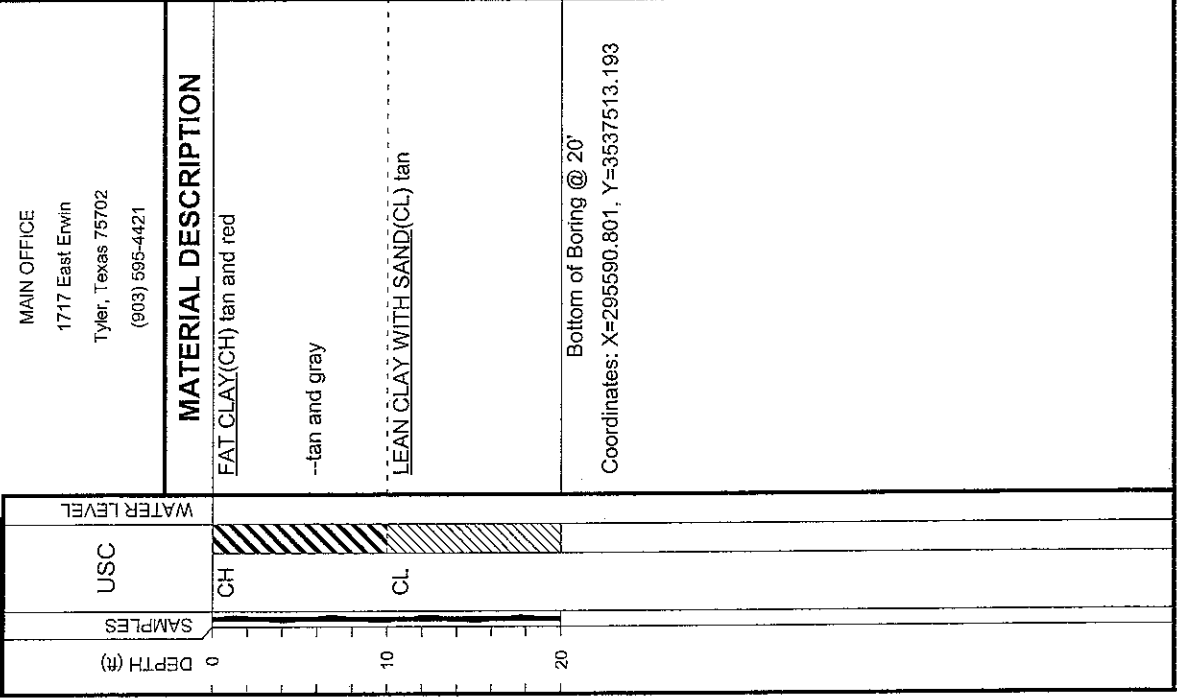

Water Level

Water Observations:

Est: Measured: Perched:

Dry and open upon completion.

Key to Abbreviations:
N - SPT Data (Blows/Ft)
P - Pocket Penetrometer (tsf)
T - Torvane (tsf)
L - Lab Vane Shear (tsf)

Notes:



**ETTL
ENGINEERS &
CONSULTANTS**

MAIN OFFICE
1717 East Erwin
Tyler, Texas 75702
(903) 595-4421

LOG OF BORING C-4

PROJECT: Lake Eastex
Jacksonville, Texas
PROJECT NO.: G 1066-02

BORING TYPE: Dry Auger

DATE
7/26/02

SURFACE ELEVATION
272.0

DEPTH (#)	SAMPLES	USC	WATER LEVEL	FIELD STRENGTH DATA	BLOW COUNT	DRY DENSITY (pcf)	COMPRESSIVE STRENGTH (tsf)	FAILURE STRAIN (%)	CONFINING PRESSURE (1)	Natural Moisture Content and Atterberg Limits		MOISTURE CONTENT (%)	ATTERBERG LIMITS (%)			MINUS #200 SIEVE (%)	OTHER TESTS PERFORMED (Page Ref #)
										Plastic Limit	Liquid Limit		PL	PL	PL		
0												12					
10	SM											19	31	16	15	53	+40 Sieve = 1%
10	CL											23				23	+40 Sieve = 1%
20	SM											22				12	+40 Sieve = 39%

MATERIAL DESCRIPTION

SILTY SAND(SM) tan
 SANDY LEAN CLAY(CL) tan, red, and gray
 SILTY SAND(SM) tan
 SILTY SANDY(SM) red; with iron oxide cemented sandstone gravel

Bottom of Boring @ 20'
 Coordinates: X=297162.164, Y=3537341.244

Water Level Est: Measured: Perched:
 Water Observations: Seepage @ 11' while drilling. Water level @ 7' and caved to 7' upon completion.
 Key to Abbreviations:
 N - SPT Data (Blows/Ft)
 P - Pocket Penetrometer (tsf)
 T - Torvane (tsf)
 L - Lab Vane Shear (tsf)

Notes:



**ETTL
ENGINEERS &
CONSULTANTS**

MAIN OFFICE
1717 East Erwin
Tyler, Texas 75702
(903) 595-4421

MATERIAL DESCRIPTION

SILTY SAND(SM) gray and tan

--gray

--tan

SANDY SILT(ML) tan and gray

Bottom of Boring @ 20'

Coordinates: X=297130.847, Y=3538885.191

WATER LEVEL

USC

SAMPLES

DEPTH (ft)

SM

ML

0

10

20

LOG OF BORING S-2

PROJECT: Lake Eastex
Jacksonville, Texas
PROJECT NO.: G 1066-02

BORING TYPE: Dry Auger

DATE

7/26/02

SURFACE ELEVATION

287.0

FIELD STRENGTH DATA	BLOW COUNT ● 20 40 60 80 ▲ Qu (tsf) ▲ 1.0 2.0 3.0 4.0 ■ PPR (tsf) ■ 1.0 2.0 3.0 4.0 ◆ Torvane (tsf) ◆ 1.0 2.0 3.0 4.0	DRY DENSITY (pcf)	COMPRESSIVE STRENGTH (tsf)	FAILURE STRAIN (%)	CONFINING PRESSURE (1)	Natural Moisture Content and Atterberg Limits		MOISTURE CONTENT (%)	OTHER TESTS PERFORMED (Page Ref #)
						Plastic Limit	Moisture Content		
						20	23	16	+40 Sieve =2%
								13	+40 Sieve =1%
								14	+40 Sieve =1%
								51	+40 Sieve =1%

ATTERBERG
LIMITS(%)

LIQUID LIMIT

PLASTIC LIMIT

PLASTICITY INDEX

PI

PI

Key to Abbreviations:

N - SPT Data (Blows/Ft)

P - Pocket Penetrometer (tsf)

T - Torvane (tsf)

L - Lab Vane Shear (tsf)

Notes:

Estl: Measured: Perched:

Water level @ 3' and open upon

Water Level
Water Observations:
completion.



**ETTL
ENGINEERS &
CONSULTANTS**

MAIN OFFICE
1717 East Erwin
Tyler, Texas 75702
(903) 595-4421

MATERIAL DESCRIPTION

SILTY SAND(SM) tan

Bottom of Boring @ 20'

DEPTH (ft)
0
10
20

SAMPLES

USC

WATER LEVEL

LOG OF BORING S-3

PROJECT: Lake Eastex
Jacksonville, Texas
PROJECT NO.: G 1066-02

BORING TYPE: Dry Auger

DATE

7/26/02

SURFACE ELEVATION

283.0

FIELD STRENGTH DATA	BLOW COUNT ● 20 40 60 80 ▲ Qu (tsf) ▲ 1.0 2.0 3.0 4.0 ■ PPR (tsf) ■ 1.0 2.0 3.0 4.0 ◆ Torvane (tsf) ◆ 1.0 2.0 3.0 4.0	DRY DENSITY (pcf)	COMPRESSIVE STRENGTH (tsf)	FAILURE STRAIN (%)	CONFINING PRESSURE (1)	Natural Moisture Content and Atterberg Limits			MOISTURE CONTENT (%)	MINUS #200 SIEVE (%)	OTHER TESTS PERFORMED (Page Ref #)
						Plastic Limit	Moisture Content	Liquid Limit			
									18	+40 Sieve =1%	
									16	+40 Sieve =0%	
									17	+40 Sieve =1%	
									17	+40 Sieve =7%	

Notes:

Key to Abbreviations:

- N - SPT Data (Blows/Ft)
- P - Pocket Penetrometer (tsf)
- T - Torvane (tsf)
- L - Lab Vane Shear (tsf)

Est: Measured: Perched:

Water level @ 13' and open upon

Water Level
Water Observations:
completion.



**EITL
ENGINEERS &
CONSULTANTS**

MAIN OFFICE
1717 East Erwin
Tyler, Texas 75702
(903) 595-4421

USC
SAMPLES
DEPTH (ft)

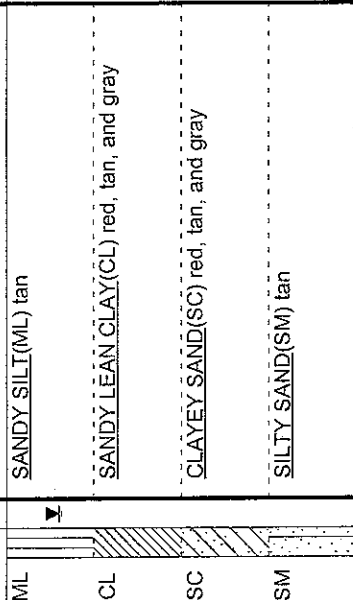

MATERIAL DESCRIPTION

SANDY SILT(ML) tan
SANDY LEAN CLAY(CL) red, tan, and gray
CLAYEY SAND(SC) red, tan, and gray
SILTY SAND(SM) tan

Bottom of Boring @ 20'

LOG OF BORING S-4

PROJECT: Lake Eastex
Jacksonville, Texas
PROJECT NO.: G 1066-02

BORING TYPE: Dry Auger

FIELD STRENGTH DATA	
● BLOW COUNT	20 40 60 80
▲ Qu (tsf)	1.0 2.0 3.0 4.0
■ PPR (tsf)	1.0 2.0 3.0 4.0
◆ Torvane (tsf)	1.0 2.0 3.0 4.0

DRY DENSITY (pcf)	
COMPRESSIVE STRENGTH (tsf)	
FAILURE STRAIN (%)	
CONFINING PRESSURE (1)	

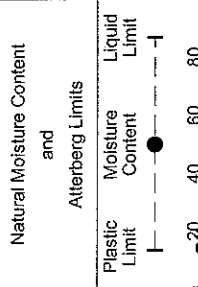

MOISTURE CONTENT (%)	14	19	18	31
LL	20	28	28	
PL	18	15	16	
PI	2	13	12	

MINUS #200 SIEVE (%)	66	57	40	29
----------------------	----	----	----	----

OTHER TESTS PERFORMED (Page Ref #)	+40 Sieve =2% +40 Sieve =6% +40 Sieve =32% +40 Sieve =23%
------------------------------------	--

DATE 7/25/02

SURFACE ELEVATION 283.0

Key to Abbreviations:
N - SPT Data (Blows/Ft)
P - Pocket Penetrometer (tsf)
T - Torvane (tsf)
L - Lab Vane Shear (tsf)

Water Level Est: Measured: Perched:
Water Observations: Seepage @ 1' while drilling. Water level @ 3' and open upon completion.

Notes:

APPENDIX C
LABORATORY TEST RESULTS

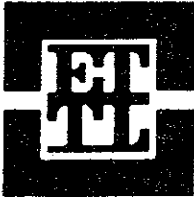

ETTL ENGINEERS & CONSULTANTS INC.

GEOTECHNICAL • MATERIALS • ENVIRONMENTAL

HOME OFFICE:

1717 East Erwin Street
Tyler, Texas 75702-6398
Office: (903) 595-4421
Lab: (903) 595-6402
Fax: (903) 595-6113

TEXARKANA:

210 Beech Street
Texarkana, Arkansas 71854
Office: (870) 772-0013
Fax: (870) 216-2413

LONGVIEW:

707 West Cotton Street
Longview, Texas 75604-5505
Office: (903) 758-0402
Fax: (903) 758-8245

Dispersive Potential of Soil (as used by U.S. Agency SCS)

Project:	Lake Eastex, Jacksonville, Texas	Job No	G 1066 - 02
Client:	Freese & Nichols, Fort Worth, Texas	Sample No	See List Below
Contractor:	N/A		
Material Origin:	On Site See List Below	Date Sampled:	07/26/02
Sampled by:	ETTL Drill Crew	Sampling info provided by:	ETTL Drill Crew
Material location:	See List Below		
Material description:	See List Below	Report No:	
Boring No	See List Below	Depth:	See List Below
Storage environment:	Bag Sample		
Date of testing:	08/01/02	Technician	Todd Sliger & HW

Specimen:

Sample #	Soil Description	15x15x15mm soil cube after submerging in water	Moister content %	Water temp "C"	Crumb test reaction after 2 min 15 min 1 and 24 hours			
					No Reaction	Slight React.	Moderate R	Strong React
C - 1 5' - 10'	Tan & Red Sandy Fat Clay	within 24 hours cube was mostly fallen apart	21.6%	24.0	2 min, 15 min 1 hour, 24 hrs			
C - 1 10' - 15'	Tan, Red & Gray Fat Clay	within 24 hours cube was mostly fallen apart	27.2%	24.5	2 min, 15 min 1 hour, 24 hrs			
C - 1 15' - 20'	Tan & Gray Lean Clay	within 24 hours cube was mostly fallen apart	23.7%	24.0	2 min	15 min	1 hour, 24 hrs	
C - 2 0' - 5'	Tan & Red Fat Clay	within 24 hours cube was partial fallen apart	28.6%	24.1	2 min, 15 min 1 hour, 24 hrs			
C - 2 5' - 10'	Tan & Red Fat Clay w/ Sa	within 24 hours cube was partial fallen apart	19.9%	24.1	2 min, 15 min 1 hour, 24 hrs			
C - 2 10' - 15'	Red & Gray Fat Clay	within 24 hours cube was partial fallen apart	23.0%	24.1	2 min, 15 min 1 hour, 24 hrs			
C - 2 15' - 20'	Gray & Tan Fat Clay	within 24 hours cube was partial fallen apart	28.9%	24.1	2 min	15 min	1 hour, 24 hrs	
C - 3 0' - 5'	Tan & Red Fat Clay	within 24 hours cube was partial fallen apart	18.6%	24.0	2 min, 15 min 1 hour, 24 hrs			
C - 3 5' - 10'	Tan & Gray Fat Clay w/ Sa	within 24 hours cube was mostly fallen apart	17.7%	24.1	2 mi, 15 min	1 hour, 24 hrs		
C - 3 10' - 15'	Tan Lean Clay w/Sa	within 24 hours cube was total fallen apart	18.6%	24.0	2 min	15 min	1 hour, 24 hrs	
C - 3 15' - 20'	Tan Lean Clay w/Sa	within 24 hours cube was total fallen apart	19.4%	24.0	2 min	15 min	1 hour, 24 hrs	
C - 4 5' - 10'	Tan, Red & Gray Sa Lean Clay	within 24 hours cube was mostly fallen apart	19.0%	24.0	2 min, 15 min 1 hour, 24 hrs			



ETTL ENGINEERS & CONSULTANTS INC.

GEOTECHNICAL • MATERIALS • ENVIRONMENTAL

HOME OFFICE:

1717 East Erwin Street
Tyler, Texas 75702-6398
Office: (903) 595-4421
Lab: (903) 595-6402
Fax: (903) 595-6113

TEXARKANA:

210 Beech Street
Texarkana, Arkansas 71854
Office: (870) 772-0013
Fax: (870) 216-2413

LONGVIEW:

707 West Cotton Street
Longview, Texas 75604-5505
Office: (903) 758-0402
Fax: (903) 758-8245

Dispersive Potential of Soil (as used by U.S. Agency SCS)

Project:	<u>Lake Eastex, Jacksonville, Texas</u>	Job No.	<u>G 1066</u>
Client:	<u>Freese & Nichols, Fort Worth, Texas</u>	Sample No.	<u>N/A</u>
Contractor:	<u>N/A</u>		
Material Origin:	<u>On Site</u>	Date Sampled:	<u>07/24/02</u>
Sampled by:	<u>ETTL Drill Crew</u>	Sampling info. provided by:	<u>ETTL Drill Crew</u>
Material location:	<u>See List Below</u>		
Material description:	<u>See List Below</u>	Report No:	_____
Boring No.	<u>B 106</u>	Depth:	<u>See List Below</u>
Storage environment:	<u>Jar</u>		
Date of testing:	<u>07/31/02</u>	Technician	<u>H. Walka</u>

Specimen:

Sample #	Soil Description	15x15x15mm soil cube after submerging in water	Moister content %	Water temp "C"	Crumb test reaction after 2 min 15 min 1 and 24 hours			
					No Reaction	Slight React.	Moderate R	Strong React
B 106 13' - 15'	Red & Tan Clay	within 24 hours cube was partial fallen apart	20.9%	24.1	2 min, 15 min 1 hour, 24 hrs			
B 106 18' - 20'	Tan & Brown Clay	within 2 minutes cube was partial fallen apart	30.3%	24.3	2 min, 15 min 1 hour, 24 hrs			
B 106 33' - 35'	Gray & Tan Clay	within 2 minutes cube was partial fallen apart	29.3%	24.4	2 min, 15 min 1 hour, 24 hrs			

APPENDIX 6 – SHPO CORRESPONDENCE



TEXAS HISTORICAL COMMISSION

The State Agency for Historic Preservation

RICK PERRY, GOVERNOR

JOHN L. NAU, III, CHAIRMAN

F LAWRENCE OAKS, EXECUTIVE DIRECTOR

September 26, 2001

Steven P. Watters
Discipline Leader
Environmental Permitting
Freese and Nichols, Inc.
4055 International Plaza
Fort Worth, TX 76109-4895

Re: Proposed Lake Eastex Regional Water Supply Pre-application Meeting
(COE-FWD)

Attention: Jessica Napier

Dear Mr. Watters:

Thank you for the invitation to attend the meeting referenced above. This letter serves as comment on the project from the State Historic Preservation Officer, the Executive Director of the Texas Historical Commission. As the state agency responsible for administering the Antiquities Code of Texas, these comments also provide recommendations on compliance with state antiquities laws and regulations.

Bill Martin of my staff attended a similar meeting for Lake Eastex in March of 1992. At that meeting he explained our position on the level of archeological and historical studies that would be needed for the development of Lake Eastex. Our position remains essentially unchanged, except where federal regulations have changed since 1992, requiring increased consultation with Native American tribes and the public. The following studies will be needed to comply with Section 106 of the National Historic Preservation Act and the Antiquities Code of Texas.

Geomorphology

A person with demonstrated expertise in interpreting the landforms and geomorphic processes peculiar to Northeast Texas, particularly along the Angelina River and its tributaries, should undertake a study of the geomorphic history of the basin. This study should focus on the reconstruction of the depositional history of the valley in order to identify the potential locations of buried sites and their approximate ages. Sufficient backhoe/tracker tests will have to be dug to examine and describe soil profiles and obtain samples for radiocarbon dating so that marker paleosols can be identified and targeted for archeological investigation. Because individual geomorphologists often have divergent opinions about the formation of landforms, we recommend that the results of the study be sent out for peer review by other qualified geomorphologists. This should serve to generate discussion and develop the best approach for the archeological survey.

Archival Research

Archival research should focus on the examination of primary sources, rather than studying secondary sources. The information contained at the Barker Texas History Center at the University of Texas at Austin, the maps and surveyor's field notes stored at the General Land Office in Austin, and the State Archives in Austin all should be searched for early information on historic settlement and the locations of historic period Indian villages. County records should also be examined. This work should be performed by a trained historian/archivist who has experience using these kinds of documents. The archival information can help locate early historic sites and can help interpret them once they are found and studied.

Archeological Survey

Professional archeologists have never surveyed the project area. We recommend that the project area be surveyed with consideration given to the recommendations of the geomorphologist, utilizing methods appropriate for finding sites on the different kinds of landforms encountered (e.g., shovel tests on terraces, backhoe trenches on floodplains). The survey should be performed by an archeologist meeting the professional qualifications listed in the *Secretary of the Interior's Standards and Guidelines* and the Chapter 26 Rules of Practice and Procedure for the Antiquities Code of Texas.

Avocational Collections

An important aspect of the survey phase work should be the documentation of artifact collections from the project area vicinity. This will help familiarize the surveyors with the type of sites and artifacts that may be present, and also will provide data gained from repeated visits to the same sites. This level of information is normally unavailable to professional archeologists conducting archeological surveys, who may only have an opportunity to spend a few hours on any given site. An archeologist experienced in Northeast Texas archeology should make an effort to contact all private citizens with collections of artifacts from sites in close proximity to the projects area. Interviews should be conducted to obtain as much information as possible about the sites where the artifacts were found. Then, the collections should be documented photographically, with notes linked to each photograph number that identify and describe the artifacts present in each frame.

Testing and Data Recovery

As the project progresses, we anticipate that there will be a need for testing to determine the National Register eligibility of sites located during the survey. This work would follow from a research design that takes into account the historic contexts presented in the State Plan for Northeast Texas (currently in draft form). Those sites that are determined eligible for inclusion on the National Register should be avoided and preserved if at all possible. Those sites that cannot be avoided will need to be mitigated through data recovery, which will probably require extensive excavations.

Because this project falls under the Antiquities Code of Texas, this agency must issue a permit prior to initiation of any studies. When seeking bids, please be sure to ask if the principal investigator is eligible to be issued a permit. We look forward to further consultation with your office and hope to maintain a partnership that will foster effective historic preservation. Thank you for your cooperation in this federal review process, and for your efforts to preserve the irreplaceable heritage of Texas. **If you have any questions concerning our review or if we can be of further assistance, please contact Bill Martin at 512/463-5867.**

Sincerely,



for
F. Lawrence Oaks, State Historic Preservation Officer

FLO/wam

cc: Mr. Robert Scott, Corps of Engineers, Fort Worth District

APPENDIX 7 –

TWDB COMMENTS ON DRAFT REPORT AND ANRA RESPONSES



TEXAS WATER DEVELOPMENT BOARD



E. G. Rod Pittman, *Chairman*
Wales H. Madden, Jr., *Member*
Thomas Weir Labatt III, *Member*

J Kevin Ward
Executive Administrator

Jack Hunt, *Vice Chairman*
William W Meadows, *Member*
Dario Vidal Guerra, Jr., *Member*

April 29, 2003

Mr Kenneth Reneau
General Manager
Angelina & Neches River Authority
P. O. Box 387
Lufkin, Texas 75901

Re: Regional Water Facility Planning Grant Contract Between the Angelina Neches River Authority (ANRA) and the Texas Water Development Board (Board), TWDB Contract No 2001-483-385, Draft Final Report Comments

Dear Mr. Reneau:

Staff members of the Texas Water Development Board have completed a review of the draft report under TWDB Contract No. 2001-483-385. As stated in the above referenced contract, ANRA must consider incorporating comments from the EXECUTIVE ADMINISTRATOR shown in Attachment 1 and other commentors on the draft final report into a final report. ANRA must include a copy of the EXECUTIVE ADMINISTRATOR's comments in the final report.

The Board looks forward to receiving one (1) unbound camera-ready original, nine (9) bound double-sided copies, and one (1) electronic copy of the Final Report in MS Word format on this planning project.

Please contact Mr. Kris Martinez, the Board's designated Contract Manager, at (512) 936-2388 if you have any questions regarding this matter.

Sincerely,

William F. Mullican, III
Deputy Executive Administrator
Office of Planning

c: Steve Watters, Freese & Nichols, via fax (817) 735-7492
Kris Martinez, TWDB

Our Mission

Provide leadership, technical services and financial assistance to support planning, conservation, and responsible development of water for Texas.

PO Box 13231 • 1700 N. Congress Avenue • Austin, Texas 78711-3231

Telephone (512) 463-7847 • Fax (512) 475-2053

1-800-RELAYTX (for the hearing impaired)

URL Address: <http://www.twdb.state.tx.us>

E-Mail Address: info@twdb.state.tx.us

TNRIS - The Texas Information Gateway • www.tnris.state.tx.us

A Member of the Texas Geographic Information Council (TGIC)



ATTACHMENT 1

TEXAS WATER DEVELOPMENT BOARD

Review of the Draft Final Report entitled "Lake Eastex Planning Studies" Contract No. 2001-483-385

1. The report appears to be very comprehensive and adequately address all Statement of Work (SOW) items. Furthermore the report is organized in the same manner as the SOW, which greatly facilitated the review. The consultant is to be complimented for the excellent handling of references and the well-written and well-illustrated presentation of technical information.
2. This report provides updated construction estimates for the proposed reservoir project. All costs identified in the Opinion of Probable Construction Cost appear to be eligible for financing through the Texas Water Development Board. Reservoir construction projects are not eligible for the pre-design funding option; therefore, all approvals and permits for the project would have to be in place prior to a commitment by the Board.
3. Explain how the dam height and reservoir storage were determined.
4. There are several issues with Chapter 2 and Appendix 2:
 - a. In Section 2.1.4, the runoff entering Eastex is said to be equal to the sum of the spills from Tyler and the naturalized flow from incremental drainage area. This is correct only if (1) no other water rights in between Tyler and Eastex are senior to Eastex, or (2) they are senior to Eastex but will not use the naturalized flow prior to Eastex's capture. Explain which is true.
 - b. The study did not allow release from Eastex for any downstream water rights, claiming that "Sam Rayburn's water permit does not have priority calls on water" from the watershed where Eastex is located.
 - This language cannot be found in the Certificates of Adjudication #06-4411, 06-4411A, or 06-4411B.
 - In addition, the Eastex permit (#4228), in its Special Condition, indicates that Eastex must pass through inflow for downstream senior or superior rights if ordered to do so.
 - Please provide exact citation of language from Texas Commission on Environmental Quality (TCEQ) certificates that supports the assumption of Eastex's zero release for downstream water rights.
 - c. The minimal reservoir firm yield from this study is 65,830 acft (Table 2.1). This yield does not match the firm yield numbers calculated by TCEQ WAM. Explain how this yield is derived and why this new yield figure is more representative than the previous WAM derived figures.
 - d. The study did not use Neches WAM inflows for instream flow evaluation because "incorrect curve numbers were used in the Neches WAM at the reservoir site". Please explain in more detail why the curve numbers were considered to be incorrect.

5. Page 2-3. The first paragraph under Section 2.1.4 includes the sentence, "Although the runoff values calculated in the Neches River WAM are incorrect, the raw data presented in the (WAM) report are valid." No explanation is provided, and the reader must turn to Page 1 of Appendix 2 to learn the alleged inaccuracies of the Neches River WAM. The report should add one or more of the following:
 - a. In Section 2.1.4, refer to a more detailed explanation in Appendix 2. Expand the discussion of the Neches River WAM in Appendix 2 to describe why the runoff values are incorrect.
 - b. Explain the inaccuracies of the Neches River WAM, Section 2.1.4.
6. Chapter 3.0 – It isn't necessary to define RCW in the title, since it's defined in the first sentence.
7. Page 3-6. It would be helpful if dates were provided for the personal communications with Bill Rose and James Houser.
8. Explain what initial reservoir storage is used when estimating the peak discharges and peak reservoir stages (Table 6-4). For example, if the initial storage is assumed empty, 50% full, etc. Explain why this initial condition is used and how the assumption on initial condition will effect the estimates on peak discharges and peak stages.
9. Page 1 of Appendix 4, 7th Line from the bottom. Word should be opposed rather than apposed.

**ANRA Response to
Texas Water Development Board
Review of the Draft Final Report entitled
“Lake Eastex Planning Studies”
Contract No. 2001-483-385**

Item 1.

No action required.

Item 2.

No action required.

Item 3.

The reservoir storage was determined by the area capacity at the dam site. A yield study prepared in 1984 by Lockwood, Andrews and Newnam, Inc., determined the initial reservoir storage. The area and capacity characteristics of the Lake Eastex site were determined by digitizing the contours on USGS quadrangle maps of the reservoir site.

The dam height was determined based on TCEQ regulations for dams. In Texas, a large dam, or one with a storage of greater than 50,000 acre-feet, must be capable of passing 100 percent of the PMF event through the spillways without overtopping the dam. The PMF event was routed through the reservoir using HEC-1 and the spillways were sized using an iterative process as described on page 6-8 of the report. The top of the dam was set above the elevation for the PMF event with the spillway sizes selected.

Item 4.

Item 4a.

According to the Texas Commission on Environmental Quality electronic database for water rights, there are only two water rights between the Tyler Lakes and Lake Eastex. Both are for recreational use, and neither has any authorized diversion. There are no authorized diversions between the Tyler Lakes and Lake Eastex.

Item 4b.

The exact citation of language requested is from Special Condition 5.D. of Certificate of Adjudication 06-4411:

“5.D. Owner’s rights, under the priority date of November 12, 1963, authorized by this certificate of adjudication, shall be subordinate to any rights hereafter granted for storage and/or use of waters in and above the proposed Ponta Dam on the Angelina River and the proposed Weches Dam on the Neches River.”

Technical information located in Attachment A of this Appendix includes excerpts from the hydrology report prepared by TCEQ staff when the ANRA water right permit was issued. Note that:

- All of the water rights granted by Certificate of Adjudication #4411 as amended relating to Lake Sam Rayburn and Lake B.A. Steinhagen have a priority date of November 12, 1963, and are thus subject to this special condition.
- The proposed Ponta Dam is located on the Angelina River below the mouth of Mud Creek.
- The proposed and permitted Lake Eastex is upstream from the proposed Ponta Dam.
- Permit 4288 was granted after the permit underlying CA-4411 and allows storage and/or use of the waters above the proposed Ponta Dam on the Angelina River.
- Therefore, the rights granted under CA-4411 with a priority date of November 12, 1963 (which include the rights associated with Lake Sam Rayburn) are subordinate to the Lake Eastex water rights granted under Permit 4288.

Item 4c.

The derivation of the yields for various assumptions is described in the report. The specific yield of 65,830 acre-feet per year cited from Table 2.1 is based on:

- Inflows equal to spills from the Tyler Lakes plus naturalized flows for area between the Tyler Lakes and the proposed Lake Eastex. (The naturalized flows were based on flows between the Mud Creek near Tyler and Mud Creek near Jacksonville USGS gages multiplied by a drainage area ratio.)
- Impoundment of all inflows except bypasses.
- 100 years of estimated sedimentation.
- No return flows of wastewater upstream from the reservoir.
- Bypasses of reservoir inflows based on the consensus method.

Table 2.1 also shows the yields for other combinations of assumptions on return flows, reservoir sedimentation, and bypass requirements.

The new yield figures are more representative than the previous WAM derived figures due to two significant problems with the Neches WAM:

- The WAM incorrectly assumes that Lake Eastex would have to make releases of inflows in order to meet priority water rights associated with Lake Sam Rayburn and Lake B.A. Steinhagen. As explained above, this is incorrect because the water right for use from Lake Sam Rayburn and Lake B.A. Steinhagen states that the authorized use is subordinate to certain types of upstream water rights. Lake Eastex is among the types of water rights to which use from Lake Sam Rayburn and Lake B.A. Steinhagen is subordinate.

- The WAM uses an incorrect curve number for the watershed upstream from Lake Eastex and therefore significantly underestimates the inflow to the reservoir.

Item 4d.

The Neches WAM used SCS curve numbers, drainage area ratios, and average rainfall to estimate the runoff for ungaged areas on the basis of runoff for gaged areas. The SCS curve number is a dimensionless number between 0 and 100 that represents the effect of soil type and land use on runoff from a watershed. A curve number of 100 represents an impervious watershed, on which all rainfall turns into runoff. A curve number of 0 represents a totally permeable watershed, on which all rainfall infiltrates and none runs off. Curve numbers less than 0 or greater than 100 are not physically possible.

The SCS curve number for a given watershed is equal to the weighted average curve number for all parts of the watershed. In the Neches WAM, the 376.26 square mile watershed of the Mud Creek near Jacksonville USGS gage was assigned a curve number of 71. The 383.42 square mile Lake Eastex watershed was assigned a curve number of 67.

This information can be used to solve for the implied curve number in the 7.16 square mile watershed between the Jacksonville gage and the Lake Eastex dam:

<i>Lake Eastex Curve Number =</i>	<i>Jacksonville gage curve number x Jacksonville gage drainage area + Intervening area curve number x Intervening drainage area</i>
	<i>Jacksonville gage drainage area + Intervening drainage area</i>

Substituting known quantities:

$$67 = (71 \times 376.26 + \text{Intervening curve number} \times 7.16) / (376.26 + 7.16)$$

Or:

$$67 = 69.674 + \text{Intervening curve number} / 53.55$$

Solving:

$$\text{Intervening curve number} = -143.2$$

Since the curve number must be between 0 and 100, the negative value for the intervening curve number means that one or both of the curve numbers assigned in the WAM is in error.

Similarly, in the WAM the Mud Creek gage watershed was assigned an average annual rainfall of 47 inches, and the Lake Eastex gage was assigned an average annual rainfall of 44 inches. This requires an average rainfall of -113.6 inches for the 7.16 square mile intervening watershed. Again, one or both of the average annual rainfall values assigned in the WAM is in error.

These errors in curve number and rainfall values lead to an underestimate of the inflow to Lake Eastex for the WAM. The average annual naturalized flow for the Mud Creek near Jacksonville gage from the WAM is 202,637 acre-feet per year. The average annual naturalized flow for the Lake Eastex gage a few miles downstream and capturing inflow from 7.16 square miles of additional area is 179,914 acre-feet per year. This discrepancy is even greater under drought conditions. Since the WAM indicates that losses in the Neches Basin are not significant, this reduction in naturalized flow downstream is a result of the error in assumed watershed characteristics.

The explanation above seems unduly lengthy, specific, and technical to be added to the report. However, to address this item, we will add the following at the end of the first paragraph in Section 2.1.4:

“Appendix 2 includes a more detailed discussion of the problem with curve numbers in the Neches WAM.”

In addition, we will add the following at the end of the first bullet under Runoff in Appendix 2:

“(The curve numbers used in the Neches WAM require physically impossible conditions for the watershed between the Mud Creek near Jacksonville USGS gage and the dam site. The result of this error was that the naturalized inflows for Lake Eastex in the WAM were significantly less than the naturalized flows at the upstream gage site, which is not possible in a reach with no channel losses.)”

Item 6.

The definition of RCW has been removed from the title of Chapter 3.0.

Item 7.

The dates of personal communications with Bill Rose and James Houser have been added on page 3-6.

Item 8.

The reservoir routing was computed assuming the reservoir is initially at a normal pool elevation of 315 feet NGVD. If a lower starting water surface was assumed, the initial volume of the storm would be captured in the reservoir and it would result in a lower overall discharge and stage, which would result in underestimating the discharge capacity needed for the emergency spillway.

Item 9.

The word “apposed” has been replaced with the word “opposed” on page 1 of Appendix 4.

APPENDIX 7, ATTACHMENT A

Excerpts from ANRA water right permit hydrology report

Texas Water Commission
December 31, 1984
Page 2

The Preliminary Determination recognizes no water rights on the Angelina or Nechos Rivers downstream of Lake Sam Rayburn to Lake B. A. Steinhagen.

Permit No. 2124 (A-2298) authorizes the lower Neches Valley Authority (LNVA) to impound and regulate in Lake B. A. Steinhagen on the Neches River the hydroelectric power releases from Lake Sam Rayburn on the Angelina River and to release from Lake B. A. Steinhagen 820,000 acre-feet per year of the releases from Lake Sam Rayburn and the yield of Lake B. A. Steinhagen for subsequent downstream diversion from the Neches River and Pine Island Bayou for municipal, industrial and irrigation use. The Preliminary Determination recognizes the right to divert a reduced total of 759,700 acre-feet per year under this permit, but may be contested by the LNVA. The permit contains the following provision:

"7. . . . This permit shall be subordinate to any rights hereafter granted by the Commission for storage and/or use of waters in and above the proposed Ponta Dam on the Angelina River.

The Applicant's proposed reservoir on Mud Creek is upstream of the proposed Ponta Dam site on the Angelina River.

Water rights of record on the Neches River downstream of Lake B. A. Steinhagen to Sabine Lake include three Certified Filings, eight permits and three claims for a total of 1,266,785 acre-feet per year for municipal, industrial and irrigation use. The Preliminary Determination recognizes rights to divert a reduced total of 1,032,712 acre-feet per year under these water rights, but may be subject to several contests. The annual discharge at USGS Gage No. 08041000 Neches River at Evadale, located upstream of all of these water rights averaged 3,699,000 acre-feet during the period 1965 through out 1982.

cc: William G. Crolley, Read, Applications Unit, TDWR
David P. Cram, General Counsel Staff, TDWR

Texas Department of Water Resources
INTEROFFICE MEMORANDUM

TO: Texas Water Commission DATE: December 21, 1984

THRU: V. Dean Robbins, Assistant Director, Permits Division
Jerry Boyd, Chief, Water Use Section

FROM: Suzanne Schwartz, Assistant General Counsel, Water Rights
Hydrology Unit

SUBJECT: Angelina and Naches River Authority Application
Eastex Reservoir, Mud Creek, Naches River Basin
Cherokee County

Spillway Adequacy Analysis:

Staff's evaluation of the subject dam indicates the structure is adequate to pass a 72-hour duration Probable Maximum Flood without being overtopped. The dam is considered to be hydraulically sufficient as proposed.

Jacqueline S. Hardee

Anton E. Rozsypa

Texas Water Commission

Page 2

October 22, 1984

Surface Area : 10,000 acres.

Drainage Area : 391 square miles.

Diversion Facilities : From the perimeter of the reservoir at a maximum rate of 356.5 cfs (160,000 g.p.m.).

Fees: Paid

Remarks:

1. Applicant states if a permit is granted construction works will begin within two years and completed within five years from the date of issuance of a permit.
2. Applicants Engineer Lockwood, Andrews & Newman, Inc has prepared and provided an engineering report and engineering plans for the proposed project.
3. The application lists several entities which have requested water from the project.

Recommend the application be filed and set in public hearing.

Applications Unit:

Herman R. Settemeyer

William G. Crolley

URS/ry

Attachment: Map

cc: David Cram, General Counsel, TDWR
Hydrology Unit, Permits Division, TDWR